

CNTD®



Industrial Control Division

C5 Toggle Switch	B01-02
C6 Toggle Switch	B03-04
CK Miniature General Purpose Relay	B05-07
CSR Solid State Relay	B08-13
CFS Foot Switch	B14-15
CB Power Pushbutton Switch	B16-17
CMR Monolever Switch	B18-19
Warning Lamp	B20-25
Motor Siren	B26
Buzzer	B26
Warning Lamp Accessories	B26
CUK General Connection Terminal	B27-29
CBD Double-layer Plate Type Screw Crimping Terminal	B29
CUSLKG General Earthing Terminal	B30
CBC Cassette Assembly Terminal Block	B31
CBR Plate Type Screw Crimping Terminal Block	B32

B



Features

- 10A type and 15A type for selection
- Fixed type and auto-return type (both single-throw and double-throw) for selection
- Screw terminal, solder terminal and tab terminal for selection
- Water-proof cap for water-proof and oil-proof
- Mounting hole: ϕ 12mm

Model Number Structure

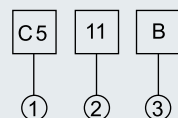

Items	Code	Description
① Type	CO	10A 250VAC Self-locking
	COR	10A 250VAC Spring return
	C5	15A 250VAC Self-locking
	C5R	15A 250VAC Spring return
② Contact	11	Single pole single throw ON-OFF
	12	Single pole double throw ON-ON
	13	Single pole double throw (central OFF)ON-OFF-ON
	131	Single pole double throw (central OFF single return)ON-OFF-ON
	21	Double pole single throw ON-OFF
	22	Double pole double throw ON-ON
	23	Double pole double throw (central OFF)ON-OFF-ON
	231	Double pole double throw (central OFF single return)ON-OFF-ON
③ Terminal	A	Tab terminal(#250)
	B	Screw terminal
	C	Solder terminal(#187)

Specifications

Contact resistance	15M Ω max. (initial)
Insulation resistance	100M Ω above under 500VDC
Dielectric strength	2000VAC, 50/60Hz For 1minute
Vibration	10-55Hz, 1.5mm double amplitude
Ambien temperature	Using: -20~+70 C (With no icing)
Humidity	85% RH max.
Electrical life	500,000 operations above

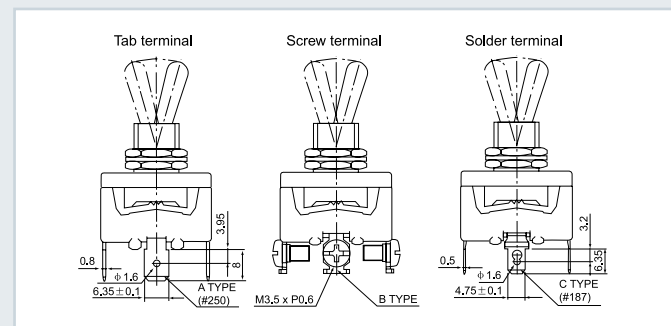

COW Rainproof cap (Tow)

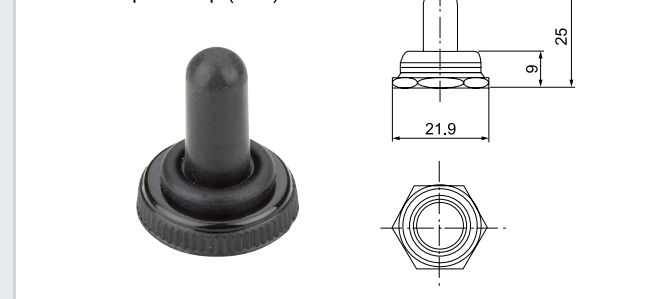

Ratings

Load	Type	AC Rating	DC Rating
Resistance Load	CO	10A 250V 15A 125V	0.4A 250V 0.8A 125V
	C5	15A 250V 20A 125V	0.5A 250V 0.9A 125V
Inductive Load	CO	10A 250V 15A 250V	0.2A 250V 0.4A 125V
	C5	15A 250V 20A 125V	0.3A 250V 0.5A 125V 15A
Lamp Load	CO	300W 100V 500W 200V	30V
	C5	400W 125V 800W 250V	-
Motor Load	CO	200W 125V 300W 250V	7A 30V
	C5	400W 125V(single phase)	-
	CO	550W 250V(three phase)	-
	C5	750W 250V(three phase)	

Appearance and Dimension



Features

- Current rating 15A 250VAC, 20A 125VAC
- Fixed type and auto-return type (both single-throw and double-throw) for selection
- Screw terminal, solder terminal and tab terminal for selection
- Protection structure IP67, water-proof cap for water-proof and oil-proof
- Mounting hole: ϕ 12mm

Model Number Structure

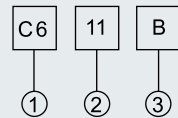

Items	Code	Description
① Type	C6	15A 250VAC 20A 125VAC Self-locking
	C6R	15A 250VAC 20A 125VAC Spring return
② Contact	11	Single pole single throw ON-OFF
	12	Single pole double throw ON-ON
	13	Single pole double throw (central OFF)ON-OFF-ON
	131	Single pole double throw (central OFF single return)ON-OFF-ON
	21	Double pole single throw ON-OFF
	22	Double pole double throw ON-ON
	231	Double pole double throw (central OFF single return)ON-OFF-ON
③ Terminal	A	Tab terminal(#250)
	B	Screw terminal
	C	Solder terminal(#187)

Specifications

Items	15M Ω max. (initial)
Contact resistance	100M Ω above under 500VDC
Insulation resistance	2000VAC, 50/60Hz For 1minute
Dielectric strength	10-55Hz, 1.5mm double amplitude
Vibration	Using: -20~+70 C (With no icing)
Ambien temperature	85% RH max.
Electrical life	500,000 operations above

Ratings

Load	Type	AC Rating	DC Rating
Resistance Load	C6	15A 250V 20A 125V	0.5A 250V 0.9A 125V
Inductive Load		15A 250V 20A 125V	0.3A 250V 0.5A 125V 15A
Lamp Load		400W 125V 800W 250V	-
Motor Load		400W 125V(single phase)	-
		750W 250V(three phase)	-

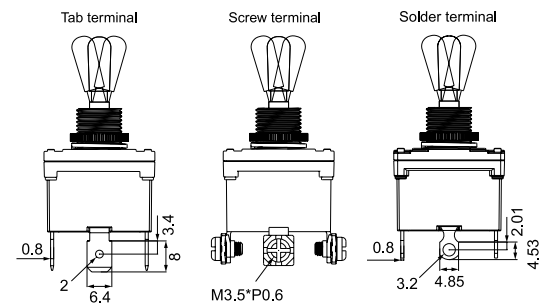

COW Rainproof cap (Tow)

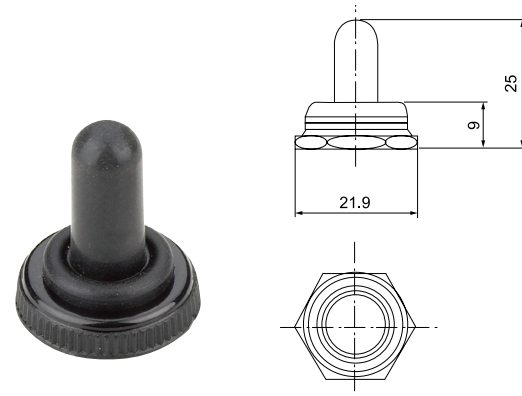

Appearance and Dimension

C611B
C6R11B

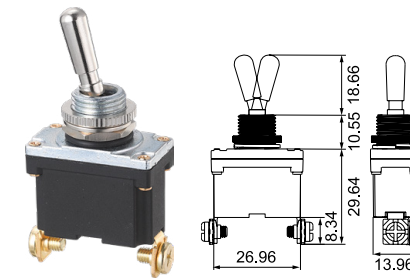

C612B
C6R12B

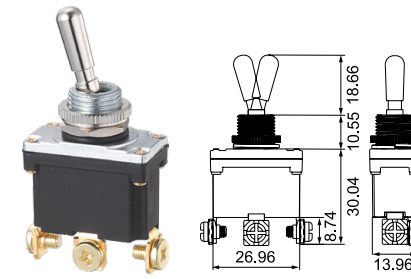

C613B
C6R13B

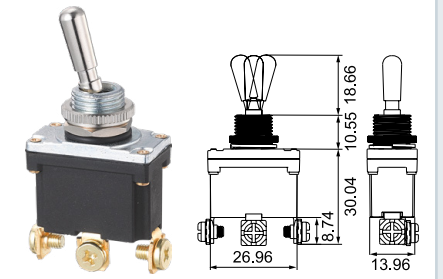

C621B
C6R21B

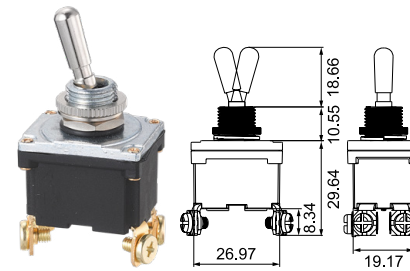

C622B
C6R22B

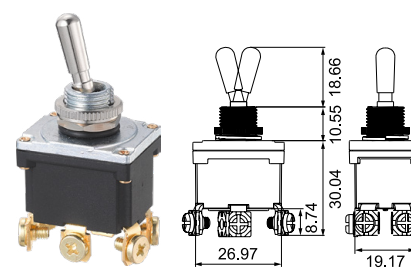

C623B
C6R23B

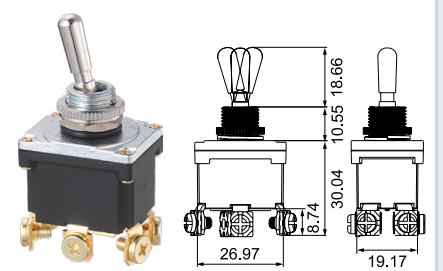

C611A
C6R11A

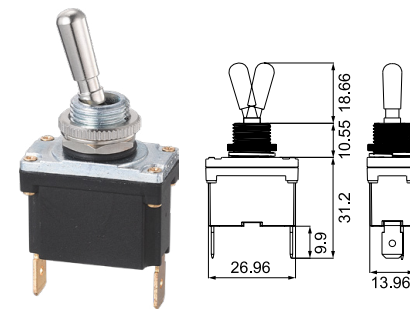

C612A
C6R12A

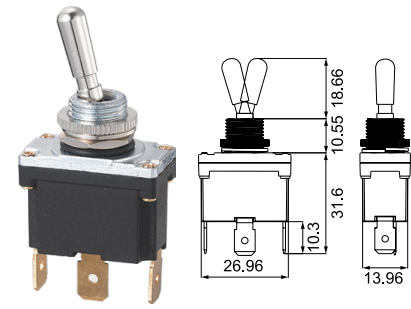

C613A
C6R13A

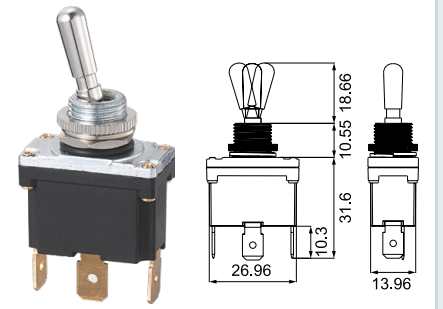

C621A
C6R21A

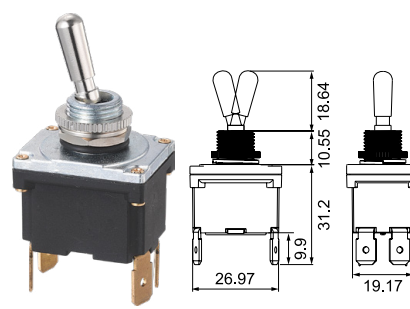

C622A
C6R22A

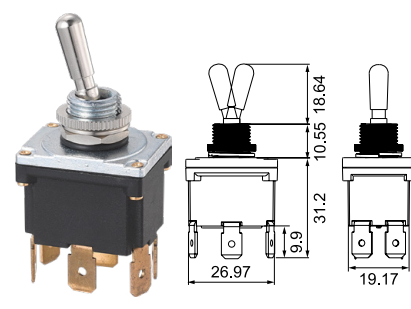

C623A
C6R23A

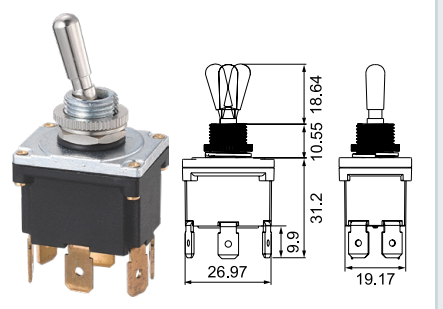

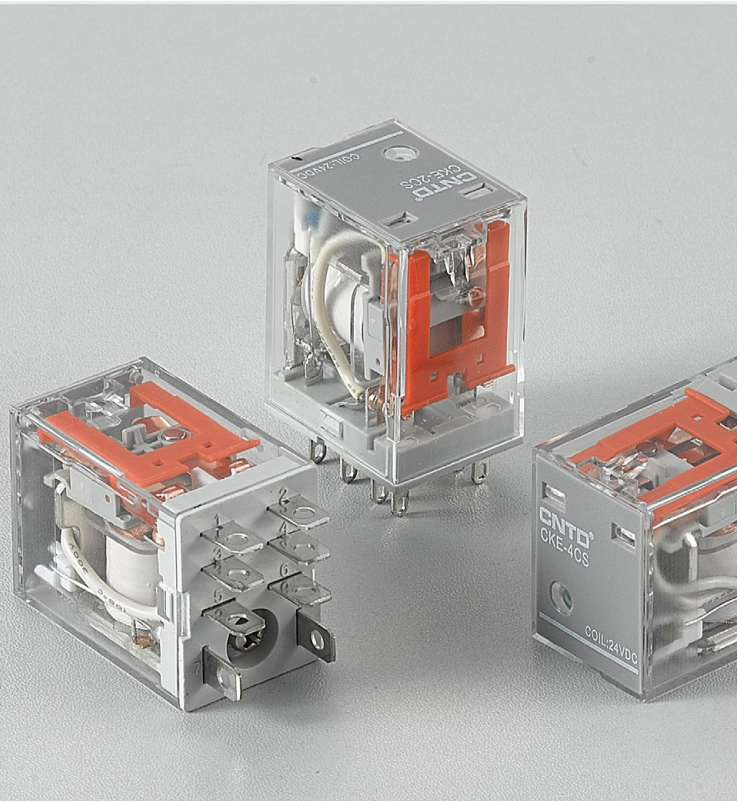

Features

- Small size and high sensitivity
- Large contact load 2C: 5A/10A, 4C: 3A
- Multiple specifications with two-way indicator
- With mechanical indicator window

Model Number Structure

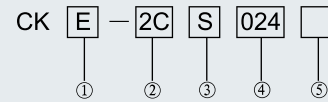

① Current form(Resistance)	E: Current load 3A, 5A L: Current load 10A
② Contact form	2C: 2 Set 4C: 4 Set
③ Mount options	S: Plug-in type; P: Welded type
④ Voltage	Reference coil specification code
⑤ Options	No, standard type; LT: LED+Test button LTD: LED+Test button+Diode

Specifications

Model	CKE-2CS	CKE-4CS	CKL-2CS		
Contact	Form	2C	4C	2C	
	Load(Resistance)	Resistance	5A/250VAC 30VDC	3A/250VAC 30VDC	10A/250VAC 30VDC
		Motor	1/6HP 240VAC	1/6HP 240VAC	1/3HP 240VAC
	Switching power (Resistance)	1750VA, 210W	750VA, 90W	2500VA, 300W	
	Initial contact (resistance)	50m	≤ 100m	≤ 100m	
	Material	Ag alloy	Ag alloy	Ag alloy	
	Electrical life(1s ON/ 1s OFF)	≥ 10 ⁵ (1800 Ops/h)	≥ 10 ⁵ (1800 Ops/h)	≥ 10 ⁵ (1800 Ops/h)	
Mechanical life(300 times / 1 min)	≥ 10 ⁷ (18000 Ops/h)	≥ 10 ⁷ (18000 Ops/h)	≥ 10 ⁷ (18000 Ops/h)		
Pick-up voltage (23℃)	DC: 75% (Rated voltage), AC: 80% (Rated voltage)	DC: 75% (Rated voltage), AC: 80% (Rated voltage)	DC: 75% (Rated voltage), AC: 80% (Rated voltage)		
Drop-out voltage (23℃)	DC: 10% (Rated voltage), AC: 30% (Rated voltage)	DC: 10% (Rated voltage), AC: 30% (Rated voltage)	DC: 10% (Rated voltage), AC: 30% (Rated voltage)		
Maximum voltage (23℃)	110% (Rated voltage)	110% (Rated voltage)	110% (Rated voltage)		
Insulation resistance	≥ 500M (500VDC)	≥ 500M (500VDC)	≥ 500M (500VDC)		
Coil operating power	DC(W)	Approx. 0.9	Approx. 0.9	Approx. 0.9	
	AC(VA)	Approx. 1.2	Approx. 1.2	Approx. 1.2	
Operate time (at nominal voltage)	≤ 20 ms	≤ 20 ms	≤ 20 ms		
Release time (at nominal voltage)	≤ 20 ms	≤ 20 ms	≤ 20 ms		
Initial breakdown voltage	Between open contacts	1000VAC/1min (leakage current 1mA)	1000VAC/1min (leakage current 1mA)	1000VAC/1min (leakage current 1mA)	
	Between poles	1000VAC/1min (leakage current 1mA)	1000VAC/1min (leakage current 1mA)	1500VAC/1min (leakage current 1mA)	
	Between contacts and coil	1500VAC/1min (leakage current 1mA)	1500VAC/1min (leakage current 1mA)	1500VAC/1min (leakage current 1mA)	
Ambient temperature	-25~+55℃	-25~+55℃	-25~+55℃		
Humidity	35%~85%RH	35%~85%RH	35%~85%RH		
Air pressure	86~106KPa	86~106KPa	86~106KPa		
Shock resistance	10G(sinusoidal half-wave pulse:11ms)	10G(sinusoidal half-wave pulse:11ms)	10G(sinusoidal half-wave pulse:11ms)		
Vibration resistance	10~55Hz double-amplitude:1.0mm	10~55Hz double-amplitude:1.0mm	10~55Hz double-amplitude:1.0mm		
Mounting	plug in	plug in	plug in		
Unit weight	35g	40g	40g		

Coil Specifications (23℃)

Model	CKE-2CS, CKE-4CS, CKL-2CS							
Voltage code(DC)	006	009	012 *	024 *	036	048 *	110	220
Nominal voltage V.DC	6	9	12	24	36	48	110	220
Coil resistance Ω	40	90	180	640	1500	2600	13000	42000
Voltage code(DC)	706	712	724 *	736	748 *	710	730 *	780
Nominal voltage V.AC	6	12	24	36	48	110	230	380
Coil resistance Ω	11.5	40	180	370	640	4430	16500	42000

Appearance and Dimension

CKE-2CS

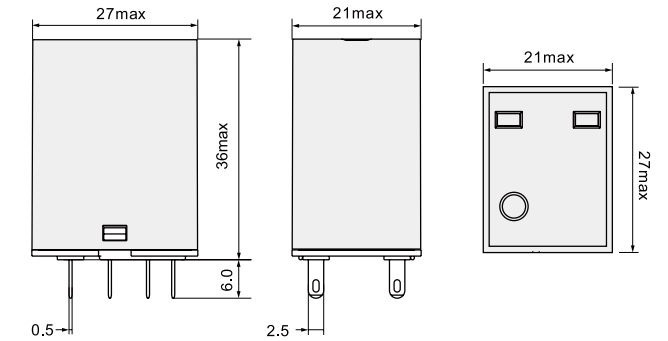

CKE-4CS

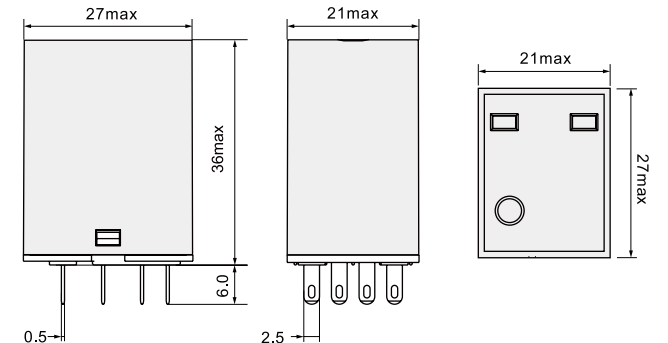

CKL-2CS

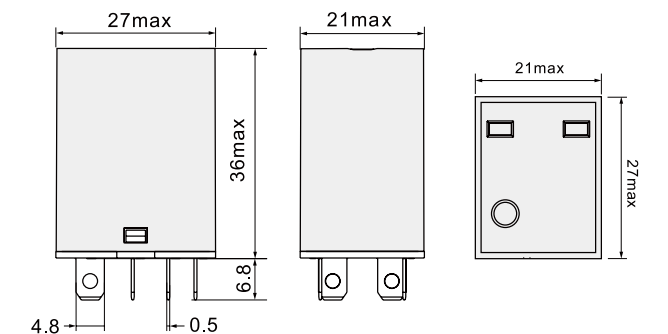
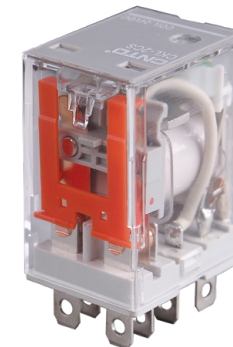



Wiring Diagram

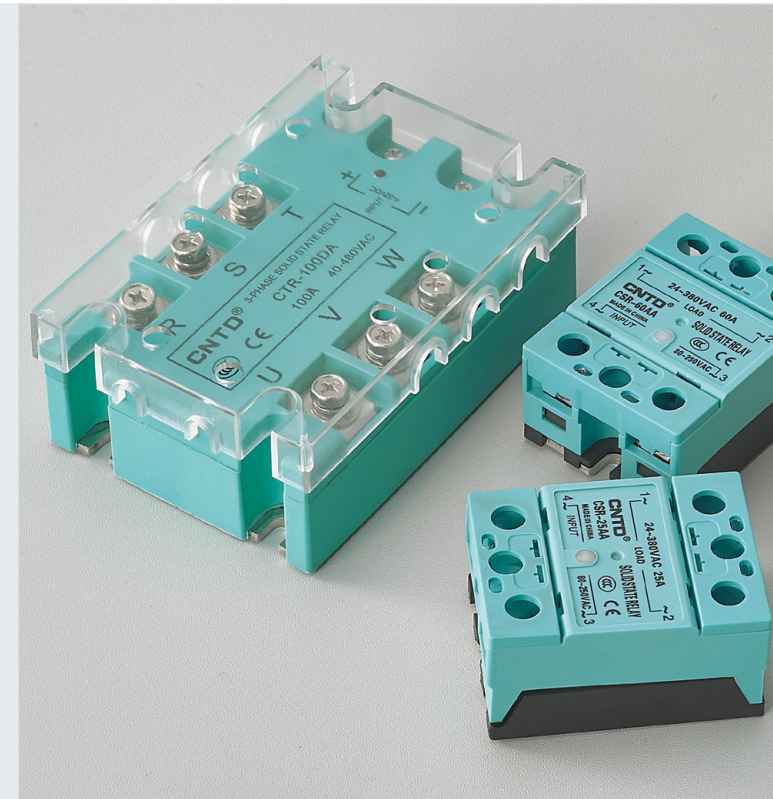
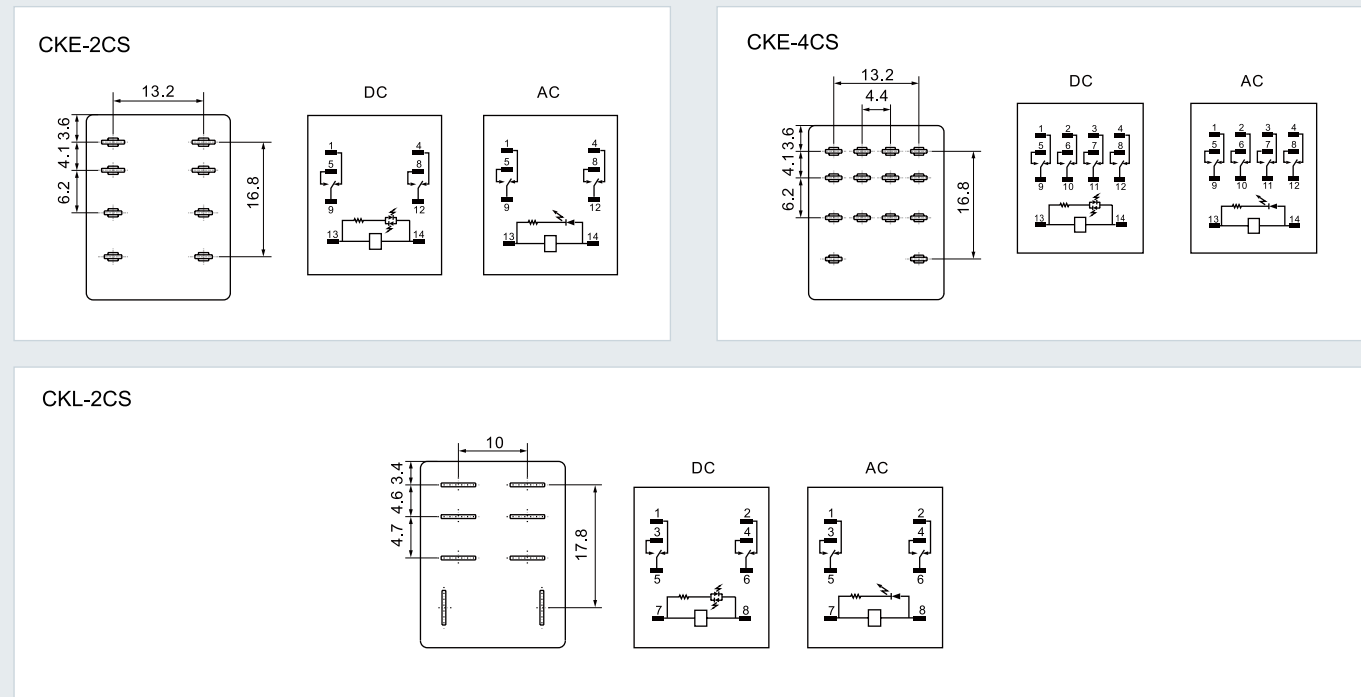

Overview

Solid State Relay(CSR) is industrial control appliances which use power semiconductor devices for main control part, compare with traditional magnetic contact industrial controllers, it is more high-powered, intelligent, digital, systematic and green development, according switch mode CSR have zero-cross and random type. When the input control signal, random type conduction immediately, zero cross type need load voltage turn to zero region just can conduction. Revocation of the control signal,all can cut off when less than maintenance current. zero cross type may cause the maximum half-cycle delay, but reduces the impact of the load and radiofrequency interference, is the ideal switching devices.Random type fast response,suitable for dimmer,thermostats resistive loads and some inductive load applications. When the CSR turn off, if in the phase current and voltage have different, will have a large rise rate (dv/dt) on the triac, such as dv/dt higher than Triac standtrd (300V/us), will result in delay shutdown even failure. use anti-parallel thyristor's CSR(powerful type) will be greatly improved at dv/dt(dv / dt is 500V/us). Therefore, in the field of capacitive load or inductive load, suggest the use powerful type CSR. CNTD's CSR are all powerful type. Solid-state voltage regulator consists of thyristor switching circuit, resistance-capacitance phase shifting circuit,lag circuit and over-voltage absorption circuit.The use of only one external potentiometer can be used to achieve AC power regulation.In many occasions can replace the heavy contact voltage lighting power supply,voltage,temperature,brightness, speed and other analog adjustment.

Relay Socket

<p>CYF08A-E</p> <table border="1"> <tr><td>Load current</td><td>7A</td></tr> <tr><td>Load voltage</td><td>300V</td></tr> <tr><td>Dielectric withstanding voltage</td><td>2500VAC/S</td></tr> </table>	Load current	7A	Load voltage	300V	Dielectric withstanding voltage	2500VAC/S	<p>CYF08A-K</p> <table border="1"> <tr><td>Load current</td><td>7A</td></tr> <tr><td>Load voltage</td><td>300V</td></tr> <tr><td>Dielectric withstanding voltage</td><td>2500VAC/S</td></tr> </table>	Load current	7A	Load voltage	300V	Dielectric withstanding voltage	2500VAC/S
Load current	7A												
Load voltage	300V												
Dielectric withstanding voltage	2500VAC/S												
Load current	7A												
Load voltage	300V												
Dielectric withstanding voltage	2500VAC/S												
<p>CYF14A-E</p> <table border="1"> <tr><td>Load current</td><td>5A</td></tr> <tr><td>Load voltage</td><td>300V</td></tr> <tr><td>Dielectric withstanding voltage</td><td>2500VAC/S</td></tr> </table>	Load current	5A	Load voltage	300V	Dielectric withstanding voltage	2500VAC/S	<p>CYF14A-K</p> <table border="1"> <tr><td>Load current</td><td>5A</td></tr> <tr><td>Load voltage</td><td>300V</td></tr> <tr><td>Dielectric withstanding voltage</td><td>2500VAC/S</td></tr> </table>	Load current	5A	Load voltage	300V	Dielectric withstanding voltage	2500VAC/S
Load current	5A												
Load voltage	300V												
Dielectric withstanding voltage	2500VAC/S												
Load current	5A												
Load voltage	300V												
Dielectric withstanding voltage	2500VAC/S												
<p>CTF08A-E</p> <table border="1"> <tr><td>Load current</td><td>10A</td></tr> <tr><td>Load voltage</td><td>300V</td></tr> <tr><td>Dielectric withstanding voltage</td><td>2500VAC/S</td></tr> </table>	Load current	10A	Load voltage	300V	Dielectric withstanding voltage	2500VAC/S	<p>CTF08A-K</p> <table border="1"> <tr><td>Load current</td><td>10A</td></tr> <tr><td>Load voltage</td><td>300V</td></tr> <tr><td>Dielectric withstanding voltage</td><td>2500VAC/S</td></tr> </table>	Load current	10A	Load voltage	300V	Dielectric withstanding voltage	2500VAC/S
Load current	10A												
Load voltage	300V												
Dielectric withstanding voltage	2500VAC/S												
Load current	10A												
Load voltage	300V												
Dielectric withstanding voltage	2500VAC/S												

Features

- Current:0.5A~400A
- Voltage:12V~680V
- General Install Size
- Vacuum Weld Technics
- Led indicator showing "ON" or "OFF"
- Protect Panel
- IEC standard
- Input & output type could chose DC/AC AC/AC DC/DC



Model Number Structure

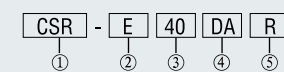

- 1 CSR=CNTD Single Phase Solid State Relay
CTR=CNTD Three Phase Solid State Relay
- 2 None= Improve Design Type(Light Green)
E=Standard Economic Type(Gray)
- 3 Rated Operation Current
- 4 Control & Load voltgge type
DA=DC(4-32V)AC(24-380V) AA=AC(80-250V)AC(24-380V)
DD=DC(4-32V)DC(12-240V) VA=Voltage regulator调压器(24 380VAC)
- 5 None=Zero Cross Trigger
R=Radom Switch

Applications

- AC DC switch & Temp control
- Automate Control
- CNC machinery
- Packaging machinery
- Textile machinery
- Glass machinery
- Plastic machinery

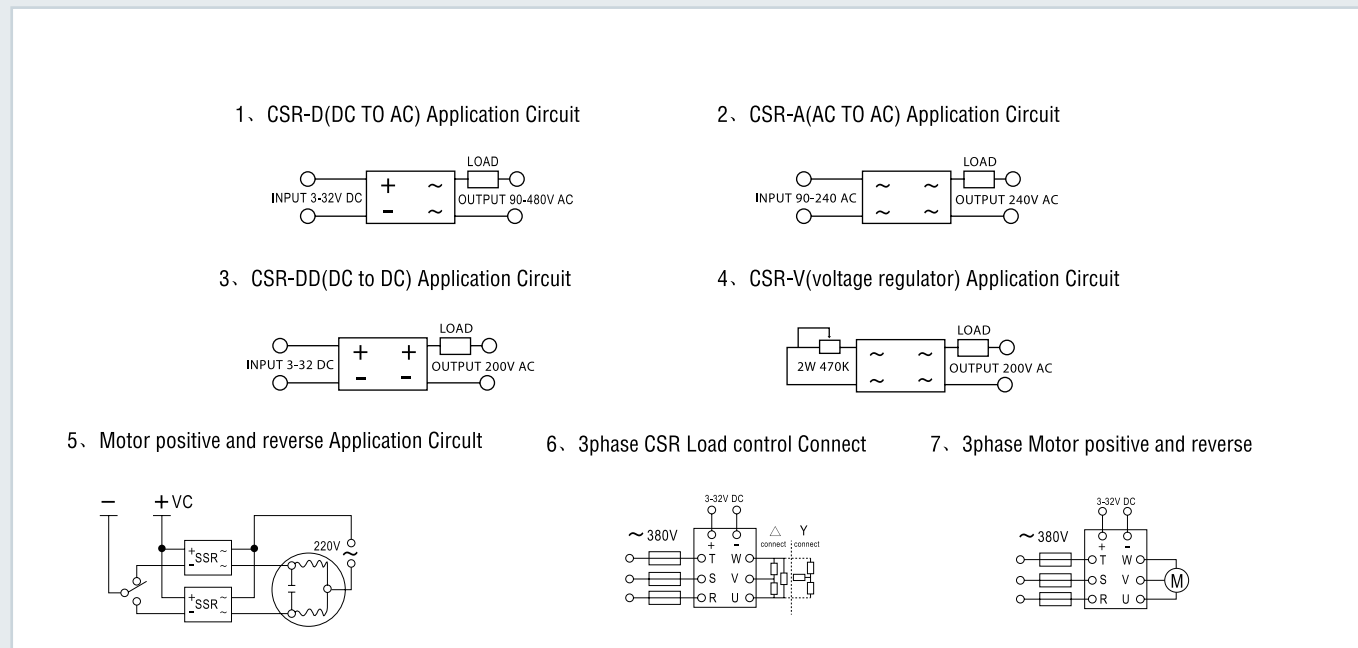

Specification	input parameter				output parameter				Safe Load			
	Control Voltage	Control Current	Start Current	Close Voltage	Operating Current	Operating Voltage	Insulate voltage	Protection Over Voltage	Protection Over Current	Resistive Load	Inductive Load	
CSR	DC/AC	4-32 V DC	<20mA	≥ 5mA	≤ 1.5V DC	10-100A	24-480 V AC	≥ 2500 VAC	RC MOV	Fast Fuse	60%	40%
	AC/AC	80-250 V AC	<30mA	≥ 5mA	≤ 10V AC	10-100A	24-480 V AC		RC MOV	Fast Fuse		
	Industry class	4-32 V DC	<20mA	≥ 5mA	≤ 1.5V DC	100-800A	24-480 V AC		Diode			
	DC/DC	3-32 V DC	<25mA	≥ 5mA	≤ 1.5V DC	10-40A	12-250 V DC					
CTR	4-32 V DC	<30mA	≥ 9mA	≤ 2.5V DC	10-120A	24-480 V AC	RC MOV	Fast Fuse				
Solid State Voltage Regulator	Potentiometer 500KΩ/1/4W				10-40A	10-250V AC		RC MOV	Fast Fuse			

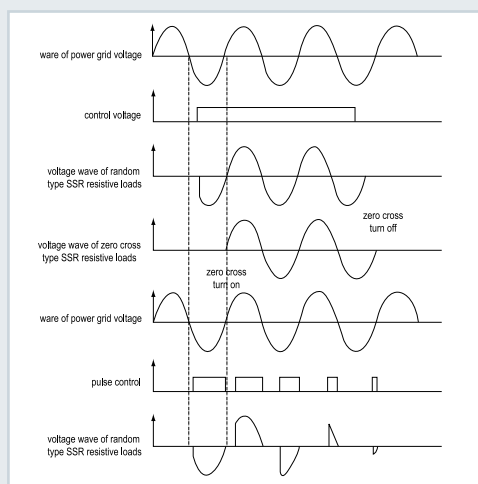

RC: Built-in resistance capacity absorption circuit.
MOV: External shunt metal oxide varistor.

Notes

1. Strictly prohibit for load short circuit. Can use fast fuse.
2. Ling time working current can't over 70% of the nominal value.
3. Heatsink temperature can't over 75 °C.
4. Use at inductive load area, adding varistor for protect is better.

Recommended value of load type (Room temperature)

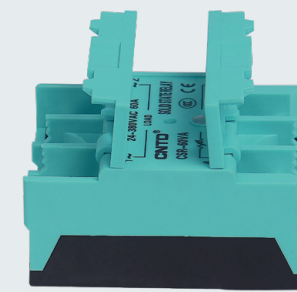

Patent design, using the coverprotection model, easy to operate

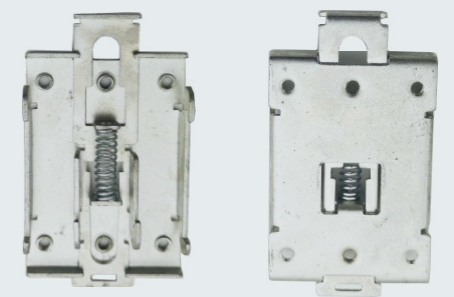

CSR-B01

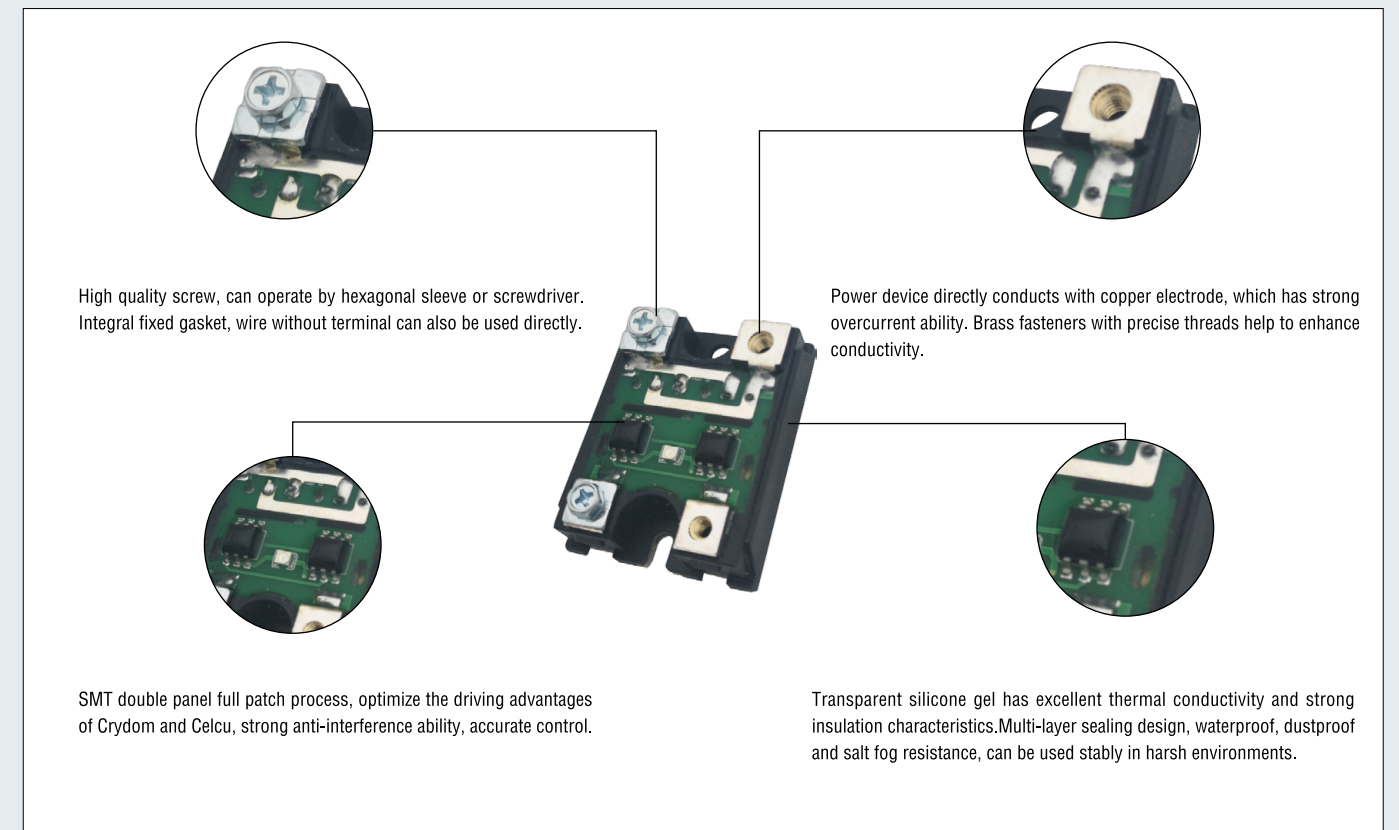

Specifications

Model	CSR-DA		CSR-AA		CSR-VA	CSR-DD	CTR-DA	
	CSRE-DA		CSRE-AA		CSRE-VA	CSRE-DD	CTRE-DA	
Operation Current	10A,25A,40A	60A,80A,100A	10A,25A,40A	60A,80A,100A	10A,25A,40A	10A,25A,40A	10A,25A,40A	60A,80A,100A,120A
Operation Voltage	24-480V AC		24-480V AC		10-250V AC	12-250V DC	24-480V AC	
Control Voltage	4-32V DC		80-250V AC		500KΩ/1/4W	3-32V DC	4-32V DC	
Control Current	DC 3-25mA		AC ≤ 12mA		/	DC 3-25mA	DC 3-25mA	
V _{TM}	≤ 1.5V	≤ 1.5V	≤ 1.5V	≤ 1.5V	≤ 1.5V	≤ 2.3V	≤ 1.5V	≤ 1.5V
I _{RRM}	≤ 10mA	≤ 20mA	≤ 10mA	≤ 20mA	≤ 5mA	≤ 5mA	≤ 15mA	≤ 15mA
T _Q	≤ 10mS		≤ 10mS		≤ 10mS	≤ 10mS	≤ 10mS	
V _{iso}	2500V AC		2500V AC		2500V AC	2500V AC	2500V AC	
R _{iso}	1000mΩ 500V DC		1000mΩ 500V DC		1000mΩ 500V DC	1000mΩ 500V DC	1000mΩ 500V DC	
T _j	-30~+80 °C		-30~+80 °C		-30~+80 °C	-30~+80 °C	-30~+80 °C	
Weight	90g	140g	90g	140g	90g	90g	350g	450g

Appearance and Dimension

CSR-DA



- Model
- CSR-10DA
 - CSR-25DA
 - CSR-40DA
 - CSR-60DA
 - CSR-80DA
 - CSR-100DA

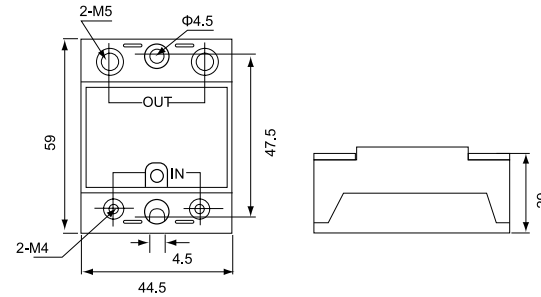

CSRE-DA



- Model
- CSRE-10DA
 - CSRE-25DA
 - CSRE-40DA
 - CSRE-60DA
 - CSRE-80DA
 - CSRE-100DA

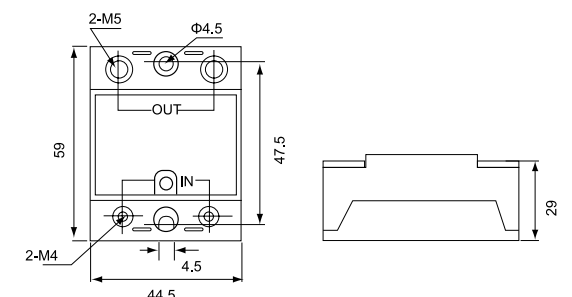

CSR-AA



- Model
- CSR-10AA
 - CSR-25AA
 - CSR-40AA
 - CSR-60AA
 - CSR-80AA
 - CSR-100AA

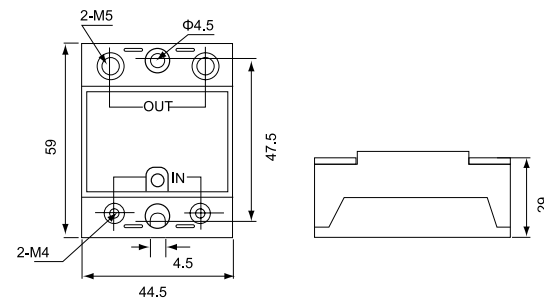

CSRE-AA



- Model
- CSRE-10AA
 - CSRE-25AA
 - CSRE-40AA
 - CSRE-60AA
 - CSRE-80AA
 - CSRE-100AA

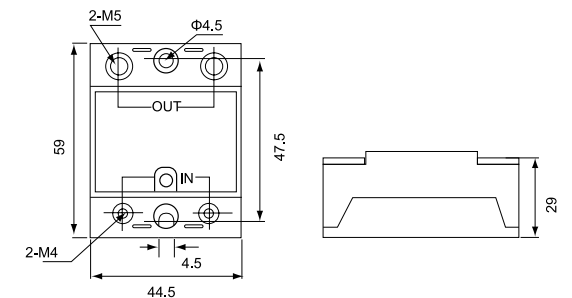

CSR-VA



- Model
- CSR-10VA
 - CSR-25VA
 - CSR-40VA

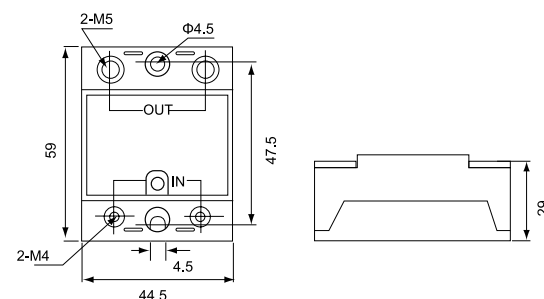

CSRE-VA



- Model
- CSRE-10VA
 - CSRE-25VA
 - CSRE-40VA

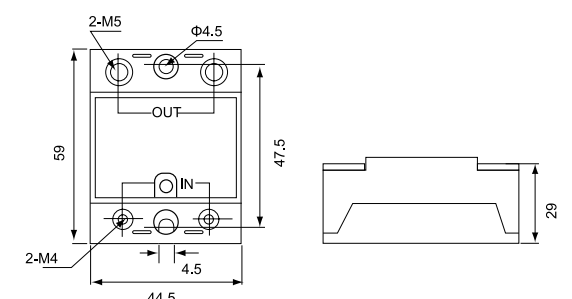

CSR-DD



- Model
- CSR-10DD
 - CSR-25DD
 - CSR-40DD

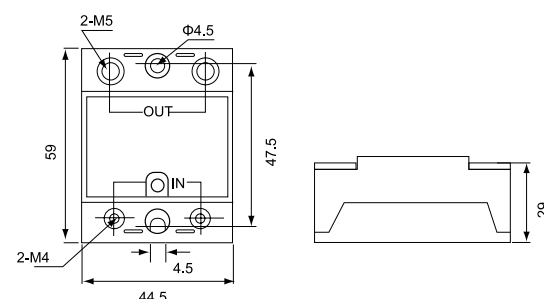

CSRE-DD



- Model
- CSRE-10DD
 - CSRE-25DD
 - CSRE-40DD

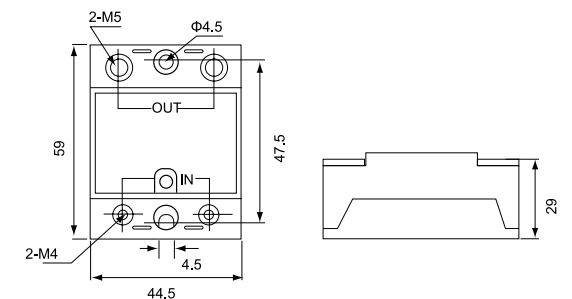

CTR-DA



- Model
- CTR-10DA
 - CTR-25DA
 - CTR-40DA
 - CTR-60DA
 - CTR-80DA
 - CTR-100DA
 - CTR-120DA

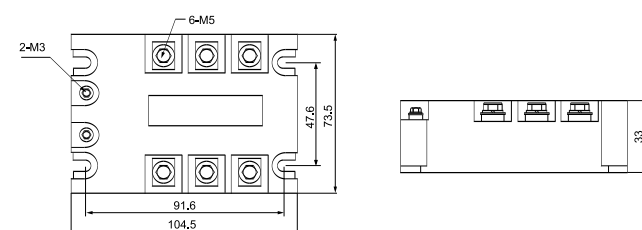

CTRE-DA

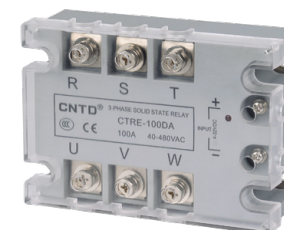

- Model
- CTRE-10DA
 - CTRE-25DA
 - CTRE-40DA
 - CTRE-60DA
 - CTRE-80DA
 - CTRE-100DA
 - CTRE-120DA

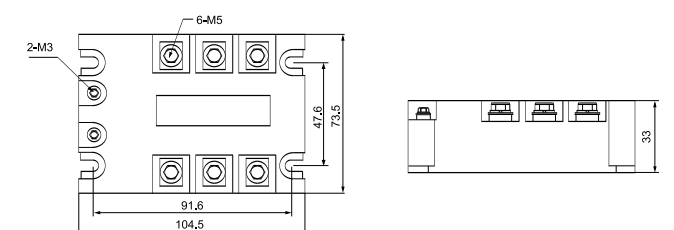

Dissipative Power Curve of CSR

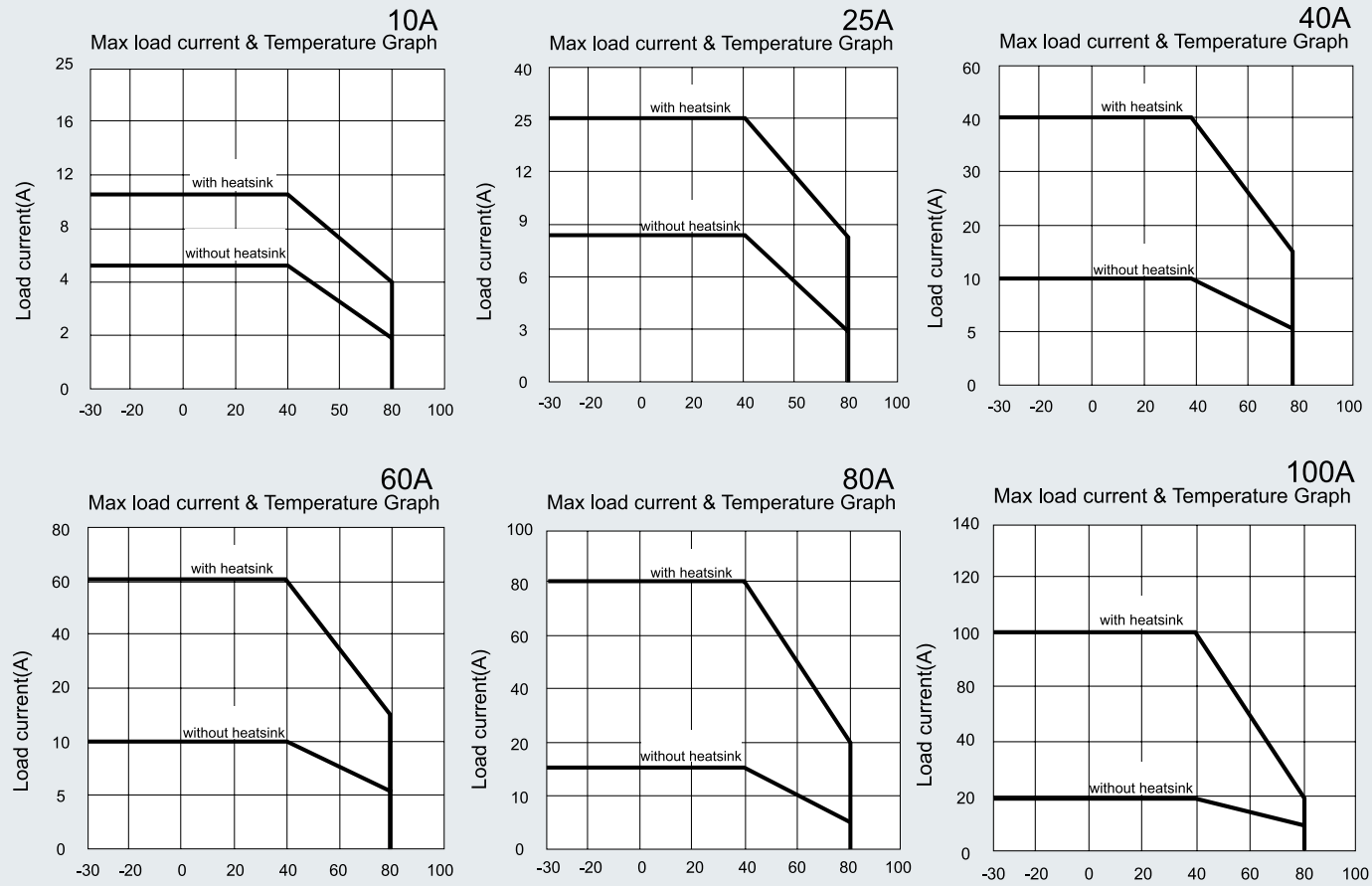

State Relay Heatsink

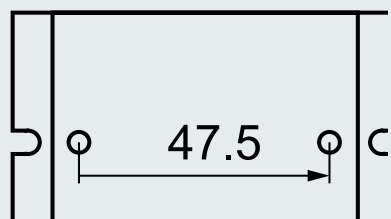
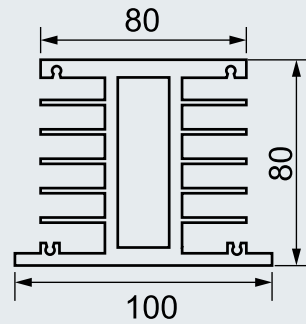
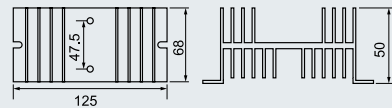
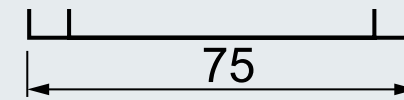

CSR-A01
(For CSR10A-40A)

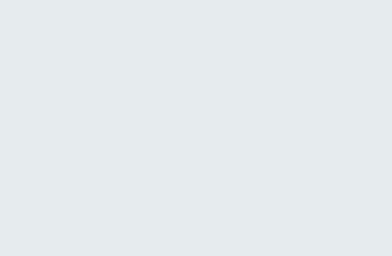

CSR-A02
(For CSR60A-100A)

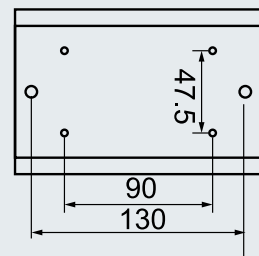

CSR-A03
(For CTR10A-120A)



Features

- Plastic shell and metal shell are for selection

Contact Form

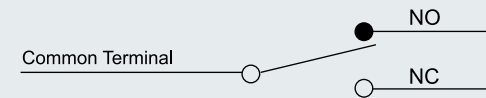

Specifications

Designation	Model	Rating	Type of switch enclosed & contact arrangement	Cable type / length	Contact	Action force	Material of Rind	
Standard type Momentary Action	CFS-101	10A 250VAC	CMV-100D	0.75mm ² ,3C/0.5 meter,1 meter~3 meter	1A1B	1.2kg	Plastic	
	CFS-102	15A 250VAC	CM-1704	0.75mm ² ,3C/1 meter,1.5 meter~2 meter	1A1B	1.1kg		
	CFS-2	10A 250VAC	CMV-100D	0.5mm ² ,3C/1 meter~3 meter	1A1B	1.1kg	Aluminum Cast	
	CFS-3	10A 250VAC	CMV-100D	0.75mm ² ,3C/0.5 meter,1 meter~3 meter	1A1B	1.2kg		
Alternate action	CFS-105	6A 250VAC	CMVS-D	0.75mm ² ,3C/1 meter,1 meter~2 meter	1A1B	2kg	Plastic	
	CFS-305	6A 250VAC	CMVS-D			3.1kg	Aluminum Cast	
	CFS-405	6A 250VAC	CMVS-D	Accessory: Cable gland (No cable)		3.1kg		
	CFS-505	6A 250VAC	CMVS-D	3.1kg				
Mini foot switch Front end push	CFS-201	10A 250VAC	CMV-100D	0.5mm ² ,3C/1 meter~3 meter	1A1B	0.7kg	Plastic	
	CFS-01	10A 250VAC	CMV-100D	0.5mm ² ,3C/1 meter~3 meter	1A1B	0.7kg		
	CFS-1	10A 250VAC	CMV-100D	0.5mm ² ,3C/1 meter~3 meter	1A1B	0.9kg	Iron	
Protective guard foot switch	CFS-302	15A 250VAC	CM-1704	Accessory: Cable gland (No cable)	1A1B	3.2kg	Aluminum Cast	
	CFS-304	15A 250VAC	CM-1704 * 2		2A2B	3.2kg		
	CFS-502	15A250VAC	CM-1704		1A1B	3.2kg		
	CFS-504	15A250VAC	CM-1704 * 2		2A2B	3.2kg		
	CFS-602	15A250VAC	Button spring type		2*1A1B	2.8kg		
	CFS-702	15A250VAC	CM-1704		2*1A1B	3.2kg		
Large type	CFS-402	15A250VAC	CM-1704	Accessory: Cable gland (No cable)	1A1B	3.2kg	Aluminum Cast	
	CFS-404	15A 250VAC	CM-1704 * 2		2A2B	3.2kg		
	CFS-802	15A 250VAC	CM-1704		2*1A1B	3.2kg		

NOTE: The default size of conduit connector is M20x1.5, outfitting cable connector. Conduit connector size is PG13.5, with product model number plus (-P), example:CFS-302-P.

Appearance and Dimension

<p>CFS-201</p>	<p>CFS-01</p>
<p>CFS-101 CFS-102 CFS-105</p>	<p>CFS-1</p>
<p>CFS-2</p>	<p>CFS-3 CFS-3S</p>
<p>CFS-302 CFS-304 CFS-305</p>	<p>CFS-402 CFS-404 CFS-405</p>
<p>CFS-502 CFS-504 CFS-505</p>	<p>CFS-602</p>
<p>CFS-702</p>	<p>CFS-802</p>



Features

- Plastic shell and metal shell are for selection

Specifications









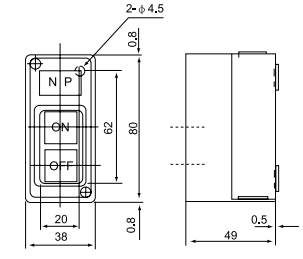

Model	Spec.	Mounting type	Connection terminal	Material
CBSN-310	3 φ 10A 1.5KW	Surface mounting	M3.5	Iron
CBSN-315	3 φ 15A 2.2KW		M4	
CBSN-330	3 φ 30A 3.7KW		M5	
CBSP-315	3 φ 15A 2.2KW	Surface mounting	M4	Plastic
CBSP-330	3 φ 30A 3.7KW		M4	
CBSY-315	3 φ 15A 2.2KW	Flush mounting	M4	Iron
CBSY-330	3 φ 30A 3.7KW		M4	
CBSS-315	3 φ 15A 2.2KW	Flush mounting	M3.5	Iron
CBSS-330	3 φ 30A 3.7KW		M4	
CPB-2	3A 250VAC	Surface mounting	M4	Plastic
CPB-3	3A 250VAC		M4	

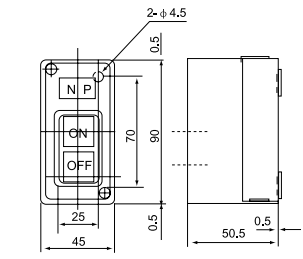
Appearance and Dimension

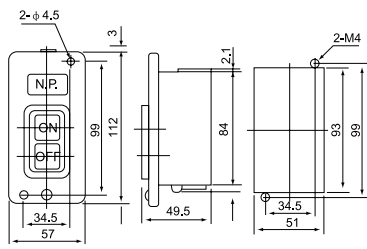
<p>CBSN-310</p>
<p>CBSN-315</p>
<p>CBSN-330</p>

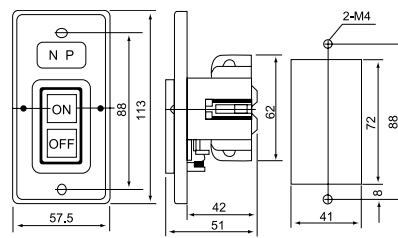

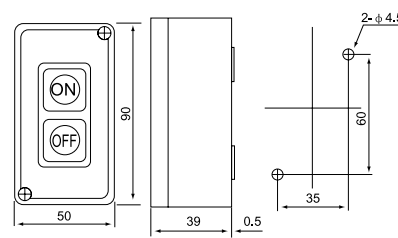
Appearance and Dimension

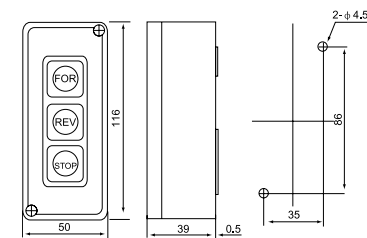
<p>CBSP-315</p> 	
<p>CBSP-330</p> 	
<p>CBSY-315 CBSY-330</p> 	
<p>CBSS-315 CBSS-330</p> 	
<p>CPB-2</p> 	
<p>CPB-3</p> 	



Features

- Smoothly and swiftly handle the lever in four directions upward, rightward, downward, and leftward
- Three alternatives of movement are attainable in each direction: Go-on, auto-return, and blockade-enforcing
- Operate in four, three, or two directions with the switch
- Rubber bushing is water-proof, oil-resistant, and dustpreventive

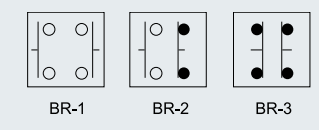

Model Number Structure

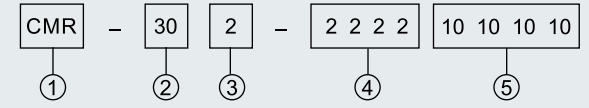

Items	Code	Description
① Type	CMR	Round type
	CMS	Square type
	CMRS	Round type
	CMRN	Seal Round
② Mounting Hole	30	Φ30m/m only
③ No.of contact Blocks fitted	1~4	1~4
④ Actuating keys	1	Go-on
	2	Auto-return
	0	Blockade-enforcing
⑤ Type of contact Blocks fitted	00	None
	10	1a(1NO)
	20	2a(2NO)
	01	1b(1NC)
	02	2b(2NC)
	11	1a1b(1NO-1NC)

Note: When you place order, please kindly designate clockwise the movement way and type of contact fitted.

Ratings

AC	Rated voltage	110V	220V	440V	
	Rated current	10A	6A	3A	
	Breaking current capacity	50A	30A	10A	
DC	Resistance Load	Rated voltage	110V	220V	600V
		Rated Current	2.2A	1.1A	0.4A
	Inductive Load	Breaking Current	2.42A	1.21A	0.44A
		Rated Current	1.2A	0.45A	0.2A
		Breaking Current	1.32A	0.5A	0.22A

Appearance and Dimension

CMR-301

CMRN-301

CMR-302

CMRN-302

CMRS-304

CMRSN-304

C-5041

Model	Voltage	Color
C-5041	12V AC/DC	R-Red
	24V AC/DC	O-Orange
	110V AC	G-Green
	220V AC	B-Blue

C-2071

Model	Voltage	Color
C-2071	12V AC/DC	R-Red
	24V AC/DC	O-Orange
	110V AC	G-Green
	220V AC	B-Blue

C-TX

Model	Voltage	Color	Sound
C-TX	12V AC/DC	R-Red	
	24V AC/DC	O-Orange	
	110V AC	G-Green	
	220V AC	B-Blue	

C-3071

Model	Voltage	Color	Sound
C-3071	12V AC/DC	R-Red	
	24V AC/DC	O-Orange	
	110V AC	G-Green	
	220V AC	B-Blue	

C-3072

Model	Voltage	Color
C-3072	12V AC/DC	R-Red
	24V AC/DC	O-Orange
	110V AC	G-Green
	220V AC	B-Blue

C-3051

Model	Voltage	Color
C-3051	12V	R-Red
	24V	O-Orange
	110V	G-Green
	220V	B-Blue

C-1081

Model	Voltage	Color	Sound
C-1081	12V	R-Red	
	24V	O-Orange	
	110V	G-Green	
	220V	B-Blue	

C-1101

Model	Voltage	Color	Sound
C-1101	12V AC/DC	R-Red	
	24V AC/DC	O-Orange	
	110V AC	G-Green	
	220V AC	B-Blue	

C-1181

Model	Voltage	Color
C-1181	12V	R-Red
	24V	O-Orange
	110V	G-Green
	220V	B-Blue

Warning Lamp



C-5111

Model	Voltage	Color
C-5111	12V AC/DC	R-Red
	24V AC/DC	O-Orange
	110V AC	G-Green
	220V AC	B-Blue

C-400

Model	Voltage	Color
C-400	12V AC/DC	R-Red
	24V AC/DC	O-Orange
	110V AC	G-Green
	220V AC	B-Blue

C-1500

Model	Voltage	Color
C-1500	12V	R-Red
	24V	O-Orange
	110V	G-Green
	220V	B-Blue

C-315

Model	Voltage	Color
C-315	12V	R-Red
	24V	O-Orange
	110V	G-Green
	220V	B-Blue

Warning Lamp

Model Number Structure

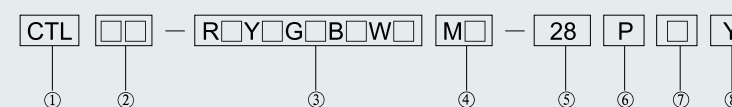

① Series	CTL	Warning Lamp Series	
② Outline dimension appearance and style	50	50 Outside diameter dimension	
	70	70 Outside diameter dimension	
	702	70 Flat stitching	
	701	70 Single lamp style	
	801	80 Singlelamp style	
③ Color	R	● R: Red	● G: Green ● Y: Yellow ● B: Blue ○ W: White
	M	With buzzer	
④ Signal type	MD	With a separate buzzer	
	M	1	Continuous Ring
		2	Discontinuous Ring
		3	Discontinuous Ring, delay close
		No digital representative discontinuous Ring	
⑤ Voltage	AC.DC	22	12V
		23	24V
		24	36V
		25	48V
	AC	30	110V
		31	220V
	32	3800V	
⑥ Installation method	P	Vertical base	
	Z	Collapsible universal base	
	C	Side mounting base	
	No letters	No letters(pagerback base)	
⑦ Poling scale(mm)	CTL50	1	87
		2	142
		3	242
	CTL70/90	1	58
		2	88
		3	118
		4	168
	5	218	
	6	268	
	7	318	
⑧ Mounting base		Add the base	

Warning Lamp



Warning Lamp



Model
CTL50-R-31P2
CTL50-RG-31P2
CTL50-RYG-31P2
CTL50-RYGB-31P2
CTL50-RYGBW-31P2
CTL50-RM-23P2
CTL50-RGM-23P2
CTL50-RYGM-23P2
CTL50-RYGBM-23P2
CTL50-RYGBWM-23P2

CTL50



Model
CTL50-R-31Z2
CTL50-RG-31Z2
CTL50-RYG-31Z2
CTL50-RYGB-31Z2
CTL50-RYGBW-31Z2
CTL50-RM-23Z2
CTL50-RGM-23Z2
CTL50-RYGM-23Z2
CTL50-RYGBM-23Z2
CTL50-RYGBWM-23Z2

CTL50



Model
CTL701-R-31
CTL701-RM-31
CTL701-RGB-23
CTL701-RGBM-23

CTL701



Model
HTL701-R-31P4
HTL701-R-31Z4
HTL701-R-31C5
HTL701-RM-31P4
HTL701-RM-31Z4
HTL701-RM-31C5
HTL701-RGB-23P4
HTL701-RGB-23Z2
HTL701-RGB-23C5
HTL701-RGBM-23P2
HTL701-RGBM-23Z2
HTL701-RGBM-23C5

CTL701



Model
CTL50-R-31C3
CTL50-RG-31C3
CTL50-RYG-31C3
CTL50-RYGB-31C3
CTL50-RYGBW-31C3
CTL50-RM-23C3
CTL50-RGM-23C3
CTL50-RYGM-23C3
CTL50-RYGBM-23C3
CTL50-RYGBWM-23C3

CTL50



Model
CTL70-R-31P4
CTL70-RG-31P4
CTL70-RYG-31P4
CTL70-RYGB-31P4
CTL70-RYGBW-31P4
CTL70-RM-23P4
CTL70-RGM-23P4
CTL70-RYGM-23P4
CTL70-RYGBM-23P4
CTL70-RYGBWM-23P4

CTL70



Model
CTL901-R-31
CTL901-RM-31
CTL901-RGB-23
CTL901-RGBM-23

CTL901



Model
CTL70-R-31P4
CTL70-RG-31P4
CTL70-RYG-31P4
CTL70-RYGB-31P4
CTL70-RYGBW-31P4
CTL70-RM-23P4
CTL70-RGM-23P4
CTL70-RYGM-23P4
CTL70-RYGBM-23P4
CTL70-RYGBWM-23P4

CTL901



Model
CTL70-R-31Z4
CTL70-RG-31Z4
CTL70-RYG-31Z4
CTL70-RYGB-31Z4
CTL70-RYGBW-31Z4
CTL70-RM-23Z4
CTL70-RGM-23Z4
CTL70-RYGM-23Z4
CTL70-RYGBM-23Z4
CTL70-RYGBWM-23Z4

CTL70



Model
CTL70-R-31C5
CTL70-RG-31C5
CTL70-RYG-31C5
CTL70-RYGB-31C5
CTL70-RYGBW-31C5
CTL70-RM-23C5
CTL70-RGM-23C5
CTL70-RYGM-23C5
CTL70-RYGBM-23C5
CTL70-RYGBWM-23C5

CTL70



Model
CTL801-R-31
CTL801-RM-31
CTL801-RGB-23
CTL801-RGBM-23

CTL801

Warning Lamp



Model Number Structure

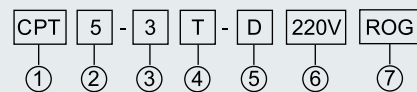

Item	Code	Description
① Type	CPT CPTL CPTLZ CPTLS	Rod(Aluminum pole with L-shaped bracket to be installed) Conjoined disc Conjoined adjustable(Aluminum rod 90 ° regulating installation) Rod footplate(Aluminum rod with disk installation)
② Lamp shell outside diameter size	4 5 6	φ 40 φ 50 φ 60
③ The layer number of lights	1-5	1-5 layer
④ Function	T W U K	Always Flash Always buzzer Flash buzzer
⑤ Lamp Type	E D	Tungsten filament bulbs LED bulbs
⑥ Voltage	12V- 220V	12V AC/DC 24V AC/DC 110V AC 220V AC
⑦ Lamp shell color	R O G B W	Red Orange Green Blue White

CPT5

Model	Voltage	Color	Sound
CPT5	12V	R- Red	
	24V	O- Orange	
	110V	G- Green	
	220V	B- Blue	

CPTL5

Model	Voltage	Color	Sound
CPTL5	12V	R- Red	
	24V	O- Orange	
	110V	G- Green	
	220V	B- Blue	

CPT4

Model	Voltage	Color	Sound
CPT4	12V	R- Red	
	24V	O- Orange	
	110V	G- Green	
	220V	B- Blue	

CPTL4

Model	Voltage	Color	Sound
CPTL4	12V	R- Red	
	24V	O- Orange	
	110V	G- Green	
	220V	B- Blue	

CPT7

Model	Voltage	Color	Sound
CPT7	12V	R- Red	
	24V	O- Orange	
	110V	G- Green	
	220V	B- Blue	

C-3093

Model	Voltage	Color	Sound
C-3093	12V	R- Red	
	24V	O- Orange	
	110V	G- Green	
	220V	B- Blue	

Motor Siren

CMS-190			CMS-290			CMS-390		
Model	Voltage	Sound	Model	Voltage	Sound	Model	Voltage	Sound
CMS-190	12V		CMS-290	12V		CMS-390	12V	
	24V			24V			24V	
	110V			110V			110V	
	220V			220V			220V	

Buzzer

C-F75	C-F80	C-F25	C-F1

Warning Lamp Accessories

CTL50/70/90-ZC-Z	CTL50/70/90-SZ		

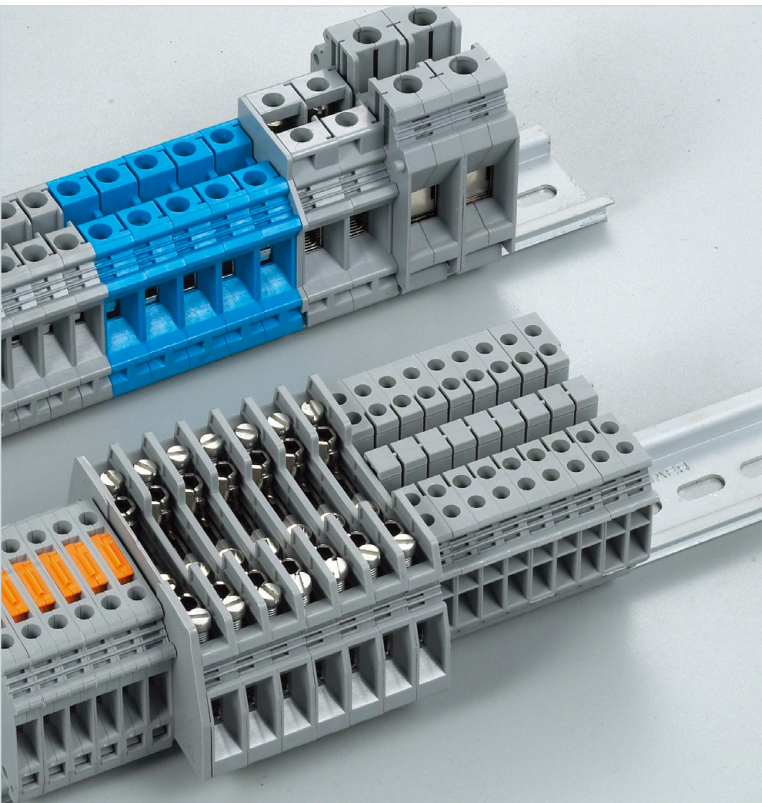

Parameters

Instructions

- (1) End clapboard
- (2) Center connecting piece:
Use at the center of terminal for transverse bridge connection
- (3) Side connecting piece: 2 digit
3 digit
10 digit
- (4) Mark symbol:
1-100, 10 for a group. Please explain if you have special demand.
- (5) Septa: The spacer used in the electric segregation among the adjoint hooknp. Can insert after installation.
- (6) The packet clapboard
- (7) Universal terminal fixture

Appearance and Dimension

<p>CUK 2.5B</p> <table border="1" style="width: 100%; border-collapse: collapse;"> <tr> <td>(mm²)</td> <td>(mm²)</td> <td></td> </tr> <tr> <td>CE 0.2-4 32A</td> <td>0.2-2.5 800V</td> <td>(ZB6) □ ▽</td> </tr> </table>	(mm ²)	(mm ²)		CE 0.2-4 32A	0.2-2.5 800V	(ZB6) □ ▽	<p>CUK 3N</p> <table border="1" style="width: 100%; border-collapse: collapse;"> <tr> <td>(mm²)</td> <td>(mm²)</td> <td></td> </tr> <tr> <td>CE 0.2-4 32A</td> <td>0.2-2.5 800V</td> <td>(ZB5) □ ▽</td> </tr> </table>	(mm ²)	(mm ²)		CE 0.2-4 32A	0.2-2.5 800V	(ZB5) □ ▽	<p>CUK 5N</p> <table border="1" style="width: 100%; border-collapse: collapse;"> <tr> <td>(mm²)</td> <td>(mm²)</td> <td></td> </tr> <tr> <td>CE 0.2-6 41A</td> <td>0.2-4 800V</td> <td>(ZB6) □ ▽</td> </tr> </table>	(mm ²)	(mm ²)		CE 0.2-6 41A	0.2-4 800V	(ZB6) □ ▽
(mm ²)	(mm ²)																			
CE 0.2-4 32A	0.2-2.5 800V	(ZB6) □ ▽																		
(mm ²)	(mm ²)																			
CE 0.2-4 32A	0.2-2.5 800V	(ZB5) □ ▽																		
(mm ²)	(mm ²)																			
CE 0.2-6 41A	0.2-4 800V	(ZB6) □ ▽																		

<p>CUK 6N</p> <table border="1" style="width: 100%; border-collapse: collapse;"> <tr> <td>(mm²)</td> <td>(mm²)</td> <td></td> </tr> <tr> <td>CE 0.2-10 57A</td> <td>0.2-6 800V</td> <td>(ZB8) □ ▽</td> </tr> </table>	(mm ²)	(mm ²)		CE 0.2-10 57A	0.2-6 800V	(ZB8) □ ▽	<p>CUK 10N</p> <table border="1" style="width: 100%; border-collapse: collapse;"> <tr> <td>(mm²)</td> <td>(mm²)</td> <td></td> </tr> <tr> <td>CE 0.5-16 76A</td> <td>0.5-10 800V</td> <td>(ZB10) □ ▽</td> </tr> </table>	(mm ²)	(mm ²)		CE 0.5-16 76A	0.5-10 800V	(ZB10) □ ▽	<p>CUK 16N</p> <table border="1" style="width: 100%; border-collapse: collapse;"> <tr> <td>(mm²)</td> <td>(mm²)</td> <td></td> </tr> <tr> <td>CE 2-25 101A</td> <td>4-16 800V</td> <td>(ZB10) □ ▽</td> </tr> </table>	(mm ²)	(mm ²)		CE 2-25 101A	4-16 800V	(ZB10) □ ▽
(mm ²)	(mm ²)																			
CE 0.2-10 57A	0.2-6 800V	(ZB8) □ ▽																		
(mm ²)	(mm ²)																			
CE 0.5-16 76A	0.5-10 800V	(ZB10) □ ▽																		
(mm ²)	(mm ²)																			
CE 2-25 101A	4-16 800V	(ZB10) □ ▽																		
<p>CUK 35</p> <table border="1" style="width: 100%; border-collapse: collapse;"> <tr> <td>(mm²)</td> <td>(mm²)</td> <td></td> </tr> <tr> <td>CE 10-35 125A</td> <td>10-35 800V</td> <td>(ZB10) □ ▽</td> </tr> </table>	(mm ²)	(mm ²)		CE 10-35 125A	10-35 800V	(ZB10) □ ▽	<p>CUKH 50</p> <table border="1" style="width: 100%; border-collapse: collapse;"> <tr> <td>(mm²)</td> <td>(mm²)</td> <td></td> </tr> <tr> <td>CE 16-50 150A</td> <td>25-50 1000V</td> <td>(ZB10) □ ▽</td> </tr> </table>	(mm ²)	(mm ²)		CE 16-50 150A	25-50 1000V	(ZB10) □ ▽	<p>CUKH 95</p> <table border="1" style="width: 100%; border-collapse: collapse;"> <tr> <td>(mm²)</td> <td>(mm²)</td> <td></td> </tr> <tr> <td>CE 25-95 232A</td> <td>35-95 1000V</td> <td>(ZB10) □ ▽</td> </tr> </table>	(mm ²)	(mm ²)		CE 25-95 232A	35-95 1000V	(ZB10) □ ▽
(mm ²)	(mm ²)																			
CE 10-35 125A	10-35 800V	(ZB10) □ ▽																		
(mm ²)	(mm ²)																			
CE 16-50 150A	25-50 1000V	(ZB10) □ ▽																		
(mm ²)	(mm ²)																			
CE 25-95 232A	35-95 1000V	(ZB10) □ ▽																		
<p>CUKK 3</p> <table border="1" style="width: 100%; border-collapse: collapse;"> <tr> <td>(mm²)</td> <td>(mm²)</td> <td></td> </tr> <tr> <td>CE 0.2-4 32A</td> <td>0.2-2.5 500V</td> <td>(ZB5) □ ▽</td> </tr> </table>	(mm ²)	(mm ²)		CE 0.2-4 32A	0.2-2.5 500V	(ZB5) □ ▽	<p>CUKK 5</p> <table border="1" style="width: 100%; border-collapse: collapse;"> <tr> <td>(mm²)</td> <td>(mm²)</td> <td></td> </tr> <tr> <td>CE 0.2-4 32A</td> <td>0.2-4 500V</td> <td>(ZB6) □ ▽</td> </tr> </table>	(mm ²)	(mm ²)		CE 0.2-4 32A	0.2-4 500V	(ZB6) □ ▽	<p>CUDK4</p> <table border="1" style="width: 100%; border-collapse: collapse;"> <tr> <td>(mm²)</td> <td>(mm²)</td> <td></td> </tr> <tr> <td>CE 0.2-6 32A*</td> <td>0.2-4 690V</td> <td>(ZB6) □ ▽</td> </tr> </table>	(mm ²)	(mm ²)		CE 0.2-6 32A*	0.2-4 690V	(ZB6) □ ▽
(mm ²)	(mm ²)																			
CE 0.2-4 32A	0.2-2.5 500V	(ZB5) □ ▽																		
(mm ²)	(mm ²)																			
CE 0.2-4 32A	0.2-4 500V	(ZB6) □ ▽																		
(mm ²)	(mm ²)																			
CE 0.2-6 32A*	0.2-4 690V	(ZB6) □ ▽																		



CUK3-TWIN

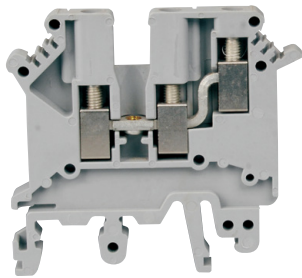

(mm ²)	(mm ²)	(ZB5)
CE 0.2-2.5	0.2-2.5	□ □
24A*	400V	

CUK5-TWIN

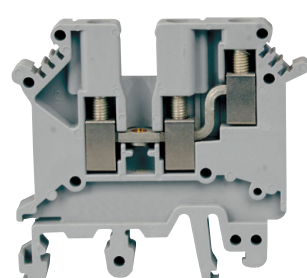

(mm ²)	(mm ²)	(ZB6)
CE 0.2-4	0.2-4	□ □
32A*	500V	

CUK5-HESI

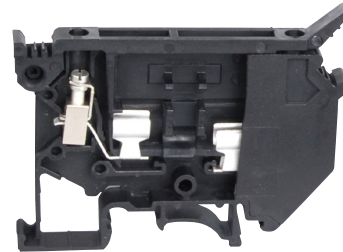

(mm ²)	(mm ²)	(ZB8)
CE 0.2-4	0.2-4	□ □
6.3A	800V	

CUK10-DREHSI

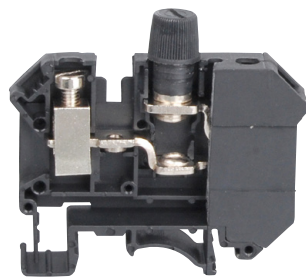

(mm ²)	(mm ²)	(ZB8)
CE 10A	800V	□ □

CURTK/S

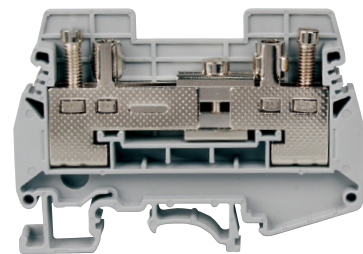

(mm ²)	(mm ²)	(ZB8)
CE 0.5-10	0.5-6	□ □
57A	400V	

CUK5-MTK-P/P

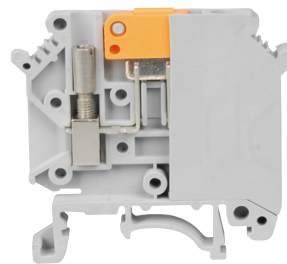

(mm ²)	(mm ²)	(ZB6)
CE 0.2-4	0.2-4	□ □
16A	800V	

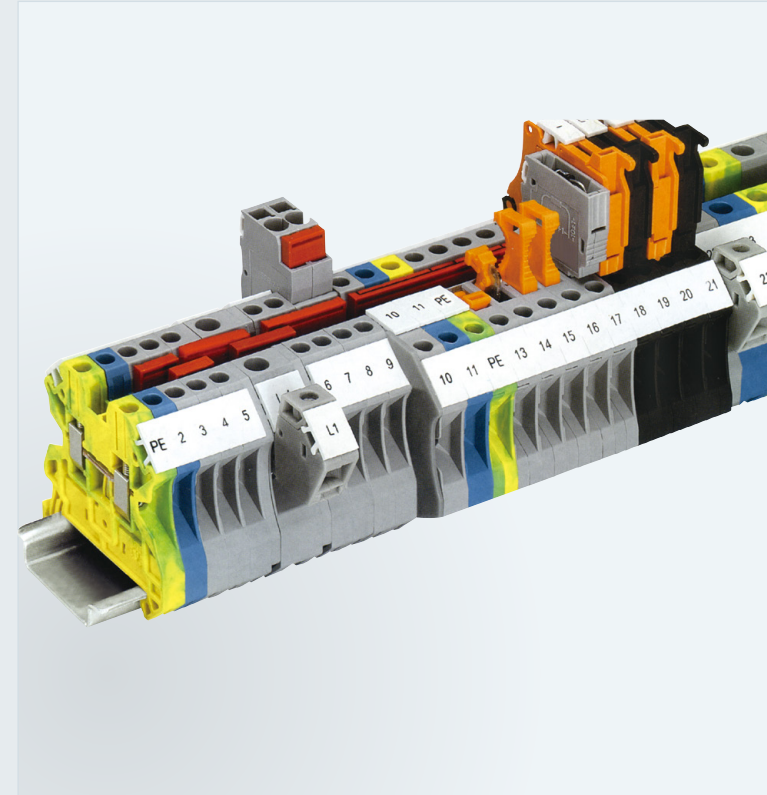

Appearance and Dimension

CUSLKG 2.5

(mm ²)	(mm ²)
CE 0.2-4	0.2-2.5
32A	
(ZB6)	□ □



CUSLKG 3

(mm ²)	(mm ²)
CE 0.2-4	0.2-2.5
34A	
(ZB5)	□ □



CUSLKG 5

(mm ²)	(mm ²)
CE 0.2-4	0.2-4
34A	
(ZB6)	□ □

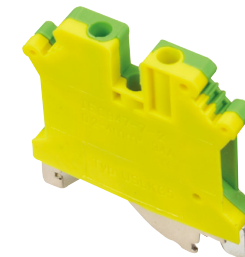

CUSLKG 6

(mm ²)	(mm ²)
CE 0.2-10	0.2-6
37A	
(ZB8)	□ □

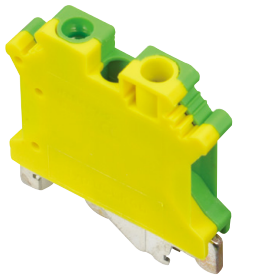

CUSLKG 10

(mm ²)	(mm ²)
CE 0.5-16	0.5-10
76A	
(ZB10)	□ □

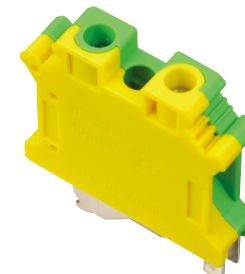

CUSLKG 16

(mm ²)	(mm ²)
CE 2.5-25	4-16
101A	
(ZB10)	□ □

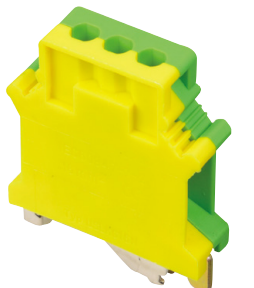

CUSLKG 35

(mm ²)	(mm ²)
CE 10-35	10-35
125A	
(ZB10)	□ □

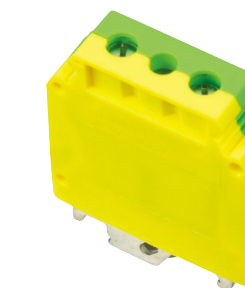

CUSLKG 50

(mm ²)	(mm ²)
CE 16-50	25-50
150A	
(ZB10)	□ □



CBD Double-layer Plate Type Screw Crimping Terminal

CBD-10

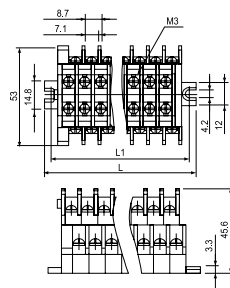

L=21.6+8.7 × n
L1=15.2+8.7 × n
n=No. of Poles

CBD-20

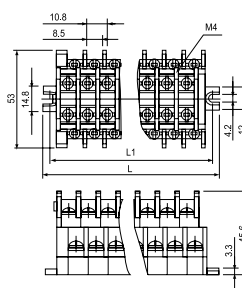

L=20.6+10.8 × n
L1=15.2+10.8 × n
n=No. of Poles

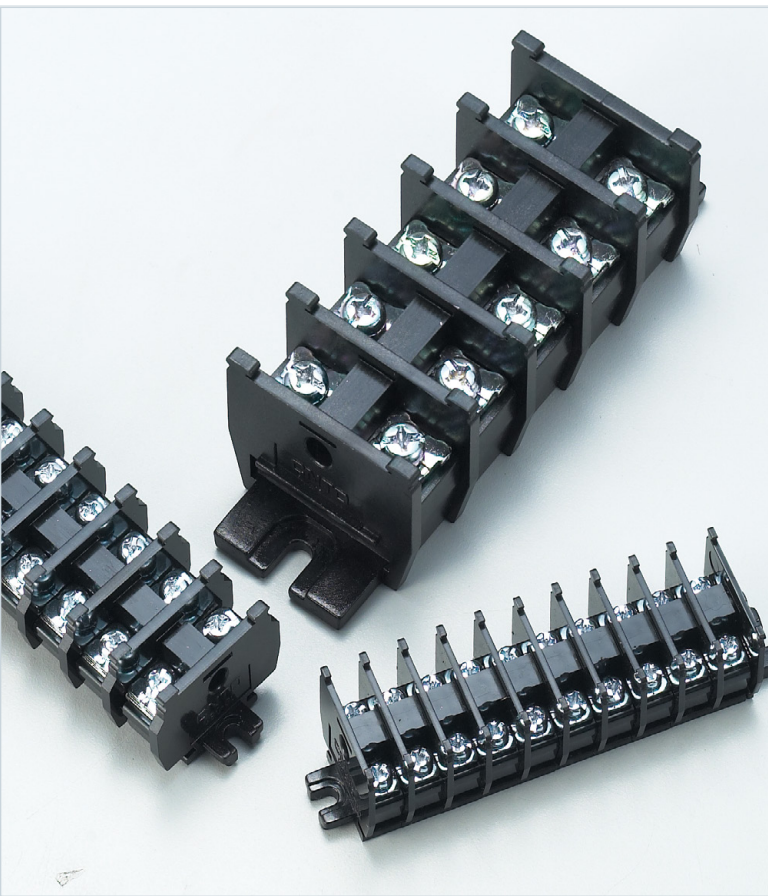

Features

- Under 10P: no need for concatenated guide rail. 2P: can be mutual pressed directly. Installation is convenient and fast
- More than 10P: additional guide rail. More than 20P: can be divided into two or three parts and settle one part, length is not limited
- PC material, heat resistance, strong structure

Appearance and Dimension

CBC-10

$L=16.7+8.6 \times n$
 $L1=10.3+8.6 \times n$
 n=No. of poles

CBC-20

$L=17.3+10.8 \times n$
 $L1=11.2+10.8 \times n$
 n=No. of poles

CBC-30

$L=18+13.1 \times n$
 $L1=11.5+13.1 \times n$
 n=No. of poles

CBC-60

$L=33.5+20.4 \times n$
 $L1=18.5+20.4 \times n$
 n=No. of poles

CBC-100

$L=34+27 \times n$
 $L1=19+27 \times n$
 n=No. of poles

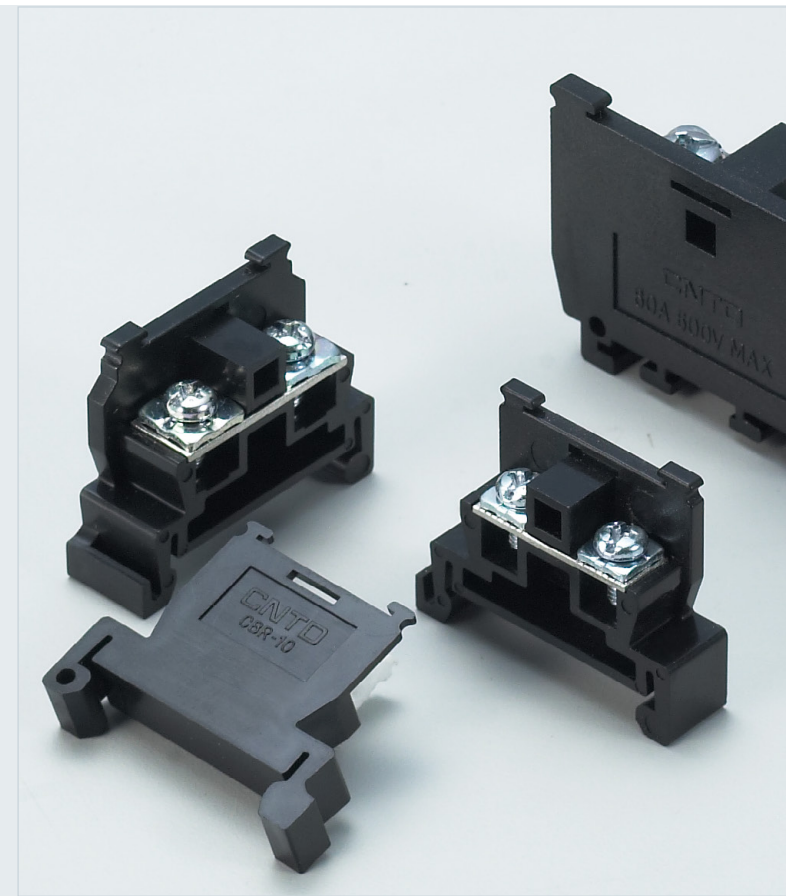

Features

- Combining: one terminal plate end hooks slide under the skeletons end and press hard
- Disassembly: with straight screwdriver stand into a groove, pry up one end
- PC material, heat resistance, strong structure

Appearance and Dimension

CBR-10

$L=38+8.9 \times n$
 $L1=22.5+8.9 \times n$
 n=No. of poles

CBR-20

$L=38+10.8 \times n$
 $L1=22.5+10.8 \times n$
 n=No. of poles

CBR-30

$L=38+13.1 \times n$
 $L1=22.5+13.1 \times n$
 n=No. of poles

CBR-60

$L=38+20.4 \times n$
 $L1=22.5+20.4 \times n$
 n=No. of poles

CBR-100

$L=38+27 \times n$
 $L1=22.5+27 \times n$
 n=No. of poles