

Limit Switch Division

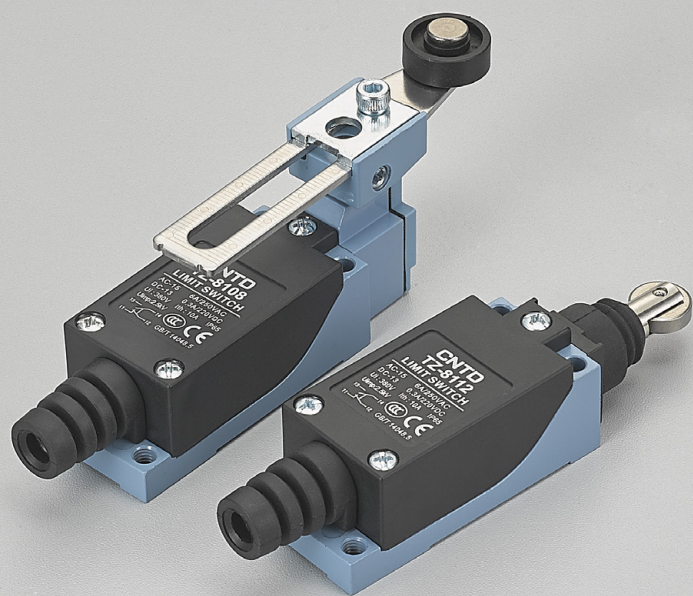

TZ-8 Vertical Limit Switch	A01-02
CZ-8 □ N Vertical Limit Switch	A03-04
CWL Vertical Limit Switch	A05-07
CHL Vertical Limit Switch	A08-09
CSA Vertical Limit Switch	A10-11
CLS Vertical Limit Switch	A12-15
C4N Vertical Safety Limit Switch	A16-20
C4N- □ R Vertical Manual Reset Safety Limit Switch	A21-24
C4B- □ N Vertical Safety Limit Switch	A25-28
TZ-6 Horizontal Limit Switch	A29-30
CZ-93 Vertical Interlock Safety Limit Switch	A31-32
CZ-3 Vertical Limit Switch	A33-35
C6N Vertical Safety Limit Switch	A36-43
CZE Limit Switch	A44-49
CM Micro Switch	A50-53
CM- □ N Micro Switch	A54-56
CZ-7 Horizontal Limit Switch	A57-58
CMV10 Miniature Snap Action Switch	A59-60
CMV16 Miniature Snap Action Switch	A61-62





Features

- Double circuit type of limit switch
- High mechanical strength, consists of intensive plastic and aluminum cast
- Small size, water-proof and oil-proof construction
- Built-in contact box has double-spring and long mechanical life
- Smooth operation with larger over travel distance
- Conduit design for convenient cabling
- Various actuators for different applications

Contact Form

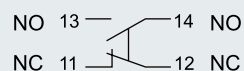

Ratings

Rated Voltage	Noninductive Load (A)				Inductive Load (A)			
	Resistance Load		Lamp Load		Inductive Load		Motor Load	
	NC	NO	NC	NO	NC	NO	NC	NO
125VAC	5	5	1.5	0.7	3	3	2	1
250VAC	5	5	1	0.5	3	3	1.5	0.8
8VDC	5	5	3	3	5	4	3	3
14VDC	5	5	3	3	4	4	3	3
30VDC	5	5	3	3	4	4	3	3
125VDC	0.4	0.4						
250VDC	0.2	0.2						
Inrush Current	N.C: below 24A, N.O: below 12A							

NOTES: 1. Inductive load has a power factor of 0.4 min.(AC) and a time constant of 7 msec. max.(DC).
 2. Lamp load has an inrush current of 10 times the steady-state current, while motor load has an inrush current of 6 times the steady-state current.
 3. Product with spring, its usable range of operating part is within one third of the whole spring length from the front end of spring.

Specifications

Operation speed	5mm-0.5m/s
Operating frequency	Electical: 30 operations/min
Contact resistance	25mΩ max. (initial value)
Insulation resistance	100mΩ min. (below 500VDC)
Dielectric strength	1000VAC, 50/60 Hz for 1 minute between terminals of the same polarity
	1500VAC, 50/60 Hz for 1 minute between current-carrying and non-current-carrying metal parts
Vibration	1500VAC, 50/60 Hz for 1 minute between each terminal and ground
	10-55Hz, 1.5mm double amplitude
Shock	Mechanical durable: 1,000m/Sec ² (about 100G'S)
	Malfunction: 300m/Sec ² (about 30G'S)
Ambient temperature	Using: -20~+70°C (With no icing)
Humidity	<95% RH
Electrical life	500,000 operations above
Degree of protection	IP65

Operating Characteristics

Model	TZ-8	TZ-8104	TZ-8108	TZ-8109	TZ-8107	TZ-8111	TZ-8112/8122	TZ-8166/8167/8168/8169
Operating force	OF(Max.)	750g	750g	750g	750g	900g	900g	150g
Release force	RF(Min.)	100g	100g	100g	100g	150g	150g	-
Pre-travel	PT(Max.)	20°	20°	20°	20°	1.5mm	1.5mm	30mm
Over travel	OT(Min.)	50°	50°	50°	50°	4mm	4mm	-
Movement differential	MD(Max.)	12°	12°	12°	12°	1mm	1mm	-
Operating position	OP(mm.)	-	-	-	-	26 ± 0.8mm	37 ± 0.8mm	-

Appearance and Dimension

TZ-8104

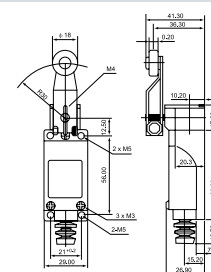

TZ-8105

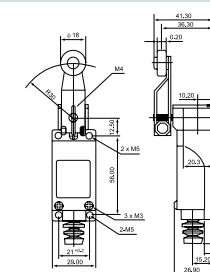

TZ-8107

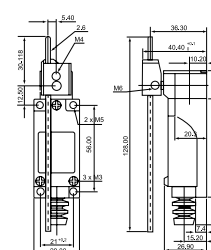

TZ-8108

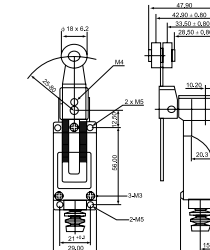

TZ-8109

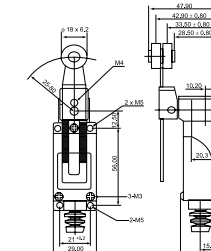

TZ-8111

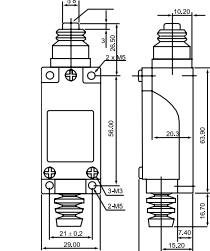

TZ-8112

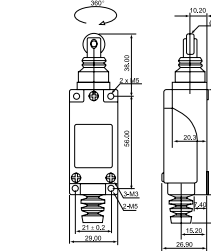

TZ-8122

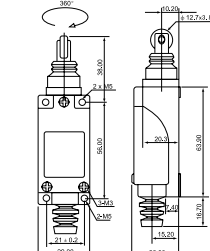

TZ-8166

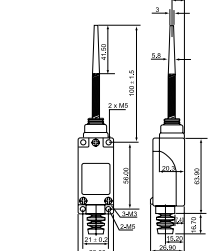

TZ-8167

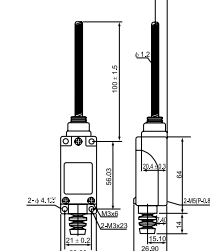

TZ-8168

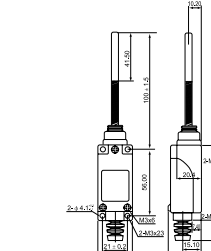

TZ-8169

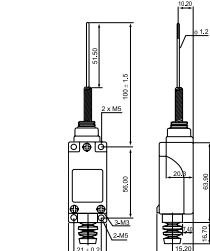

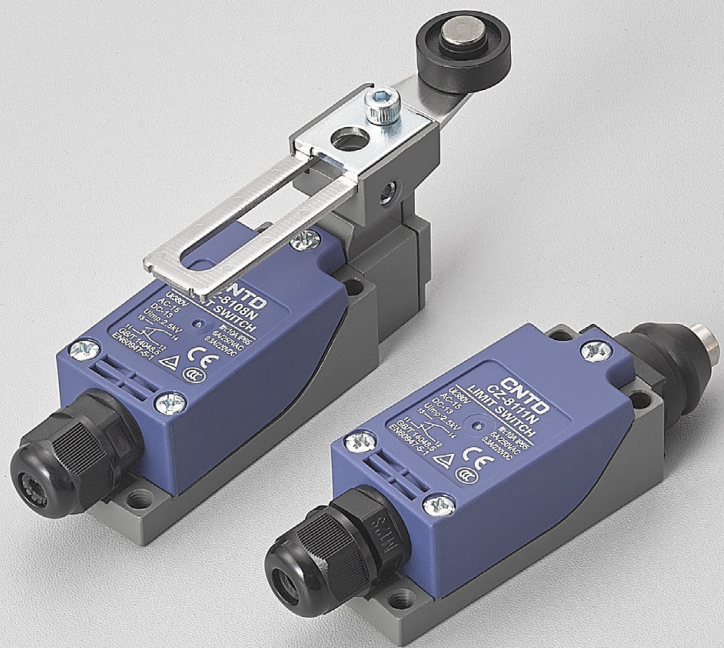

Features

- Double circuit type of limit switch
- High mechanical strength, consists of intensive plastic and aluminum cast
- Small size, water-proof and oil proof construction
- Built-in contact box has double-spring and long mechanical life
- Smooth operation with larger over travel distance
- Various actuators for different application
- Optimize tail line design to improve sealing performance

Contact Form

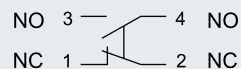

Ratings

Rated Voltage	Noninductive Load (A)				Inductive Load (A)			
	Resistance Load		Lamp Load		Inductive Load		Motor Load	
	NC	NO	NC	NO	NC	NO	NC	NO
125VAC	5	5	1.5	0.7	3	3	2	1
250VAC	5	5	1	0.5	3	3	1.5	0.8
8VDC	5	5	3	3	5	4	3	3
14VDC	5	5	3	3	4	4	3	3
30VDC	5	5	3	3	4	4	3	3
125VDC	0.4	0.4						
250VDC	0.2	0.2						
Inrush Current	N.C: below 24A, N.O: below 12A							

NOTES: 1. Inductive load has a power factor of 0.4 min.(AC) and a time constant of 7 msec. max.(DC).
 2. Lamp load has an inrush current of 10 times the steady-state current, while motor load has an inrush current of 6 times the steady-state current.
 3. Product with spring, its usable range of operating part is within one third of the whole spring length from the front end of spring.

Specifications

Operation speed	5mm-0.5m/s
Operating frequency	Electical: 30 operations/min
Contact resistance	25mΩ max. (initial value)
Insulation resistance	100mΩ min. (below 500VDC)
Dielectric strength	1000VAC, 50/60 Hz for 1 minute between terminals of the same polarity
	1500VAC, 50/60 Hz for 1 minute between current-carrying and non-current-carrying metal parts
	1500VAC, 50/60 Hz for 1 minute between each terminal and ground
Vibration	10-55Hz, 1.5mm double amplitude
Shock	Mechanical durable: 1,000m/Sec ² (about 100G'S) Malfunction: 300m/Sec ² (about 30G'S)
Ambient temperature	Using: -20~+70°C (With no icing)
Humidity	<95% RH
Electrical life	500,000 operations above
Degree of protection	IP65

Operating Characteristics

Model	CZ-8 □ N	CZ-8104N CZ-8105N	CZ-8108N CZ-8109N	CZ-8107N	CZ-8111N	CZ-8112N CZ-8122N	CZ-8166N/8167N/8168N/8169N
Operating force	OF(Max.)	750g	750g	750g	900g	900g	150g
Release force	RF(Min.)	100g	100g	100g	150g	150g	-
Pre-travel	PT(Max.)	20°	20°	20°	1.5mm	1.5mm	30mm
Over travel	OT(Min.)	50°	50°	50°	4mm	4mm	-
Movement differential	MD(Max.)	12°	12°	12°	1mm	1mm	-
Operating position	OP(mm.)	-	-	-	26 ± 0.8mm	37 ± 0.8mm	-

Appearance and Dimension

CZ-8104N		CZ-8105N	
CZ-8107N		CZ-8108N	
CZ-8109N		CZ-8111N	
CZ-8112N		CZ-8122N	
CZ-8166N		CZ-8167N	
CZ-8168N		CZ-8169N	

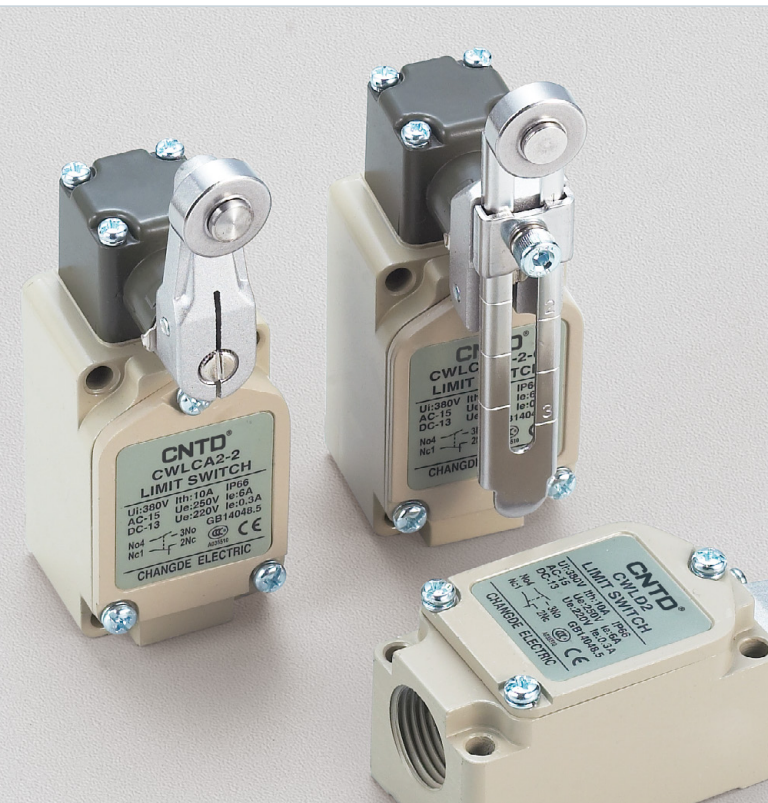

Features

- Double-circuit type of limit switch
- High mechanical strength, mainly consists of aluminum cast
- Water-proof and oil-proof construction
- Various actuators for different applications
- Built-in contact box with double spring mechanism, longer mechanical life

Contact Form

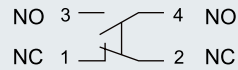

Ratings

Rated Voltage	Noninductive Load (A)				Inductive Load (A)			
	Resistance Load		Lamp Load		Inductive Load		Motor Load	
	NC	NO	NC	NO	NC	NO	NC	NO
125VAC	10	3	1.5	10	5	2.0		
250VAC	5	2	1	5	3	1.0		
480VAC	3	1.5	0.8	3	1.5	0.8		
600VAC	1	1	0.5	1.5	1	0.5		
8VDC	10	6	3	10		6		
14VDC	10	6	3	10		6		
30VDC	6	4	3	6		4		
125VDC	0.8	0.2	0.2	0.8		0.2		
250VDC	0.4	0.1	0.1	0.4		0.1		

NOTES: 1. Inductive load has a power factor of 0.4 min.(AC) and a time constant of 7 msec. max.(DC).
 2. Lamp load has an inrush current of 10 times the steady-state current, while motor load has an inrush current of 6 times the steady-state current.
 3. Product with spring, its usable range of operating part is within one third of the whole spring length from the front end of spring.

Specifications

Operation speed	1mm-1m/s
Operating frequency	Electical: 30 operations/min
Contact resistance	25mΩ max. (initial value)
Insulation resistance	100mΩ min. (below 500VDC)
Dielectric strength	1500VAC, 50/60 Hz for 1 minute between current-carrying and non-current-carrying metal parts
	1500VAC, 50/60 Hz for 1 minute between current-carrying and non-current-carrying metal parts
	1500VAC, 50/60 Hz for 1 minute between each terminal and ground
Vibration	10-55Hz, 1.5mm double amplitude
Shock	Mechanical durable: 1, 000m/Sec ² (about 100G'S)
	Malfunction: 300m/Sec ² (about 30G'S)
Ambient temperature	Using: -20~+80°C (With no icing)
Humidity	<95% RH
Electrical life	500,000 operations above
Protection level	IP66

NOTES: The default size of conduit connector is M20x1.5, outfitting cable connector. Conduit connector size is PG13.5, with product model number plus (-P), example: CWLCA2-2-P.

Operating Characteristics

Model	CWL	CWLCA2-2	CWLD2	CWLNJ	CWLNJ-S2	CWLCA12-2-Q	CWLCA12-2-QD	CWLCL	CWLCA32-41	CWLCA32-42	CWLD	CWLNJ-2	CWLNJ-30	CWLD1	CWLD3
Operating Force	OF(Max.)	1360g	2720g	150g	29g	1360g	142g	1200g	2720g	120g	80g	2720g	2720g		
Release Force	RF(Min.)	227g	910g	-	-	227g	28g	-	910g	-	-	910g	910g		
Pre-Travel	PT(Max.)	20°	1.7mm	28mm	28mm	20°	20°	55°	1.7mm	28mm	28mm	1.7mm	1.7mm		
Over Travel	OT(Min.)	30°	5.6mm	-	-	30°	30°	35°	6.4mm	-	-	5.6mm	5.6mm		
Movement Differential	MD(Max.)	12°	1mm	-	-	12°	12°	-	1mm	-	-	1mm	1mm		
Total Force	TF(Max.)	2720g	-	-	-	2720g	200g	-	-	-	-	2720g	2720g		
Total Travel	TT(Min.)	50°	6.5 ± 0.8mm	-	-	50°	50°	OP:90 ± 10°	OP:34 ± 2.8mm	-	-	6.5 ± 0.8mm	9 ± 0.8mm		

Appearance and Dimension

CWLCA2-2

Optional plastic idler wheel

CWLCA12-2-Q

Optional plastic idler wheel

CWLCL

CWLD

CWLD1

CWLD2

CWLD3

CWLCA12-2-QD

Appearance and Dimension

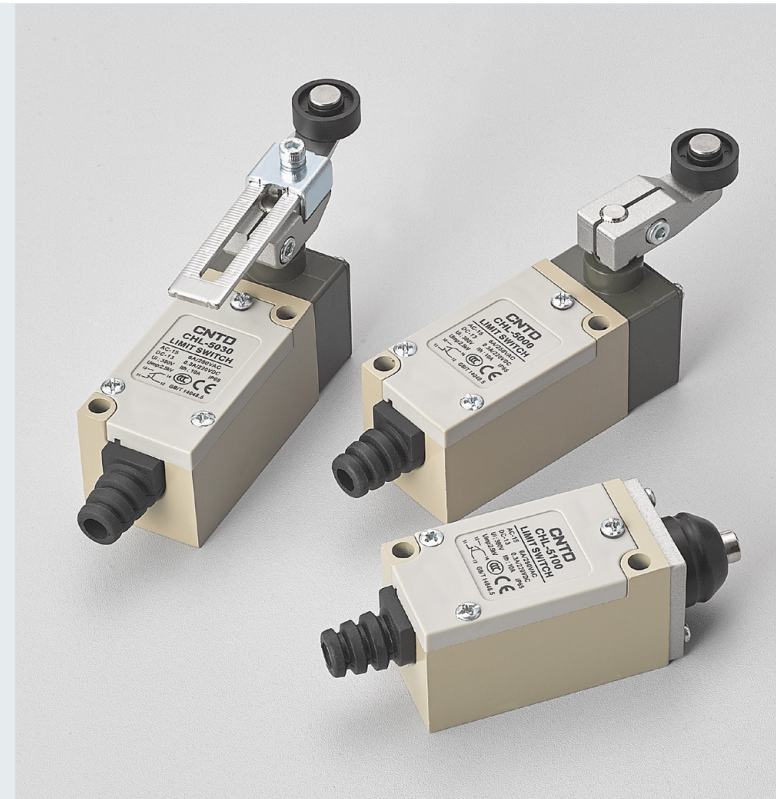
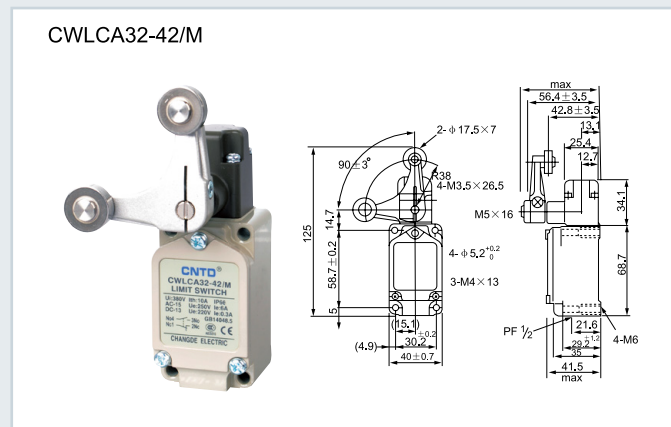
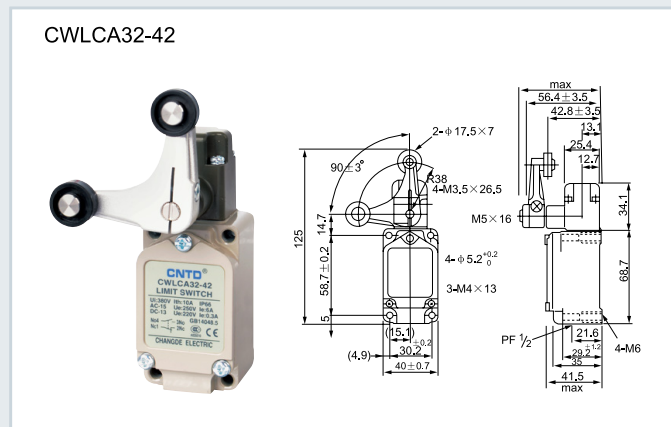
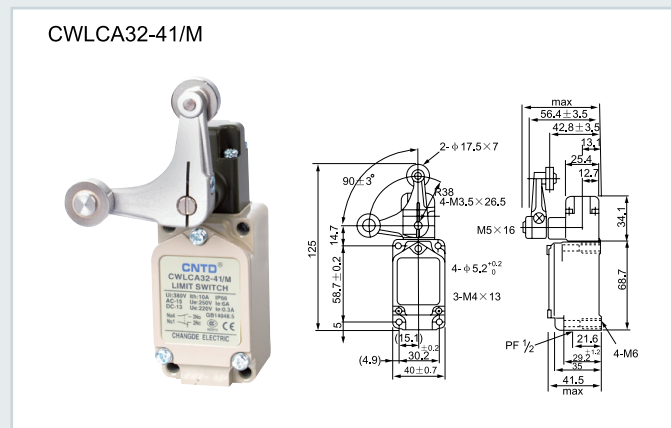
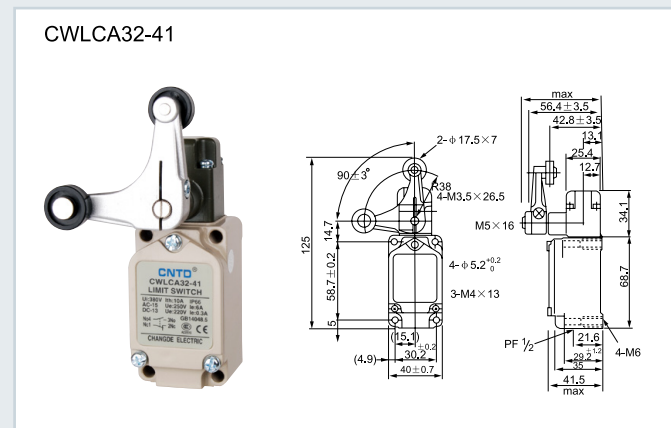
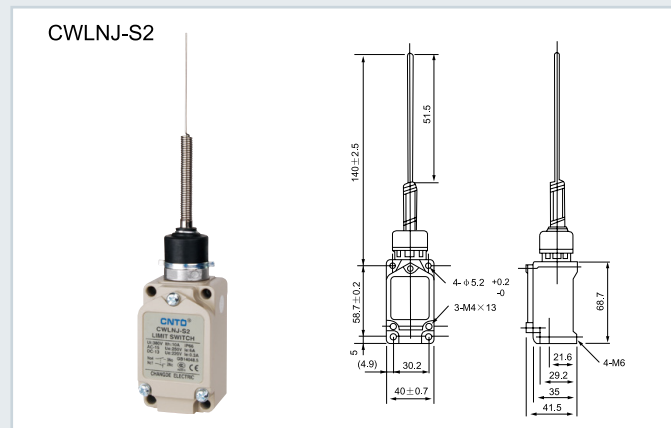
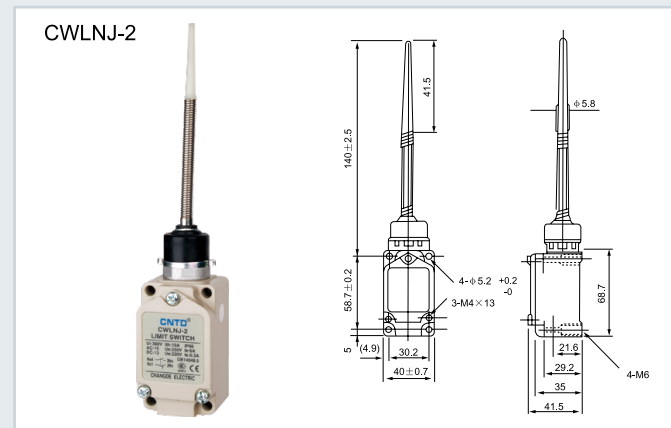
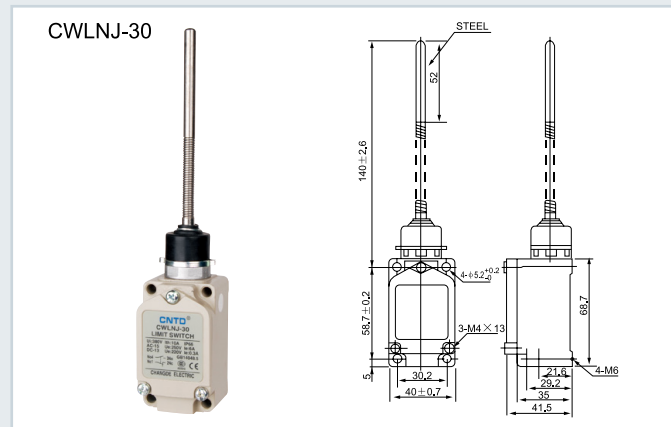
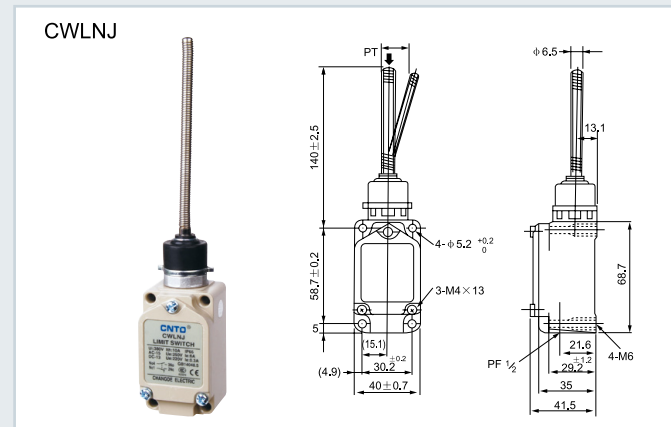

Features

- Various actuators for different applications
- Conduit design for convenient cabling
- Metal shell with high mechanical strength
- Built-in contact box has double-spring and long mechanical life

Contact Form

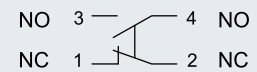

Ratings

Rated Voltage	Noninductive Load (A)				Inductive Load (A)			
	Resistance Load		Lamp Load		Inductive Load		Motor Load	
	NC	NO	NC	NO	NC	NO	NC	NO
125VAC	5	5	1.5	0.7	3	3	2	1
250VAC	5	5	1	0.5	3	3	1.5	0.8
8VDC	5	5	3	3	5	4	3	3
14VDC	5	5	3	3	4	4	3	3
30VDC	5	5	3	3	4	4	3	3
125VDC	0.4	0.4						
250VDC	0.2	0.2						
Inrush Current	N.C: below 24A, N.O: below 12A							

NOTES: 1. Inductive load has a power factor of 0.4 min.(AC) and a time constant of 7 msec. max.(DC).
 2. Lamp load has an inrush current of 10 times the steady-state current, while motor load has an inrush current of 6 times the steady-state current.
 3. Product with spring, its usable range of operating part is within one third of the whole spring length from the front end of spring.

Specifications

Operation speed	5mm-0.5m/s
Operating frequency	Electical: 30 operations/min
Contact resistance	25mΩ max. (initial value)
Insulation resistance	100mΩ min. (below 500VDC)
Dielectric strength	1000VAC, 50/60 Hz for 1 minute between terminals of the same polarity
	1500VAC, 50/60 Hz for 1 minute between current-carrying and non-current-carrying metal parts
	1500VAC, 50/60 Hz for 1 minute between each terminal and ground
Vibration	10-55Hz, 1.5mm double amplitude
Shock	Mechanical durable: 1,000m/Sec ² (about 100G'S) Malfunction: 300m/Sec ² (about 30G'S)
Ambient temperature	Using: -20~+70°C (With no icing)
Humidity	<95% RH
Electrical life	500,000 operations above
Protection level	IP65

Operating Characteristics

Model	CHL	CHL-5000	CHL-5030	CHL-5050	CHL-5100	CHL-5200	CHL-5220	CHL-5300	CHL-5330	CHL-5381	CHL-5391
Operating force	OF (Max.)	750g	750g	750g	750g	900g	900g	150g	150g	150g	550g
Release force	RF (Min.)	100g	100g	100g	200g	200g	200g	30g	30g	30g	100g
Pre-travel	PT (Max.)	20°	20°	20°	1.8mm	1.8mm	1.8mm	30mm	30mm	30mm	20°
Tripping position	TP ± 10%	22.5°	22.5°	22.5°	2.0mm	2.0mm	2.0mm	22.5°	22.5°	22.5°	22.5°
Movement differential	MD (Max.)	10°	10°	10°	1.2mm	1.2mm	1.2mm	14°	14°	14°	14°
Over travel	OT (Min.)	75°	75°	75°	4.0mm	4.0mm	4.0mm	20mm	20mm	20mm	75°
Total travel	TT (Min.)	95°	95°	95°	5.8mm	5.8mm	5.8mm	50mm	50mm	50mm	95°

Appearance and Dimension

CHL-5000

Optional metal idler wheel
Nylon Roller LSN-5000P

CHL-5220

Direction of rotor CHL-5220

CHL-5030

Optional metal idler wheel

CHL-5300

CHL-5050

CHL-5330

CHL-5100

CHL-5381

CHL-5200

Direction of rotor CHL-5220

CHL-5391



Features

- Double circuit type of limit switch
- High mechanical strength, consists of intensive plastic and aluminum cast
- Water-proof and oil proof construction
- Built-in contact box has double-spring and long mechanical life
- Smooth operation with larger over travel distance
- Various actuators for different application

Contact Form

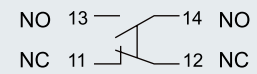

Ratings

Rated Voltage	Noninductive Load (A)				Inductive Load (A)			
	Resistance Load		Lamp Load		Inductive Load		Motor Load	
	NC	NO	NC	NO	NC	NO	NC	NO
125VAC	5	5	1.5	0.7	3	3	2	1
250VAC	5	5	1	0.5	3	3	1.5	0.8
8VDC	5	5	3	3	5	4	3	3
14VDC	5	5	3	3	4	4	3	3
30VDC	5	5	3	3	4	4	3	3
125VDC	0.4	0.4						
250VDC	0.2	0.2						
Inrush Current	N.C: below 24A, N.O: below 12A							

NOTES: 1. Inductive load has a power factor of 0.4 min.(AC) and a time constant of 7 msec. max.(DC).
 2. Lamp load has an inrush current of 10 times the steady-state current, while motor load has an inrush current of 6 times the steady-state current.
 3. Product with spring, its usable range of operating part is within one third of the whole spring length from the front end of spring.

Specifications

Operation speed	5mm-0.5m/s
Operating frequency	Electical: 30 operations/min
Contact resistance	25mΩ max. (initial value)
Insulation resistance	100mΩ min. (below 500VDC)
Dielectric strength	1500VAC, 50/60 Hz for 1 minute between current-carrying and non-current-carrying metal parts
	1500VAC, 50/60 Hz for 1 minute between each terminal and ground
Vibration	10-55Hz, 1.5mm double amplitude
Shock	Mechanical durable: 1,000m/Sec ² (about 100G'S)
	Malfunction: 300m/Sec ² (about 30G'S)
Ambient temperature	Using: -20~+70°C (With no icing)
Humidity	<95% RH
Electrical life	500,000 operations above
Protection level	IP66

NOTES: The default size of conduit connector is M18x1.5. Conduit connector size is PG11.5, with product model number plus (-P), example: CSA-012-P.

Operating Characteristics

Model	CSA	CSA-001	CSA-003	CSA-012	CSA-021 CSA-021M	CSA-041	CSA-031 CSA-031M	CSA-051	CSA-061	CSA-071	CSA-081
Operating force	OF (Max.)	800g	800g	800g	400g	400g	400g	400g	150g	150g	150g
Release force	RF (Min.)	400g	400g	400g	100g	100g	100g	100g	50g	50g	50g
Pre-travel	PT (Max.)	1.8mm	1.8mm	1.8mm	20°	20°	20°	20°	30mm	30mm	30mm
Tripping position	TP ± 10%	2.0mm	2.0mm	2.0mm	22.5°	22.5°	22.5°	22.5°	22.5°	22.5°	22.5°
Movement differential	MD (Max.)	1.2mm	1.2mm	1.2mm	10°	10°	10°	10°	14°	14°	14°
Over travel	OT (Min.)	4.0mm	4.0mm	4.0mm	75°	75°	75°	75°	20mm	20mm	20mm
Total travel	TT (Min.)	5.8mm	5.8mm	5.8mm	95°	95°	95°	95°	50mm	50mm	50mm
Rotary indexing					22.5°	22.5°	22.5°	22.5°			

Appearance and Dimension

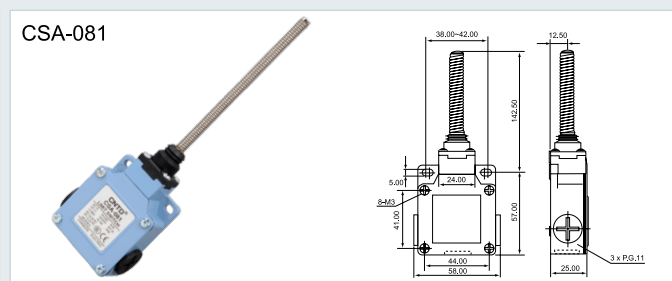
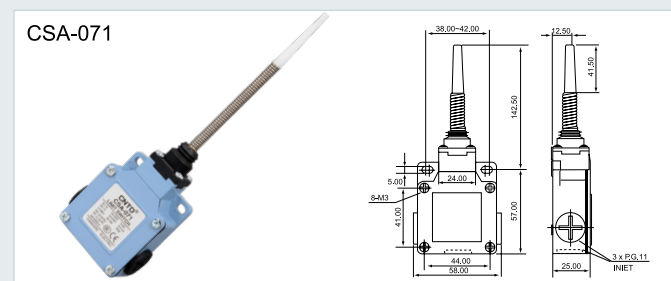
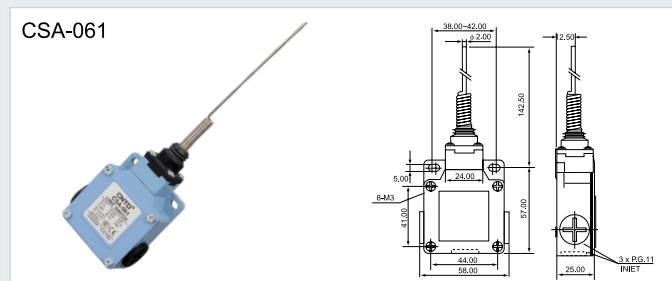
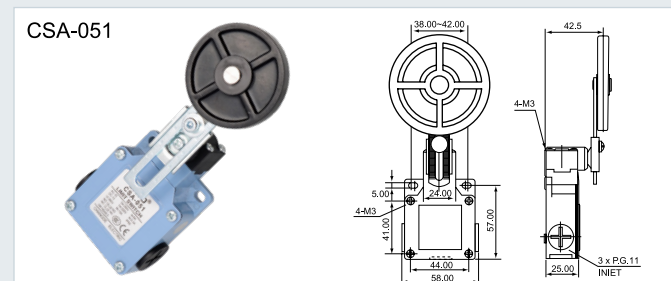
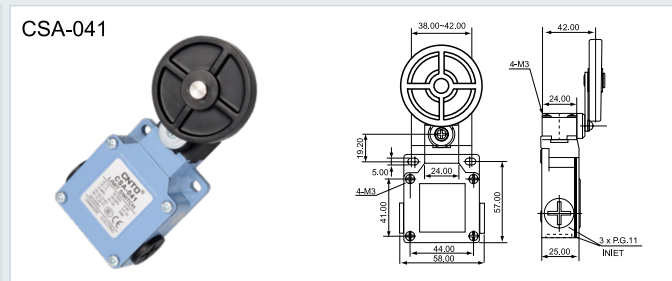
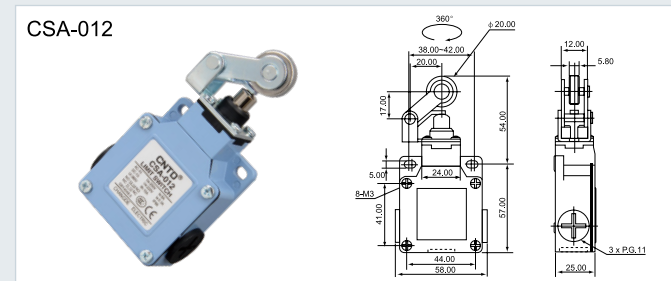
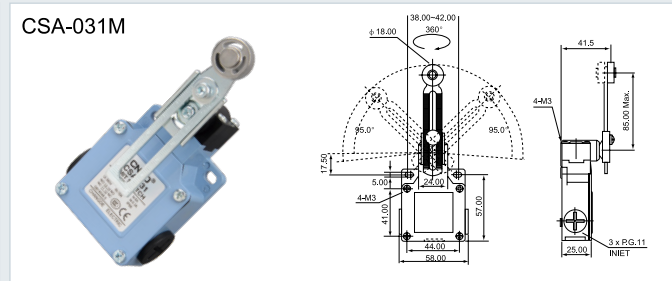
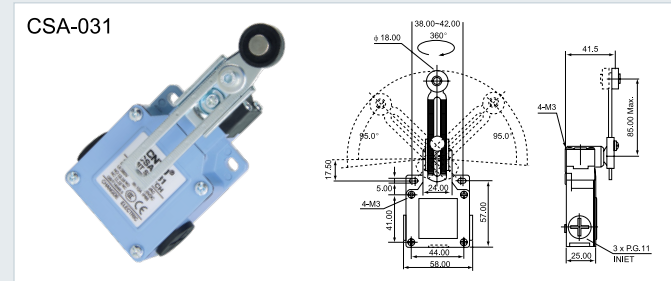
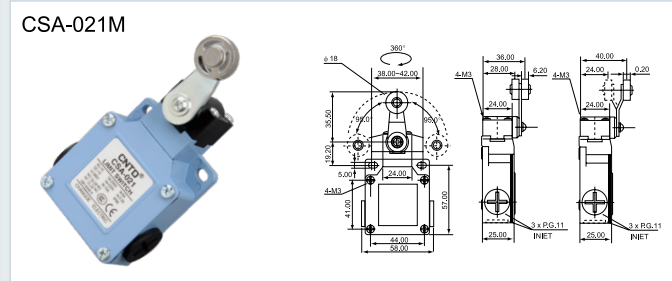
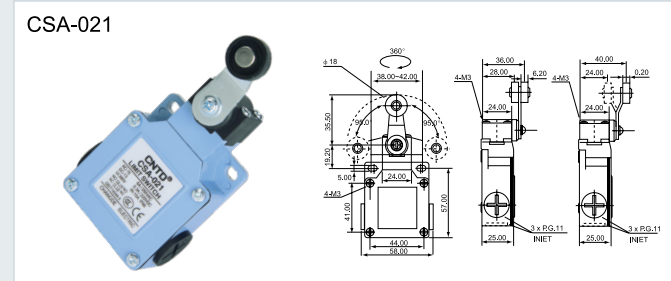
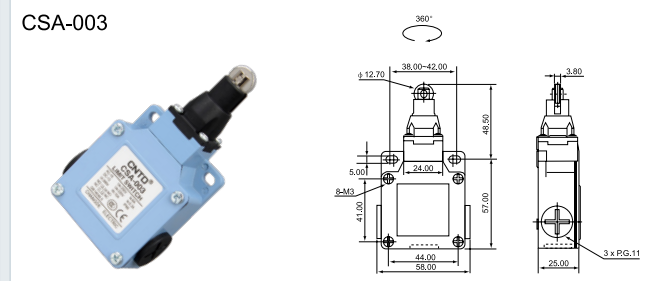
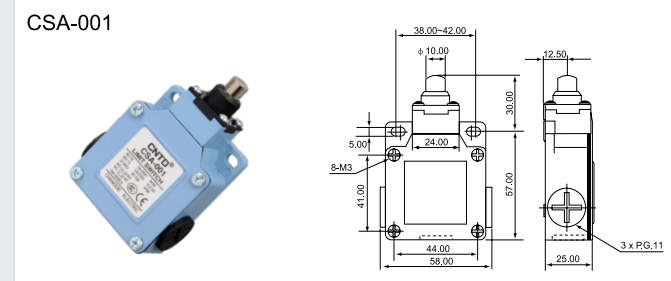

Features

- Double circuit type of limit switch
- Economic plastic type of limit switch
- Small size, water-proof and oil-proof construction
- Built-in contact box has double-spring and long mechanical life
- Smooth operation with larger over travel distance
- Various actuators for different applications

Contact Form

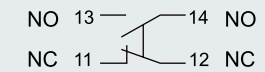

Ratings

Rated Voltage	Noninductive Load (A)				Inductive Load (A)			
	Resistance Load		Lamp Load		Inductive Load		Motor Load	
	NC	NO	NC	NO	NC	NO	NC	NO
125VAC	5	5	1.5	0.7	3	3	2	1
250VAC	5	5	1	0.5	3	3	1.5	0.8
8VDC	5	5	3	3	5	4	3	3
14VDC	5	5	3	3	4	4	3	3
30VDC	5	5	3	3	4	4	3	3
125VDC	0.4	0.4						
250VDC	0.2	0.2						
Inrush Current	N.C: below 24A, N.O: below 12A							

NOTES: 1. Inductive load has a power factor of 0.4 min.(AC) and a time constant of 7 msec. max.(DC).
 2. Lamp load has an inrush current of 10 times the steady-state current, while motor load has an inrush current of 6 times the steady-state current.
 3. Product with spring, its usable range of operating part is within one third of the whole spring length from the front end of spring.

Specifications

Operation speed	5mm-0.5m/s
Operating frequency	Electical: 30 operations/min
Contact resistance	25mΩ max. (initial value)
Insulation resistance	100mΩ min. (below 500VDC)
Dielectric strength	1500VAC, 50/60 Hz for 1 minute between current-carrying and non-current-carrying metal parts
	1500VAC, 50/60 Hz for 1 minute between current-carrying and non-current-carrying metal parts
	1500VAC, 50/60 Hz for 1 minute between each terminal and ground
Vibration	10-55Hz, 1.5mm double amplitude
Shock	Mechanical durable: 1,000m/Sec ² (about 100G'S) Malfunction: 300m/Sec ² (about 30G'S)
Ambient temperature	Using: -20~+70°C (With no icing)
Humidity	<95% RH
Electrical life	500,000 operations above
Protection level	IP66

NOTES: The default size of conduit connector is M20x1.5, outfitting cable connector. Conduit connector size is PG13.5, with product model number plus (-P), example:CLS-103-P.

Operating Characteristics

Model	CLS	101 301	102/103 302/303	111 311	121/121M 321/321M	127 327	131/131M 331/331M	161 361	171 371	181 381	191 391
Operating force	OF (Max.)	700g	700g	700g	500g	700g	500g	100g	100g	100g	500g
Release force	RF (Min.)	200g	200g	200g	100g	200g	100g	40g	40g	40g	100g
Pre-travel	PT (Max.)	1.8mm	1.8mm	1.8mm	20°	1.8mm	20°	30mm	30mm	30mm	20°
Tripping position	TP ± 10%	2.0mm	2.0mm	2.0mm	22.5°	2.0mm	22.5°	22.5°	22.5°	22.5°	22.5°
Movement differential	MD(Max.)	1.2mm	1.2mm	1.2mm	10°	1.2mm	10°	14°	14°	14°	10°
Over travel	OT (Min.)	4.0mm	4.0mm	4.0mm	75°	4.0mm	75°	20mm	20mm	20mm	75°
Total travel	TT (Min.)	5.8mm	5.8mm	5.8mm	95°	5.8mm	95°	50mm	50mm	50mm	95°
Rotary indexing					22.5°		22.5°				22.5°

CLS-1 Vertical Limit Switch



Appearance and Dimension

<p>CLS-101</p>	<p>CLS-102</p>
<p>CLS-103</p>	<p>CLS-111</p>
<p>CLS-112</p>	<p>CLS-127</p>
<p>CLS-121</p>	<p>CLS-121M</p>
<p>CLS-131</p>	<p>CLS-131M</p>

CLS-1 Vertical Limit Switch

Appearance and Dimension

<p>CLS-161</p>	<p>CLS-171</p>
<p>CLS-181</p>	<p>CLS-191</p>

CLS-3 Vertical Limit Switch

Appearance and Dimension

<p>CLS-301</p>	<p>CLS-302</p>
<p>CLS-303</p>	<p>CLS-311</p>

Appearance and Dimension

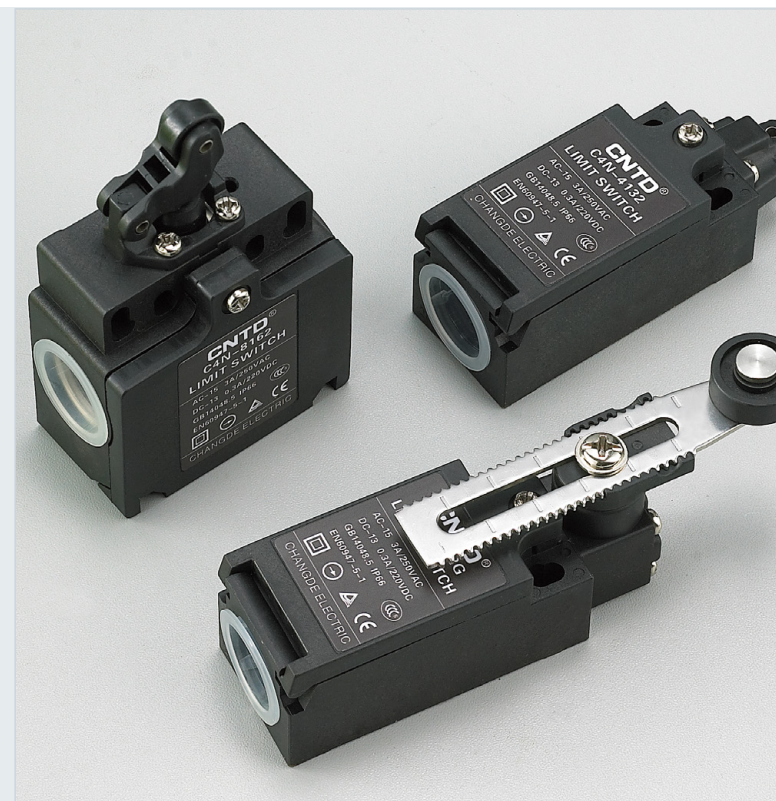
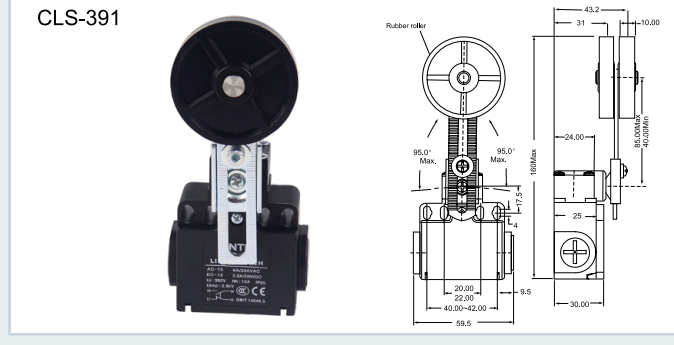
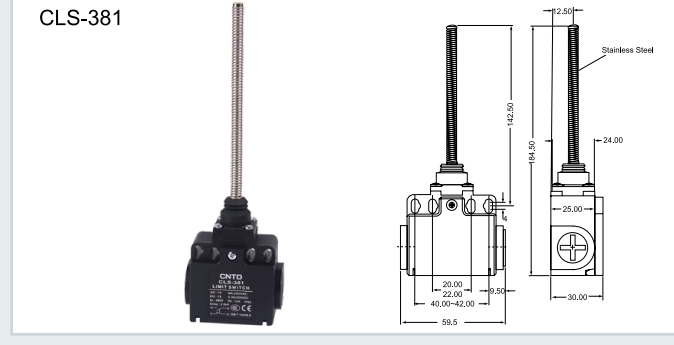
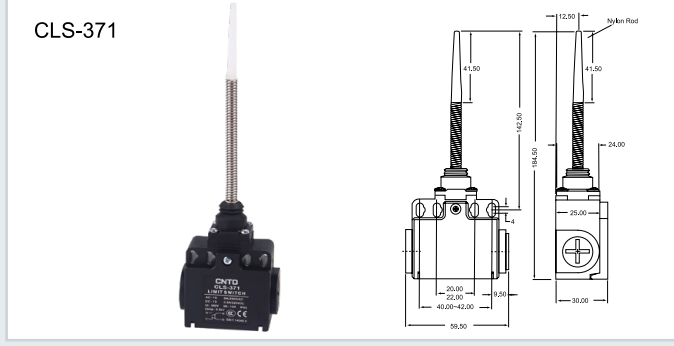
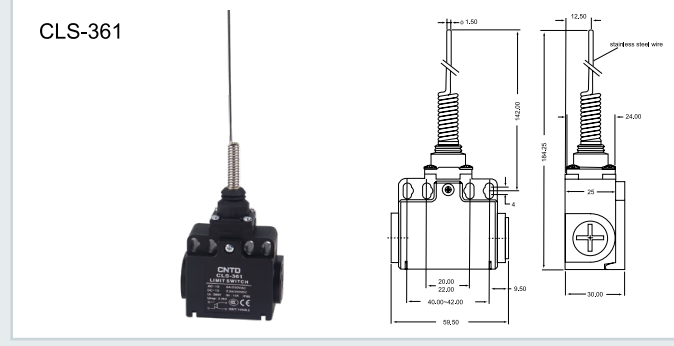
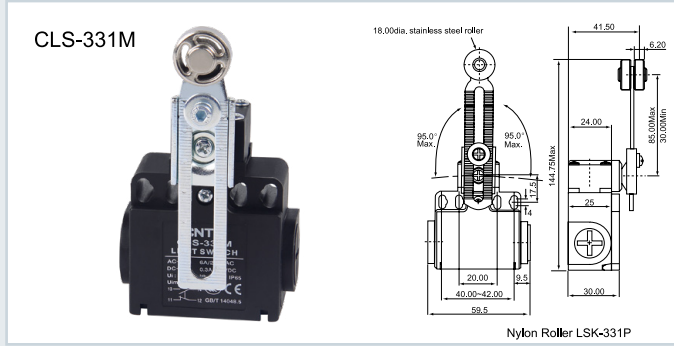
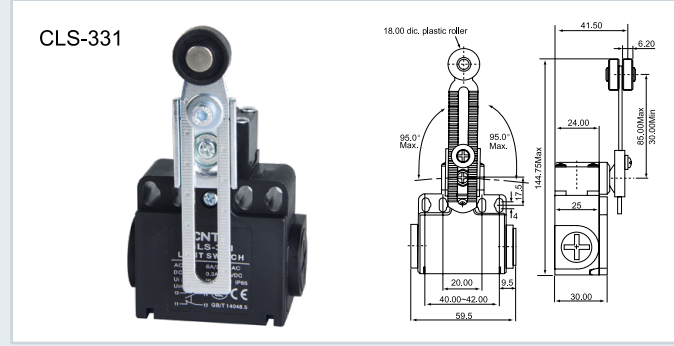
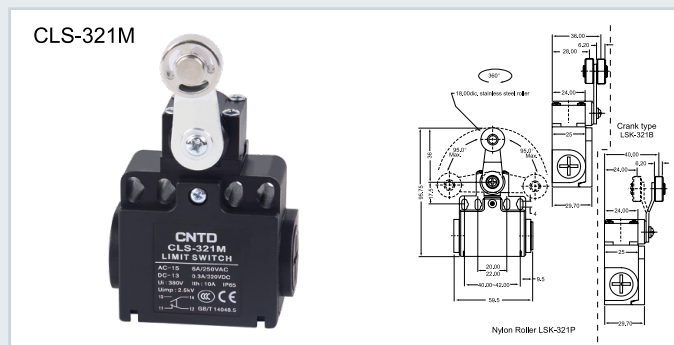
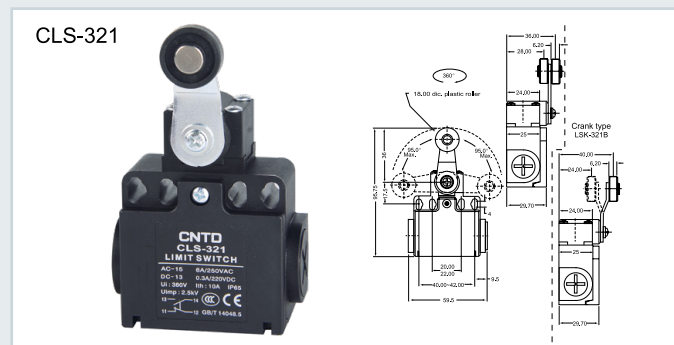
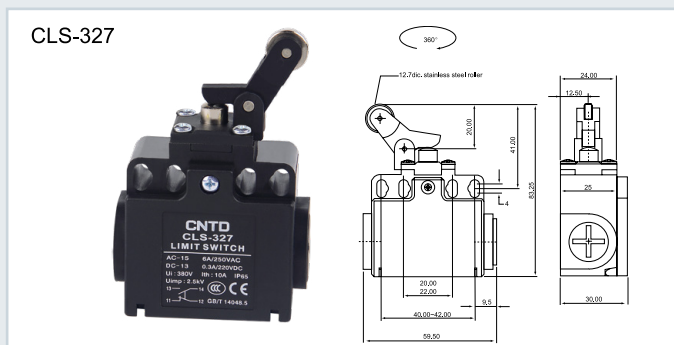
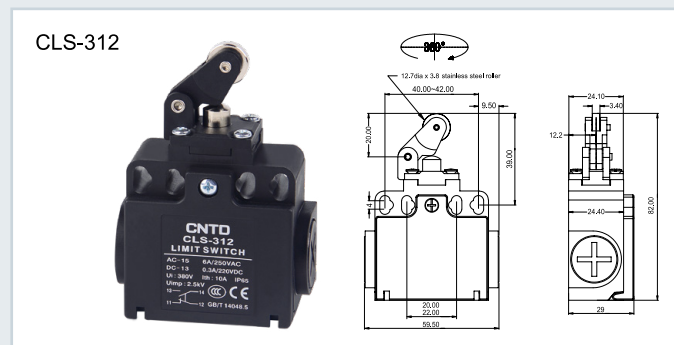

Features

- Forced open action device (NC contacts only), to disconnect the contact when the contact has fusing and other failures
- Strengthened top seal structure improves the sealing performance
- Built-in contact holder has fast-action type: 1NC/1NO; Slow-action: 1NC/1NO and 2NC

Model Number Structure

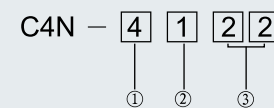

Item	Code	Description
① Conduit / connector size	1	Pg13.5 (1 conduit type)
	4	M20 (1 conduit type)
	5	Pg13.5 (2 conduits type)
	8	M20 (2 conduits type)
② Built-in switch	1	1NC/1NO (quick-action type)
	2	2NC (quick-action type)
	A	1NC/1NO (slow-action type)
	B	2NC (slow-action type)
③ Head and driving rod	20	Roller lever (resin lever, resin ball)
	22	Roller lever (metal lever, resin ball)
	25	Roller lever (metal lever, metal resin ball)
	2G	Adjustable roller lever, Form Lock (metal lever, resin ball)
	2H	Adjustable roller lever, Form Lock (metal lever, rubber ball)
	2M	Adjustable roller lever, Form Lock (metal lever, metal resin ball)
	31	Top plunger type
	32	Top plunger ball type
	62	Unilateral cantilever ball type (horizontal)
	72	Unilateral cantilever ball type (vertical)
	80	Whisker type
87	Plastic stick type	

NOTE: The default size of conduit connector is M20x1.5.

Specifications

Protection level	IP66	
Life	Electrical	More than 500,000 times (AC250V 3A, resistive load) More than 300,000 times (AC250V 10A, resistive load)
Operating speed	1mm-0.5m/s (C4N-4120)	
Operating frequency	Electrical: 30 operations/min	
Contact resistance	25 mΩ or less	
Minimum working load	1mA resistive load below DC5V (N standard reference value)	
Rated insulation voltage (Ui)	300V	
Electric shock protection grade	Class II (double insulated)	
Pollution degree (Using conditions)	Pollution degree 3 (EN60947-5-1)	
Withstand voltage (EN60947-5-1)	Between homopolar terminals: 2.5kV	
	Between heteropolar terminals: 2.5kV	
Insulation resistance	Between terminals and uncharged metal parts: 6kV	
	Above 100MΩ	
Contact gap		
Minimum 2 × 0.5mm quick-action type, Minimum 2 × 2mm slow-action type		
Vibration	Malfunction	10 ~ 55Hz 0.75mm single amplitude
	Duration	1,000m/s ²
Impact	Malfunction	300m/s ²
	Duration	1,000m/s ²
Ambient temperature	Using: -20~+70°C (With no icing)	
Ambient humidity	Less than 95% RH	
Weight	About 82g (D4N-1120)	
	About 99g (D4N-5120)	

Note 1. The above values are initial values.
 Note 2. Once the contact is connected to a standard load, it can not be used to connect a smaller load. If so, the contact may result in rough surface, thus losing contact reliability.
 *1. The protection level is gotten based on test method of (EN60947-5-1). Please make sure its sealing under actual environmental conditions before use. The switch box has dust and oil resistance structure, but it should be used in places without dust, oil and chemicals. Otherwise it may lead to premature wear, damage or malfunction.
 *2. The durability is for ambient temperature of 5°C ~ 35°C and humidity of 40% to 70% RH. For additional details, please contact us.
 *3. When the ambient temperature is above 35°C, more than 2 circuits 3A 250VAC loads are prohibited.
 *4. The values will vary with different switching frequency, environmental conditions, reliability level and other factors. Please confirm on the actual load in advance.



Forced Disconnecting Mechanism

■ 1NC and 1NO contacts (quick-action type)

■ 1NC and 1NO contacts (slow-action type)

■ 2NC contacts (slow-action type)

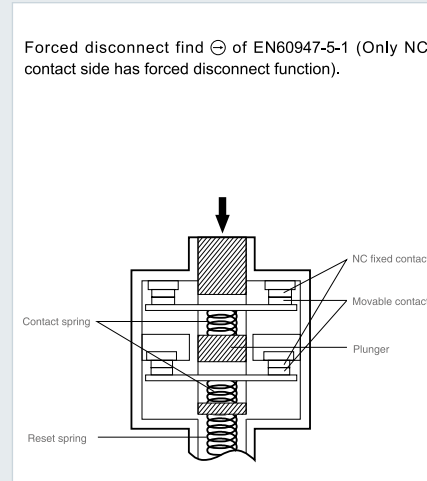
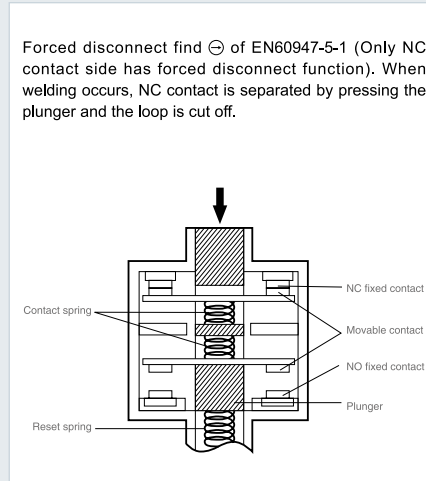
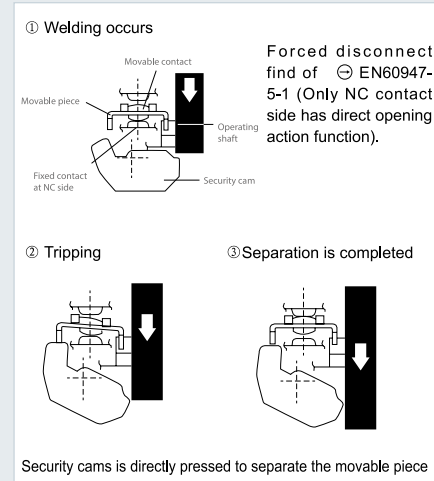

Contact Form

Model	Contact	Contact form	Operation mode	Explanation
C4N-□1□	1NC/1NO (Quick-action type)			Only NC contact (31-32) has forced disconnect function (⊖). Contacts (13-14) and (31-32) can be used as heteropoles.
C4N-□2□	2NC (Quick-action type)			Only NC contact (31-32) has forced disconnect function (⊖). Contacts (11-12) and (31-32) can be used as heteropoles.
C4N-□A□	1NC/1NO (Slow-action type)			Only NC contact (11-12) has forced disconnect function (⊖). Contacts (11-12) and (33-34) can be used as heteropoles.
C4N-□B□	2NC (Slow-action type)			Only NC contact (31-32) has forced disconnect function (⊖). Contacts (11-12) and (31-32) can be used as heteropoles.

Operating Characteristics

■ Quick-action type (1NC/1NO)(2NC), slow-action type (2NC)

Action characteristics	Model	Model										
		C4N-□120	C4N-□122	C4N-□125	C4N-□226	C4N-□131	C4N-□132	C4N-□162	C4N-□172	C4N-□12H	C4N-□12G	C4N-□□80
Action force	OF Max.	5.0N				6.5N	6.5N	5.0N	5.0N	4.5N	1.5N	1.5N
Restore force	RF Min.	0.5N				1.5N	1.5N	0.8N	0.8N	0.4N		
Pretravel	PT	18~27°				2mm	2mm	4mm	4mm	18 ~ 27°	15°	15°
Overtravel	OT Min.	40°				4mm	4mm	5mm	5mm	40°		
Poor response travel	MD Max.*1	14°				1mm	1mm	1.5mm	1.5mm	14°		
Action position	OP	—				18.2 ± 0.5mm	28.6 ± 0.8mm	37 ± 0.8mm	27 ± 0.8mm	—		
Total travel	TT *2	(80°)				(6mm)	(6mm)	(9mm)	(9mm)	(80°)		
Forced disconnected pretravel	DOT Min.*3	50°				3.2mm	3.2mm	5.8mm	4.8mm	50°		
Forced disconnected force	DOF Min.*3	20N				20N	20N	20N	20N	20N		

Note The simultaneity of ON / OFF operation of 2NC contacts have difference, please make sure before using it.
 *1. Only for quick-action type.
 *2. Reference values.
 *3. Only for slow-action type. For safe use, please make sure that all values are within the range of maximum or minimum.
 *4. The property value when length of lever is 32mm.

Operating Characteristics

■ Slow-action type (1NC/1NO)

Action characteristics	Model	Model										
		C4N-□A20	C4N-□A22	C4N-□A25	C4N-□A26	C4N-□A31	C4N-□A32	C4N-□A62	C4N-□A72	C4N-□A2H	C4N-□A2G *8	
Action force	OF Max.	5.0N				6.5N	6.5N	5.0N	5.0N	4.5N		
Restore force	RF Min.	0.5N				1.5N	1.5N	0.8N	0.8N	0.4N		
Pretravel	PT *1	18 ~ 27°				2mm	2mm	4mm	4mm	18 ~ 27°		
	PT (2nd)*2	(44°)				(2.9mm)	(2.9mm)	(5.2mm)	(4.3mm)	(44°)		
	PT *3	27.5 ~ 36.5°				2.8mm	2.8mm	4mm	4mm	27.5 ~ 36.5°		
	PT (2nd)*4	(18°)				(1mm)	(1mm)	(1.5mm)	(1.5mm)	(18°)		
Overtravel	OT Min.	40°				4mm	4mm	5mm	5mm	40°		
Action position	OP	—				18.2 ± 0.5mm	28.6 ± 0.8mm	37 ± 0.8mm	27 ± 0.8mm	—		
	OP *5	—				17.4 ± 0.5mm	28 ± 0.8mm	36 ± 0.8mm	26.1 ± 0.8mm	—		
Total travel	TT *6	(80°)				(6mm)	(6mm)	(9mm)	(9mm)	(80°)		
Forced disconnected pretravel	DOT Min.*7	50°				3.2mm	3.2mm	5.8mm	4.8mm	50°		
Forced disconnected force	DOF Min.*7	20N				20N	20N	20N	20N	20N		

*1. NC contact is open.
 *2. NO contact is closed.
 *3. Only for MBB type.
 *4. It is the reference value of MBB type.
 *5. Only for MBB type.
 *6. Reference values
 *7. For safe use, please make sure that all values are within the range of maximum or minimum.
 *8. The property value when length of lever is 32mm.

Appearance and Dimension

C4N-4131

C4N-4132

C4N-4162

C4N-4172



Appearance and Dimension

C4N-4120

C4N-4122

C4N-412M

C4N-4125

C4N-412G

C4N-412H

C4N-4180

C4N-4187

C4N-8131

C4N-8132

Appearance and Dimension

C4N-8162

C4N-8172

C4N-8120

C4N-8122

C4N-812M

C4N-8125

C4N-812G

C4N-812H

C4N-8180

C4N-8187

* Application of stainless steel washers and plastic stick are within 35mm from the front end, the entire action is within 70mm.

* Use of application of stainless steel washers and plastic stick are within 35mm from the front end, the entire action is within 70mm

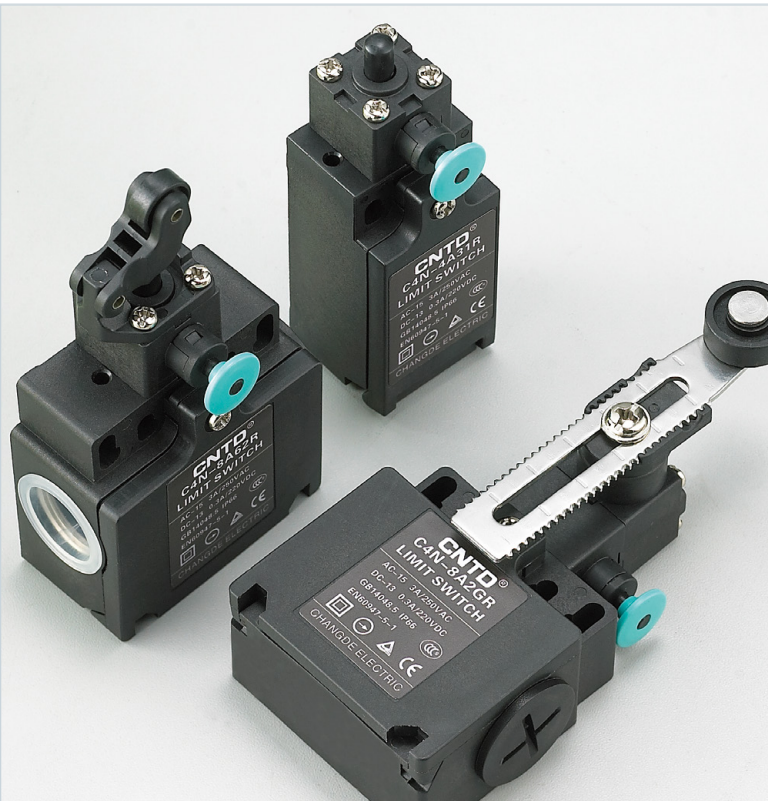

Model Number Structure

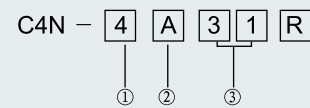

Item	Code	Description
① Conduit / connector size	1	Pg13.5 (1 conduit type)
	4	M20 (1 conduit type)
	5	Pg13.5 (2 conduits type)
	8	M20 (2 conduits type)
② Built-in switch	A	1NC/1NO (slow-action type)
	B	2NC (slow-action type)
③ Head and driving rod	20	Roller lever (resin lever, resin ball)
	22	Roller lever (metal lever, resin ball)
	25	Roller lever (metal lever, metal resin ball)
	2G	Adjustable roller lever, Form Lock (metal lever, resin ball)
	2H	Adjustable roller lever, Form Lock (metal lever, rubber ball)
	2M	Adjustable roller lever, Form Lock (metal lever, metal resin ball)
	31	Top plunger type
	32	Top plunger ball type
	62	Unilateral cantilever ball type (horizontal)
	72	Unilateral cantilever ball type (vertical)

NOTE: The default size of conduit connector is M20x1.5.

Features

- Forced open action device (NC contacts only), to disconnect the contact when the contact has fusing and other failures
- Strengthened top seal structure improves the sealing performance
- Built-in contact holder has slow-action: 1NC /1NO and 2NC

Specifications

Protection level	IP66	
Life	Electrical	More than 500,000 times (AC250V 3A, resistive load) More than 300,000 times (AC250V 10A, resistive load)
	Operating speed	1mm-0.5m/s (C4N-4A20R)
Operating frequency	Max. 30 times/min	
Contact resistance	25 mΩ or less	
Minimum working load	1mA resistive load below DC5V (N standard reference value)	
Rated insulation voltage (Ui)	300V	
Electric shock protection grade	Class II (double insulated)	
Pollution degree (Using conditions)		Pollution degree 3 (EN60947-5-1)
	Withstand voltage (EN60947-5-1)	Between homopolar terminals: 2.5kV Between heteropolar terminals: 2.5kV Between terminals and uncharged metal parts: 6kV
	Insulation resistance	Above 100MΩ
Contact gap	Minimum 2 × 0.5mm quick-action type, Minimum 2 × 2mm slow-action type	
Vibration	Malfunction	10 ~ 55Hz 0.75mm single amplitude
	Duration	1,000m/s ²
Impact	Malfunction	300m/s ²
	Ambient temperature	Using: -20~+70℃ (With no icing)
Ambient humidity	Less than 95% RH	
Weight	About 92g (D4N-1A20R)	

- Note 1. The above values are initial values.
 Note 2. Once the contact is connected to a standard load, it can not be used to connect a smaller load. If so, the contact may result in rough surface, thus losing contact reliability.
- *1. The protection level is gotten based on test method of (EN60947-5-1). Please make sure its sealing under actual environmental conditions before use. The switch box has dust and oil resistance structure, but it should be used in places without dust, oil and chemicals. Otherwise it may lead to premature wear, damage or malfunction.
 - *2. The durability is for ambient temperature of 5℃ ~ 35℃ and humidity of 40% to 70% RH. For additional details, please contact us.
 - *3. When the ambient temperature is above 35℃, more than 2 circuits 3A 250VAC loads are prohibited.
 - *4. The values will vary with different switching frequency, environmental conditions, reliability level and other factors. Please confirm on the actual load in advance.

Forced Disconnecting Mechanism

- 1NC and 1NO contacts (slow-action type)

Only NC contact has forced disconnect structure. When melting occurs, the contact can be isolated by pressing the plunger to cut off the loop. (In accordance with EN60947-5-1 force disconnect operation).

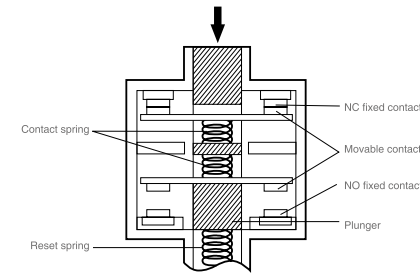

- 2NC contacts (slow-action type)

When melting occurs, the contact can be isolated by pressing the plunger to cut off the loop. (In accordance with EN60947-5-1 force disconnect operation).

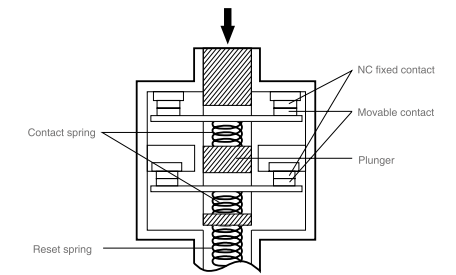

Contact Form

Model	Contact	Contact form	Operation mode	Explanation
C4N-□A□R	1NC/1NO (Slow-action type)			Only NC contact (11-12) has forced disconnect function (⊖). Contacts (11-12) and (33-34) can be used as heteropoles.
C4N-□B□R	2NC (Slow-action type)			Only NC contact (31-32) has forced disconnect function (⊖). Contacts (11-12) and (31-32) can be used as heteropoles.

Operating Characteristics

Model		C4N-□□20R	C4N-□□22R	C4N-□□2GR*2	C4N-□□2HR	C4N-□□31R	C4N-□□32R	C4N-□□62R	C4N-□□72R
LF	Max.	6.45N	6.45N	5.6N	5.4N	10.8N	10.8N	7.5	7.9N
LT	Max.	55°	55°	55°	55°	4.5mm	4.5mm	7mm	7mm
PT1	*3	18~27°	18~27°	18~27°	18~27°	2mm	2mm	4mm	4mm
PT2	*4	(44°)	(44°)	(44°)	(44°)	(2.9mm)	(2.9mm)	(5.2mm)	(4.3mm)
OP		-	-	--	-	34 ± 0.5mm	44.4 ± 0.8mm	53 ± 0.8mm	27 ± 0.8mm
TT	*5	80°	80°	80°	80°	(6mm)	(6mm)	(9mm)	(9mm)
DOT	Min.*6	50°	50°	50°	50°	3.2mm	3.2mm	5.8mm	5.8mm
DOF	Min.*6	20N		20N	20N	20N	20N	20N	20N

Note

- *1. The simultaneity of ON / OFF operation of 2NC contacts have difference, please make sure before using it.
- *2. The property value when length of lever is 32mm.
- *3. PT value when NC contact is at open (OFF) state.
- *4. PT common value when NO contact is at close (ON) state (only for 1NC/1NO types).
- *5. Reference values.
- *6. Load and travel values of forced disconnect structure. To ensure safety, be sure to remain within the upper and lower range.

Appearance and Dimension

<p>C4N-4A31R</p>	<p>C4N-4A32R</p>
<p>C4N-4A62R</p>	<p>C4N-4A72R</p>
<p>C4N-4A20R</p>	<p>C4N-4A22R</p>
<p>C4N-4A2GR</p>	<p>C4N-4A25R</p>
<p>C4N-4A2MR</p>	<p>C4N-4A2HR</p>

Appearance and Dimension

<p>C4N-8A31R</p>	<p>C4N-8A32R</p>
<p>C4N-8A62R</p>	<p>C4N-8A72R</p>
<p>C4N-8A20R</p>	<p>C4N-8A22R</p>
<p>C4N-8A2MR</p>	<p>C4N-8A25R</p>
<p>C4N-8A2GR</p>	<p>C4N-8A2HR</p>



Features

- Forced open action device (NC contacts only), to disconnect the contact when the contact has fusing and other failures
- Strengthened top seal structure improves the sealing performance
- Built-in contact holder has fast-action type: 1NC / 1NO; Slow-action: 1NC / 1NO and 2NC

Model Number Structure

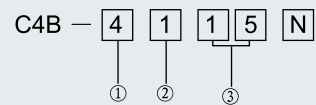

Item	Code	Description
① Conduit / connector size	1	Pg13.5 (1 conduit type)
	4	M20 (1 conduit type)
② Built-in switch	1	1NC/1NO (quick-action type)
	5	1NC/1NO (slow-action type)
	A	2NC (slow-action type)
③ Head and driving rod	11	Roller lever (resin lever, resin ball)
	12	Form-Lock Adjustable roller lever, Form-Lock (metal lever, metal ball)
	15	Roller lever (metal ball)
	16	Form-Lock Adjustable roller lever, Form-Lock (resin ball)
	17	Form-Lock Adjustable stick lever, Form-Lock (long lever)
	18	Form Lock Adjustable roller lever, Form Lock (metal lever, rubber ball)
	70	Top ball plunger type
	71	Ball plunger type
	72	Ball plunger type
	81	Coil spring type
	87	Plastic stick type
86	Metal stick type	

NOTE: The default size of conduit connector is M20x1.5.

Ratings

Rated voltage (V)	Non-inductive load (A)				Inductive load (A)			
	Resistive load		Lamp load		Inductive load		Motor load	
	NC	NO	NC	NO	NC	NO	NC	NO
AC	125	10		3	1.5		5	2.5
	250	10		2	1		3	1.5
	400	10		1.5	0.8		1.5	0.8
DC	8	10		6	3			6
	14	10		6	3			6
	30	6		4	3			4
	125	0.8		0.2	0.2			0.2
	250	0.4		0.1	0.1			0.1

Note1. The above values represent constant current.

2. The so-called inductive load refers to the load with power factor of 0.4 or more (AC) and the time constant below 7ms (DC).

3. The so-called lamp load refers to the load with 10 times of surge current.

4. The so-called motor load is the load with 6 times of surge current.

Specifications

Protection level	IP66	
Life	Electrical	More than 500,000 times (AC250V 10A, resistive load)
Operating speed	1mm~0.5m/s	
Operating frequency	Mechanical	120 times/min
	Electrical	30 times/min
Rated frequency	50/60Hz	
Insulation resistance	100MΩ or more (DC500V Megameter) between homopolars, and between terminals and uncharged metal parts	
Contact resistance	25mΩ or less (initial value)	
Withstand voltage (EN60947-5-1)	Between homopolar terminals: 2.5kV(quick-action type)/4kV(slow-action type)	
	Between heteropolar terminals: 2.5kV(slow-action type)	
	Between charged metal parts: 4kV	
	Between terminals and uncharged metal parts: 6kV	
Rated insulation voltage (Ui)	600V(EN60947-5-1)	
Reverse voltage when on/off	1500V max (EN60947-5-1)	
Pollution degree (environmental conditions)	Pollution degree 3 (EN60947-5-1)	
Electric shock protection grade	Class I (with ground terminal)	
Vibration	Malfunction	10 - 55Hz 0.75mm single amplitude
	Duration	1,000m/s ²
Impact	Malfunction	300m/s ²
	Duration	
Ambient temperature	Using: -20~+80 C (With no icing)	
Ambient humidity	Less than 95% RH	
Weight	About 250g	

Note 1. The above are initial values.

Note 2. Values of some models may be different from the above, please contact us for details.

*1. The protection structure is tested based on method predetermined by standard (EN69047-5-1), please confirm the sealing in advance according to the operating environment and conditions.

*2. The conditions of life are the values under the ambient temperature of 5~35°C and humidity of 40 to 70% RH. For other detailed conditions, please contact us.

Forced Disconnecting Mechanism

■ 1NC and 1NO contacts (quick-action type)

■ 1NC and 1NO contacts (slow-action type)

■ 2NC contacts (slow-action type)

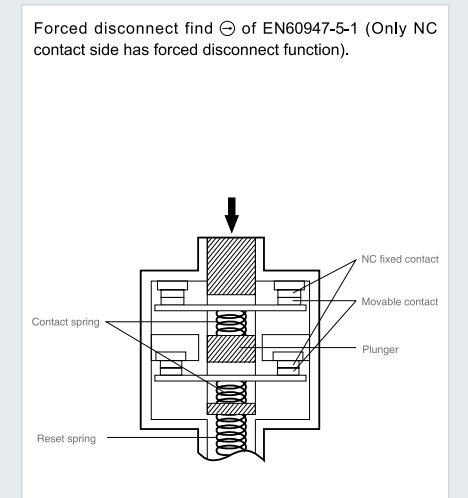
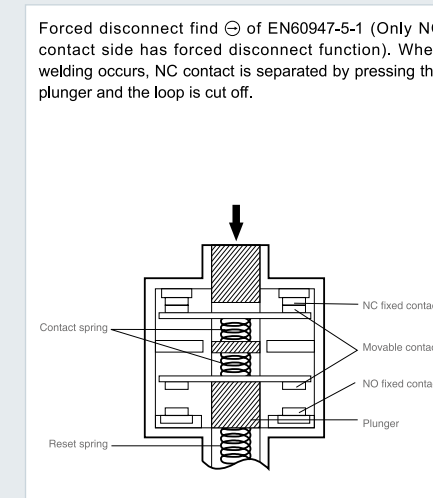
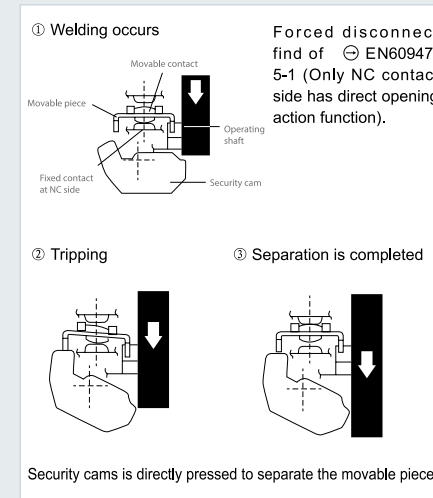



Contact form

Model	Contact	Contact form	Operation mode	Explanation
C4B-□1□N	1NC/1NO (Quick-action type)			Only NC contact (11-12) has forced disconnect function and got the certification (terminal No.11-12,13-14 can not be used as different heteropoles)
C4B-□5□N	1NC/1NO (Slow-action type)			Only NC contact (11-12) has forced disconnect function and got the certification (terminal No.11-12,13-14 can not be used as different heteropoles)
C4B-□A□N	2NC (Slow-action type)			Two NC contacts (11-12, 21-22) have forced disconnect function and got the certification (terminal No.11-12,21-22 can be used as different heteropoles)

Operating Characteristics

Model		C4B-□□11N	C4B-□□15N	C4B-□□16N *1	C4B-□□17N *2	C4B-□□18N *2	C4B-□□70N	C4B-□□71N	C4B-□□81N	C4B-□□86N	C4B-□□87N
Action characteristics											
Action force	OF Max.	9.41N	9.41N	9.41N	2.12N	9.41N	18.63N	18.63N	1.47N	1.47N	1.47N
Restore force	RF Min.	1.47N	1.47N	1.47N	0.29N	1.47N	1.96N	1.96N			
Pretravel	PT	21° ± 3°	21° ± 3°	21° ± 3°	21° ± 3°	21° ± 3°	2mm	2mm	15	15	15
	PT (2nd) *3 *5	(45°)	(45°)	(45°)	(45°)	(45°)	(3mm)	(3mm)			
Overtravel	OT Min.	50°	50°	50°	50°	50°	5mm	5mm			
Poor response travel	MD Max. *4	12°	12°	12°	12°	12°	1mm	1mm			
Forced disconnected pretravel	DOT Min. *3*6	35°	35°	35°	35°	35°	3.2mm	3.2mm			
		*4*6	55°	55°	55°	55°					
Forced disconnected force	DOF Min. *6	19.61N	19.61N	19.61N	19.61N	19.61N	49.03N	49.03N			
Total travel	TT *5	(75°)	(75°)	(75°)	(75°)	(75°)	(7mm)	(7mm)			
Free position	FP Max.						38mm	51mm			
Action position	OP						35 ± 1mm	48 ± 1mm			

Note The simultaneity of ON / OFF operation of 2NC contacts have difference, please make sure before using it.

- *1. The property value when length of lever is 31.5mm.
- *2. The property value when length of lever is 140mm.
- *3. Only for slow-action type.
- *4. Only for quick-action type.
- *5. Reference values.
- *6. Please make sure in order to ensure the safe use.

Appearance and Dimension

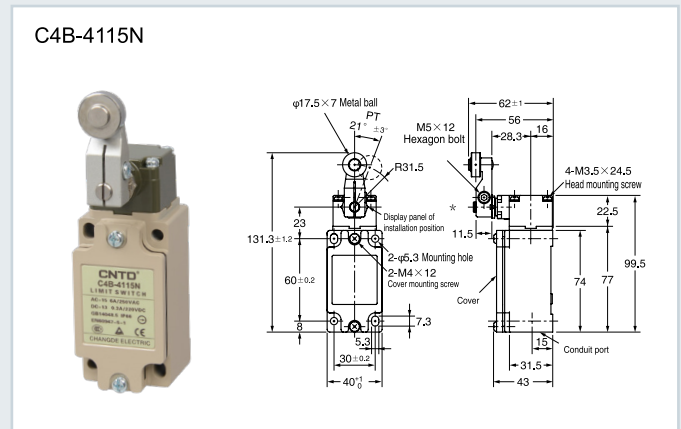
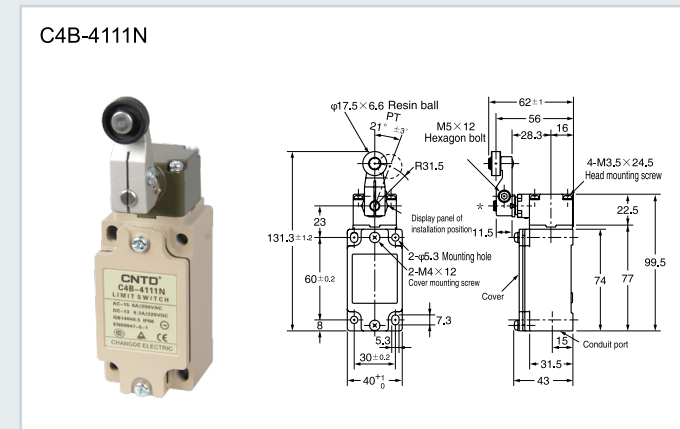

Appearance and Dimension

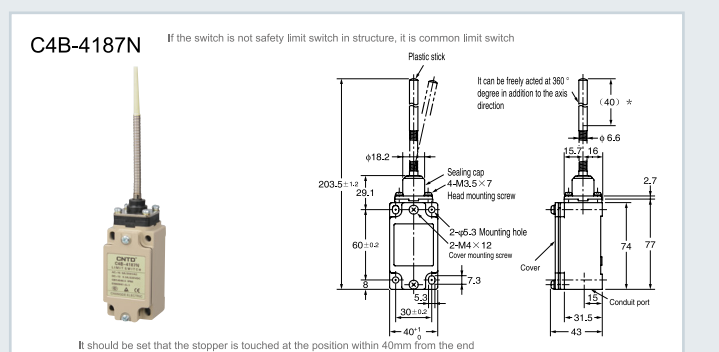
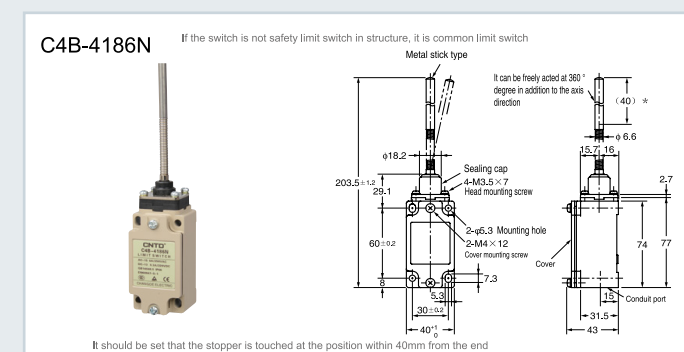
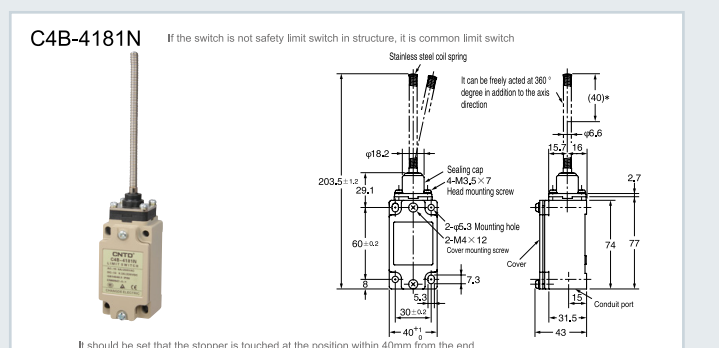
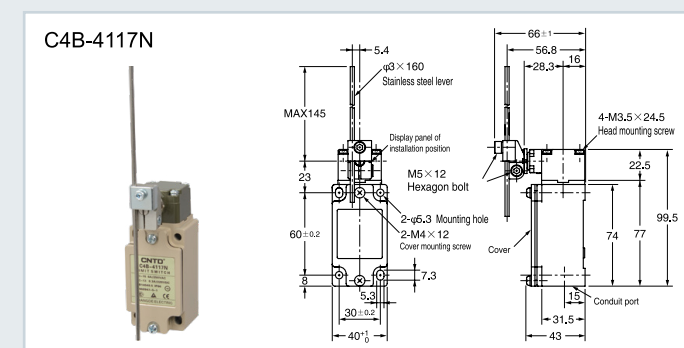
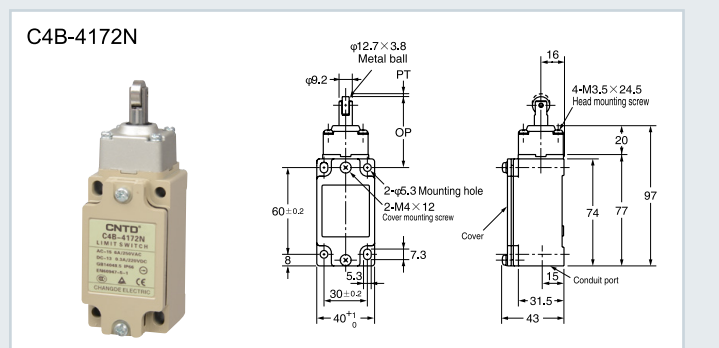
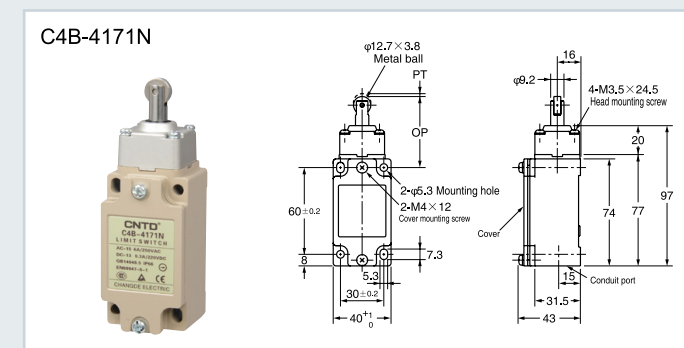
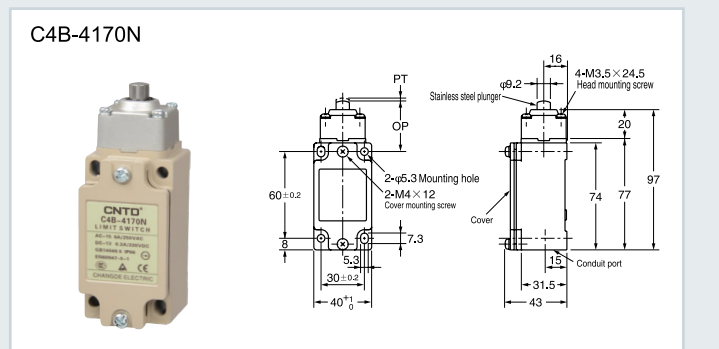
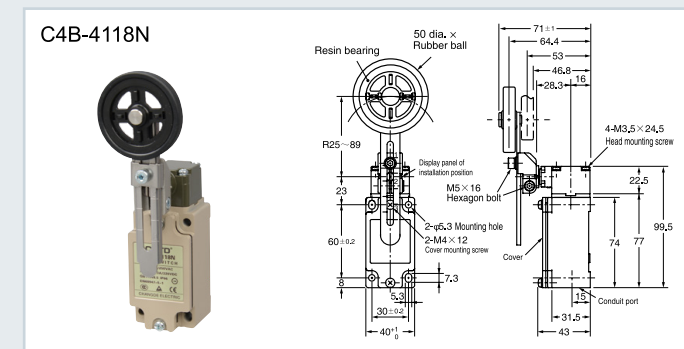
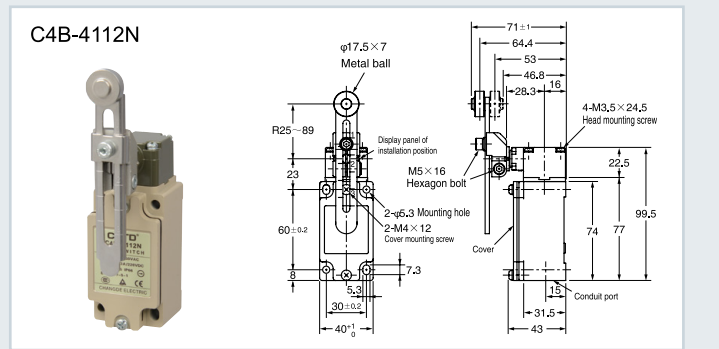
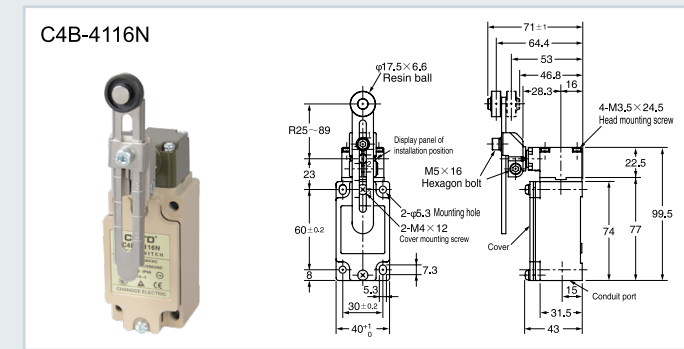

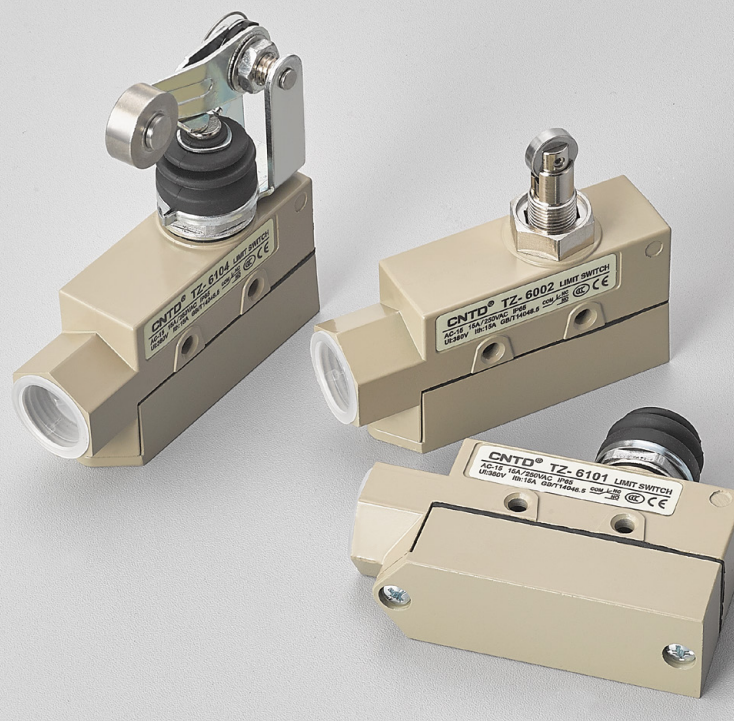

Features

- Built-in CM horizontal limit switch
- High mechanical strength, mainly consists of aluminum cast
- Water-proof and oil-proof construction
- Same rated value and characteristic with CM horizontal limit switch
- Various actuators for different applications

Contact Form

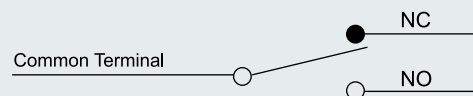

Ratings

Rated Voltage	Noninductive Load (A)				Inductive Load (A)			
	Resistance Load		Lamp Load		Inductive Load		Motor Load	
	NC	NO	NC	NO	NC	NO	NC	NO
125VAC	5	5	1.5	0.7	3	3	2	1
250VAC	5	5	1	0.5	3	3	1.5	0.8
8VDC	5	5	3	3	5	4	3	3
14VDC	5	5	3	3	4	4	3	3
30VDC	5	5	3	3	4	4	3	3
125VDC	0.4	0.4						
250VDC	0.2	0.2						
Inrush Current	N.C: below 24A, N.O: below 12A							

NOTES: 1. Inductive load has a power factor of 0.4 min.(AC) and a time constant of 7 msec. max.(DC).
 2. Lamp load has an inrush current of 10 times the steady-state current, while motor load has an inrush current of 6 times the steady-state current.
 3. Product with spring, its usable range of operating part is within one third of the whole spring length from the front end of spring.

Specifications

Operation speed	5mm-0.5m/s
Operating frequency	Electical: 20 operations/min
Contact resistance	25mΩ max. (initial value)
Insulation resistance	100mΩ min. (below 500VDC)
Dielectric strength	1500VAC, 50/60 Hz for 1 minute between current-carrying and non-current-carrying metal parts
	1500VAC, 50/60 Hz for 1 minute between each terminal and ground
Vibration	10-55Hz, 1.5mm double amplitude
Shock	Mechanical durable: 1,000m/Sec ² (about 100G'S) Malfunction: 300m/Sec ² (about 30G'S)
Ambient temperature	Using: -20~+80 C (With no icing)
Humidity	<95% RH
Electrical life	500,000 operations above
Protection level	IP66

NOTES: The default size of conduit connector is M20x1.5, outfitting cable connector. Conduit connector size is PG13.5, with product model number plus (-P), example: TZ-6104-P.

Operating Characteristics

Model	TZ-6	TZ-6001	TZ-6002	TZ-6003	TZ-6004	TZ-6043	TZ-6101	TZ-6102	TZ-6103	TZ-6104	TZ-6143
Operating force	OF(Max.)	250-350g	250-350g		570g	570g	800g	500g		640g	640g
Release force	RF(Min.)	114g	114g		170g	170g	240g	100g		230g	230g
Pre-travel	PT(Max.)	0.4mm	0.5mm		4mm	4mm	2mm	1mm		5mm	5mm
Movement differential	MD(Max.)	0.05mm	0.05mm		0.4mm	0.4mm	0.1mm	0.12mm		0.4mm	0.4mm
Over travel	OT(Min.)	5.5mm	3.6mm		6mm	6mm	5mm	3.5mm		6mm	6mm
Operating Position	OP(mm.)	38.2 ± 0.8mm	49.7 ± 1mm				45.8 ± 0.8mm	49.7 ± 0.8mm			

Appearance and Dimension

TZ-6001

TZ-6101

TZ-6002

TZ-6003

TZ-6102

TZ-6103

TZ-6004

TZ-6104

TZ-6143

TZ-6106



Model Number Structure

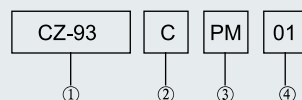

Designation	Model NO.	Description
Type	CZ-93	Safety switch
Type of contact blocks fitted	B	2B(2NC)
	C	1A1B(1NC/1NO)
Conduit/connector size	PG	PG 13.5XP1.5
	PM	M20X1.5
Actuating keys	None	None
	01	Horizontal
	02	90° Vertical
	03	Adjustable

NOTE: The default size of conduit connector is M20x1.5.

Specifications

Rating	3A 240VAC (A300)
Operating speed	0.1m-0.5m/s
Operating frequency	30 operations/min
Contact resistance	25mΩ max. (initial).
Insulation resistance	100mΩ min. (at 500VDC)
Rated insulation voltage(UI)	400V
Dielectric strength	AC2500V/Ump 4KV
Vibration	10 to 55Hz, 1.5mm double amplitude
Shock	Mechanical: Approx. 1000m/s ² (Approx. 100G'S) Electrical: Approx. 300m/s ² (Approx. 30G'S)
Ambient temperature	Using: -20~+70°C (With no icing)
Ambient Humidity	< 95% RH
Electrical life	150,000 operations/min.
Protection level	IP65 (IEC Standard)

Ratings

Rated Voltage	Noninductive Load (A)				Inductive Load (A)			
	Resistance Load		Lamp Load		Inductive Load		Motor Load	
	NC	NO	NC	NO	NC	NO	NC	NO
125 VAC	10	3	1.5	10	5	2.5		
250 VAC	10	2	1	10	3	1.5		
400 VAC	10	1.5	0.8	3	1.5	0.8		
8 VDC	10	6	3	10	6	6		
14 VDC	10	6	3	10	6	6		
30 VDC	6	4	3	6	4	4		
125 VDC	0.8	0.2	0.2	0.8	0.2	0.2		
250 VDC	0.4	0.1	0.1	0.4	0.1	0.1		

Cautions

To prevent the wear and the space should be within 1mm between the key and middle of the insert hole.

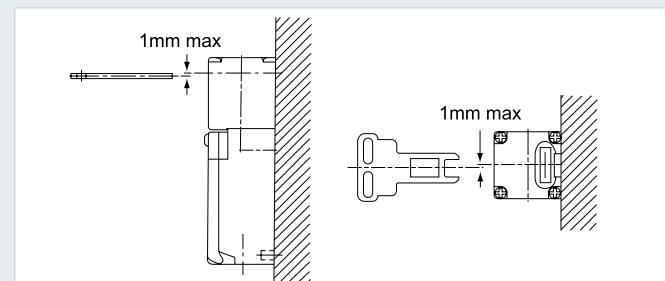

When in use, there should put a plate on the top to prevent the key overinsert. To prevent nonmovement, the space between the plate and the switch should be under 3 mm.

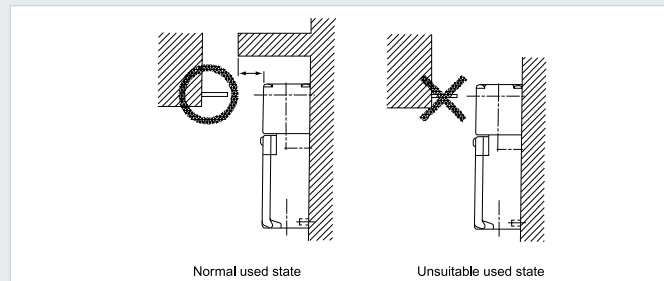

Forced Disconnecting Mechanism

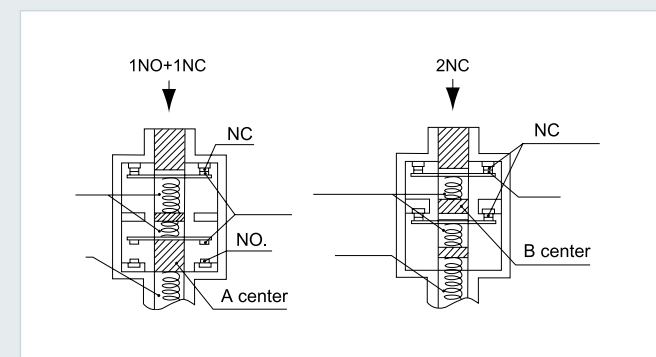

When the contact block get fire, press on the middle of the key structure, the NC strict leaving structure can push the contact block a way cut off the movement.

Operating Characteristics

Key plug in force	14.7N(1,500gf)
key pull out force	29.42N(3,000gf)
Pretravel	6 ± 3mm
Total travel	(28mm)
Force required to have positive	58.84N(6,000gf)
Positive opening travel	10mm

Appearance and Dimension

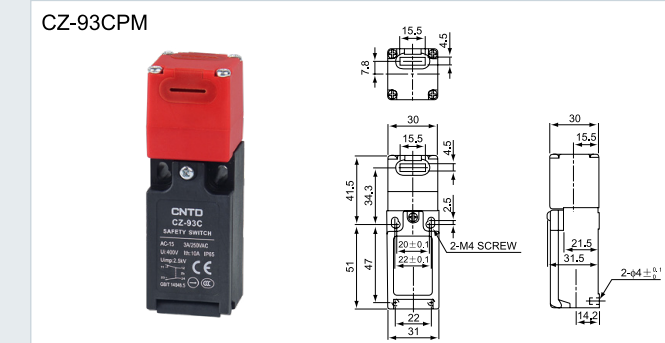

CZ-93CPM01

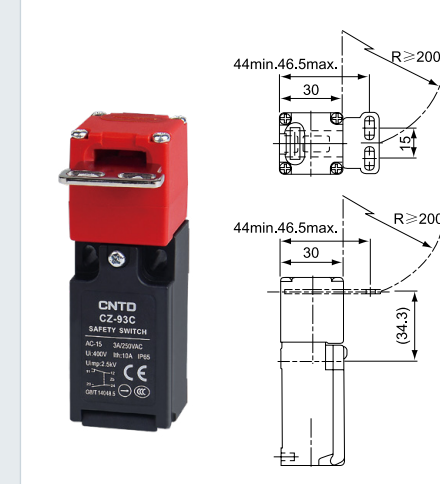

CZ-93BPM02

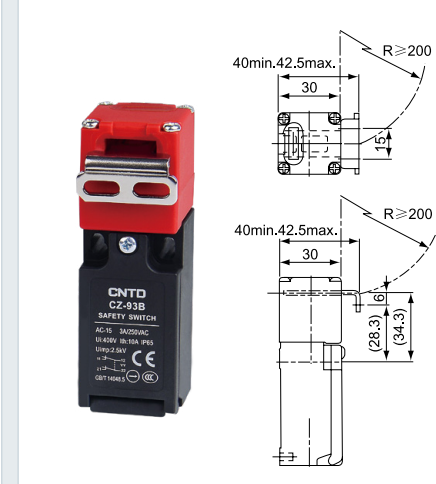

CZ-93CPM03

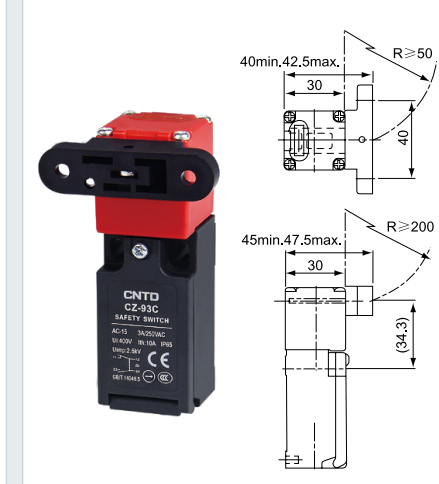

Key Dimension

CZ93-K1

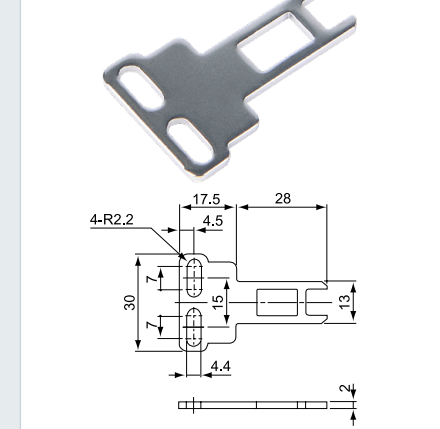

CZ93-K2

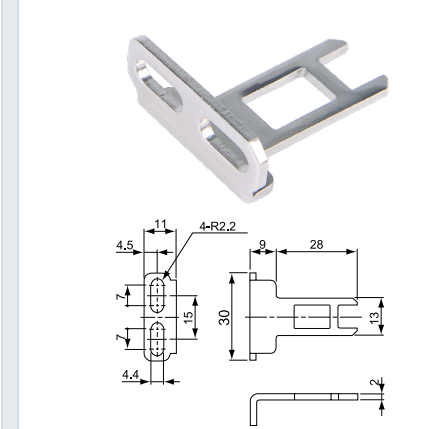

CZ93-K3

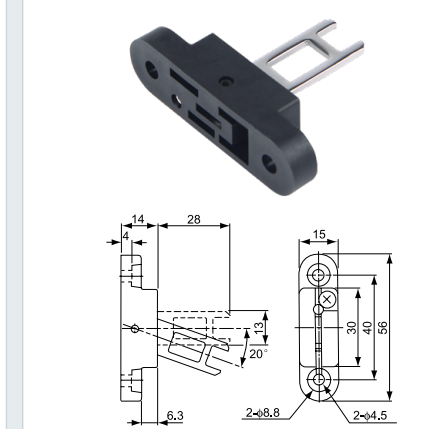



④	Head and drive rod	67	Spring type	None
		68	Metal rod coil spring type	None
		69	Tentacle type	None
		66	Plastic rod type	None
		07	Adjustable rod swing rod type	None
⑤	Outlet mode	None	Standard type (side outlet)	
⑥	Standard type (side outlet)	None	No line	
		L1~L5	1~5m	

Special Specification Code Description

Code	Description	Picture
△□	△ means: 1=1NO,2=1NC; □ Indicates: None: ungrounded. G: grounded.	RVV 0.75mm ²
D ○△□	DT type connectors (○ represents 2=DT04-2P, 3=DT04-3P, 4=DT04-4P, 6=DT04-6P; △ represents: 1=1NO,2=1NC,3=1NO1NC; □ Indicates: None: ungrounded. G: grounded	RVV 0.75mm ²
A ○△□	AMP type connectors (○ represents 2=AMP04-2P, 3=AMP04-3P, 4=AMP04-4P, 6=DAMP04-6P; △ represents: 1=1NO,2=1NC,3=1NO1NC; □ Indicates: None: ungrounded. G: grounded	RVV 0.75mm ²
M ○△□	M12 type connectors (○ represents 4=M12-4P, 5=M12-5P, 8=M12-8P; △ represents: 1=1NO,2=1NC,3=1NO1NC; □ Indicates: None: ungrounded. G: grounded	RVV 0.3mm ²

*The above special specifications, customized production according to order, product nameplate production for laser marking process; The universal model nameplate process is pad printing process.

International Certification Specifications

Certification specifications	Specifications	Document
CCC	GB/T14048.5	Please consult the CNTD Representative Office
TUV	IEC60947-5-1	

Safety Specification Certification Rating
CCC(GB/T14048.5)、TUV(IEC60947-5-1)

Type and Rating
AC-15 1.5A/240V Resistive load
DC-13 0.1A/250V Resistive load

Characteristics

Protection level	IP67	
Life	Electrical	More than 500,000 times (DC-13 24V 0.125A), more than 300,000 times (AC-15 240V 1.5A)
Operating speed	1mm-0.5m/s	
Operating frequency	Electrical: 30 operations/min	
Contact resistance	Less than 150mΩ (initial value of 1m cable), less than 200mΩ (initial value of 2m cable), less than 350mΩ (initial value of 5m cable)	
Insulation resistance	100MΩ min.(at 500VDC)	
Minimum working load	100mA resistive load below DC24V	
Rated insulation voltage (Ui)	400V complies with IEC60947-5-1	
Electric shock protection grade	Class II (double insulated)	
Pollution degree (Using conditions)	Pollution degree 3 (IEC60947-5-1)	
Withstand voltage (IEC60947-5-1)	Between homopolar terminals: 2.5kV	
	Between heteropolar terminals: 4kV	
	Between terminals and uncharged metal parts: 4kV	
Contact gap	Minimum 4*0.5mm quick action type	
Vibration	Malfunction	10~55Hz 1.5mm double amplitude
Impact	Duration	1,000m/s ²
	Malfunction	300m/s ²
Ambient temperature	Using: -25~+70℃ (With no icing)	
Ambient humidity	Less than 95% RH	
Weight	Approx 140g (C6N-P104L1), Approx 110g (C6N-P122L1)	

Operating Characteristics

Model	C6N-P	111/117L1	122/123/ 124/125L1	115/116L1	104/115/ 107/108/109L1	166/167/ 168/169L1
Operating Force	OF(Max.)	8.5N	8.5N	7N	5N	1.5N
Release Force	RF(Min.)	0.4N	0.4N	0.4N	0.4N	/
Pre-Travel	PT(Max.)	2mm	2mm	3mm	25°	20°
Over Travel	OT(Min.)	3mm	6mm	/	65°	/
Movement Differential	MD(Max.)	1mm	1mm	1.6mm	12°	10°
Operating Position	OP(mm.)	/	/	/	/	/
Total travel	TT	5mm	8mm	/	90°	/
Forced disconnected pretravel	DOT (Min.)	4.2mm	4.2mm	6.3mm	70°	/
Forced disconnected force	DOF (Min.)	42.5N	42.5N	42.5N	42.5N	/

Appearance and Dimension

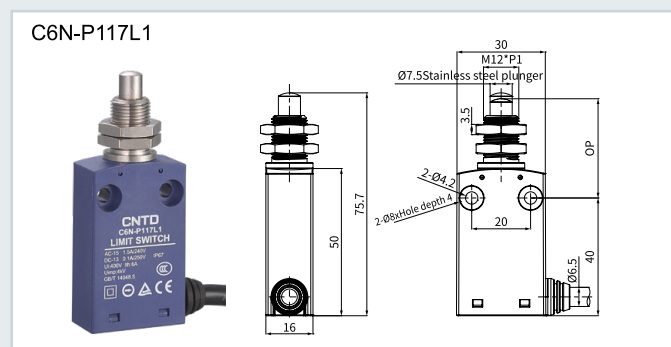
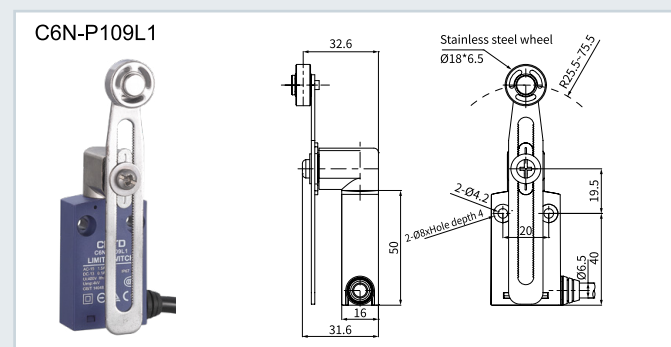
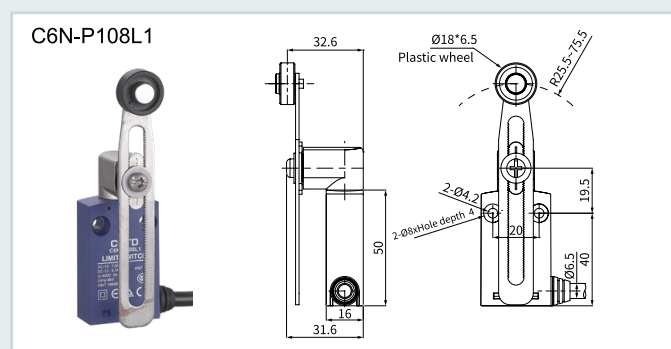
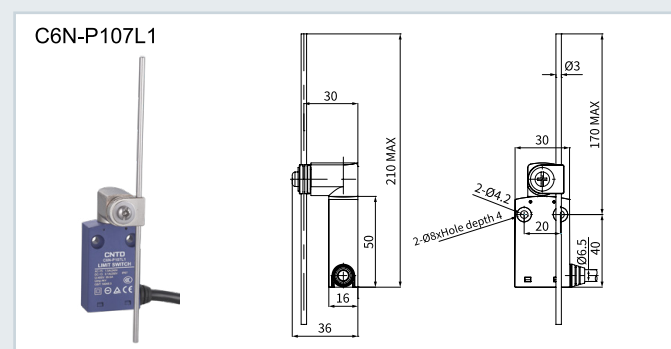
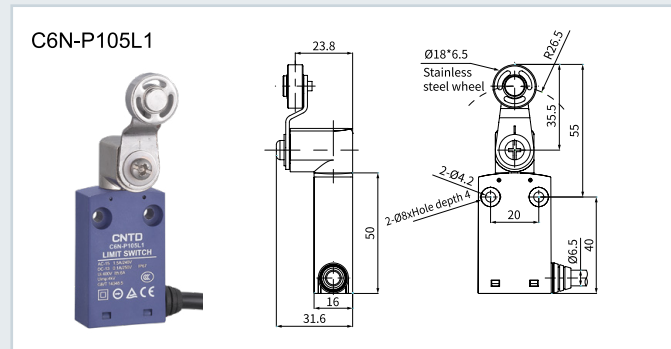
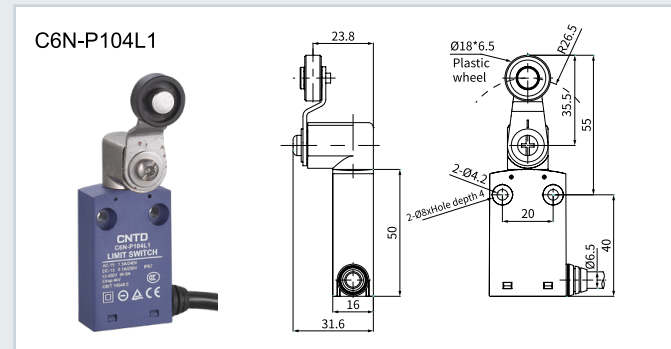
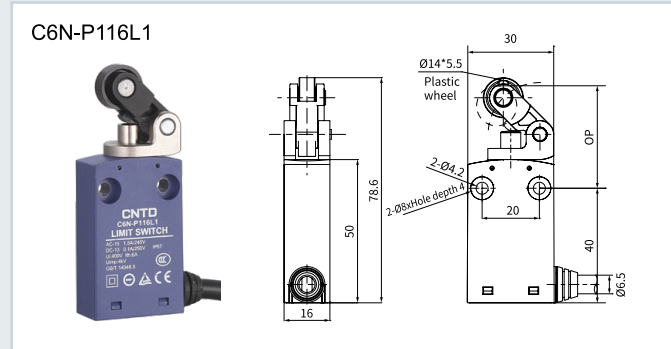
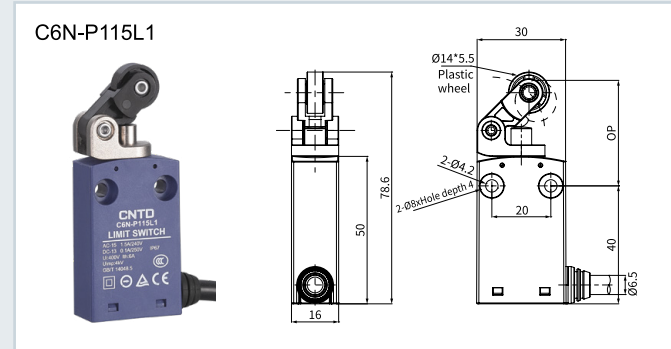
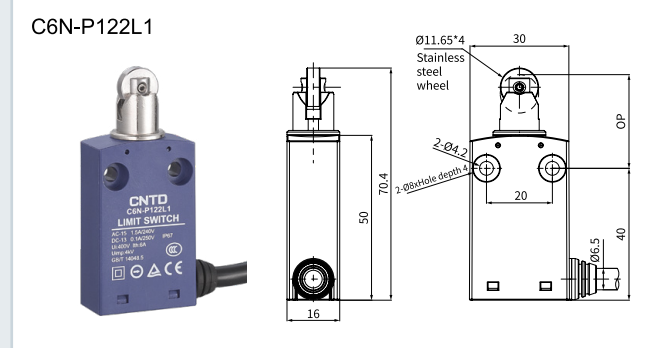
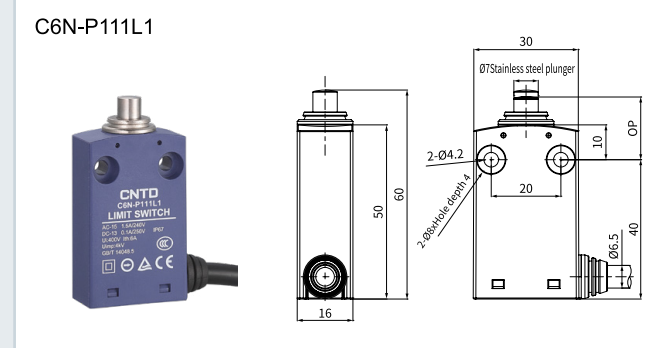

Appearance and Dimension

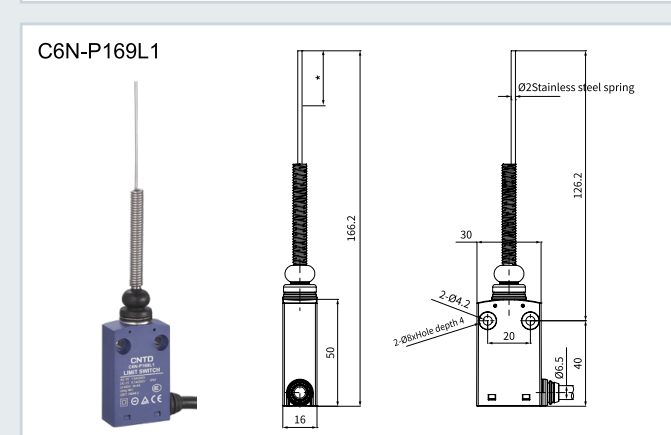
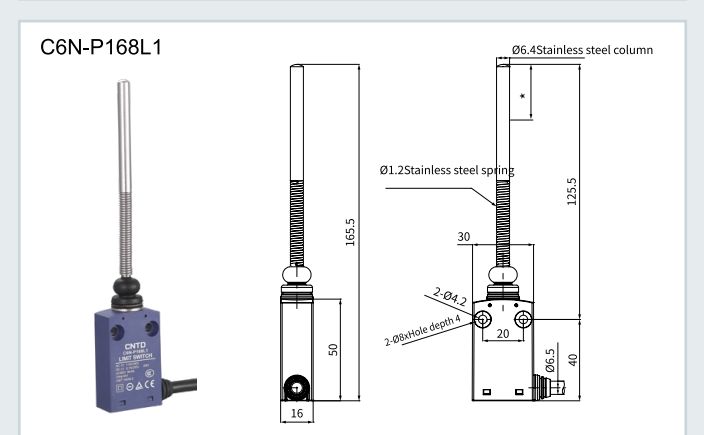
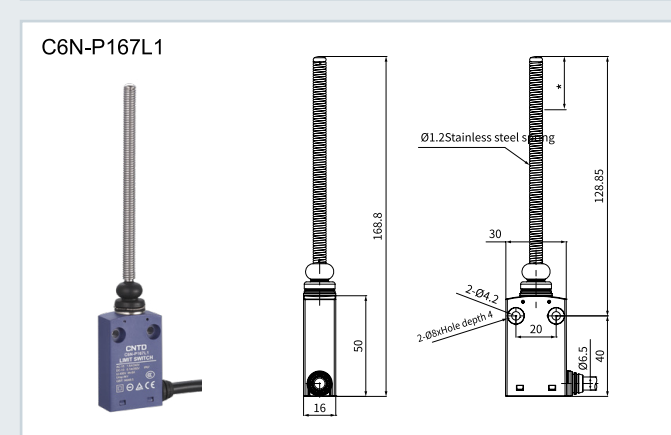
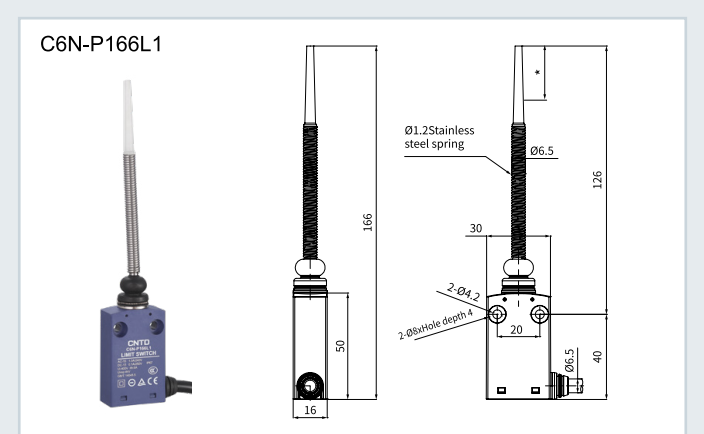
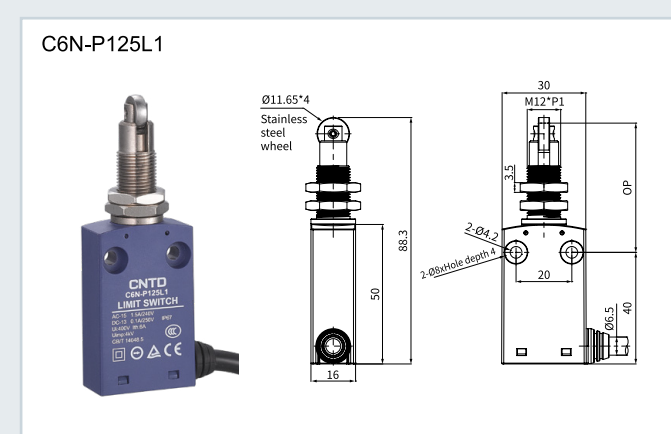
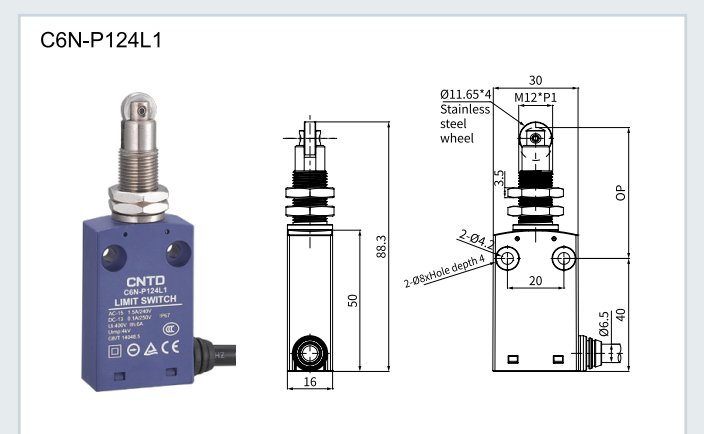
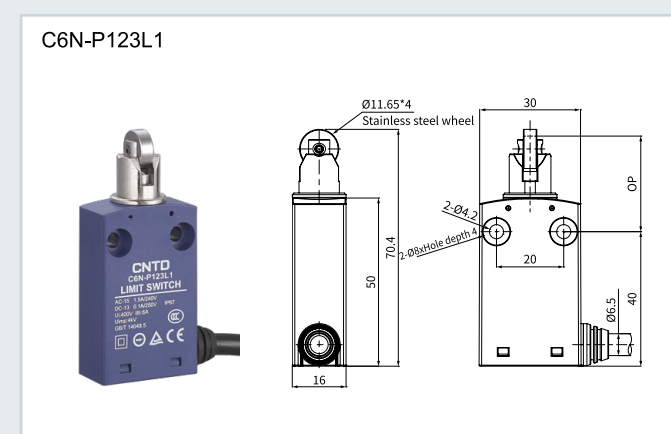



About Using the Environment

The sealing material can be spoiled. Please confirm the actual usage conditions before determining the maintenance and replacement time. Please install the switch in a location that will not directly come into contact with chips or dust. It is necessary to ensure that the drive, the moving rod and switch body will not accumulate cutting chips and mud-like substances.

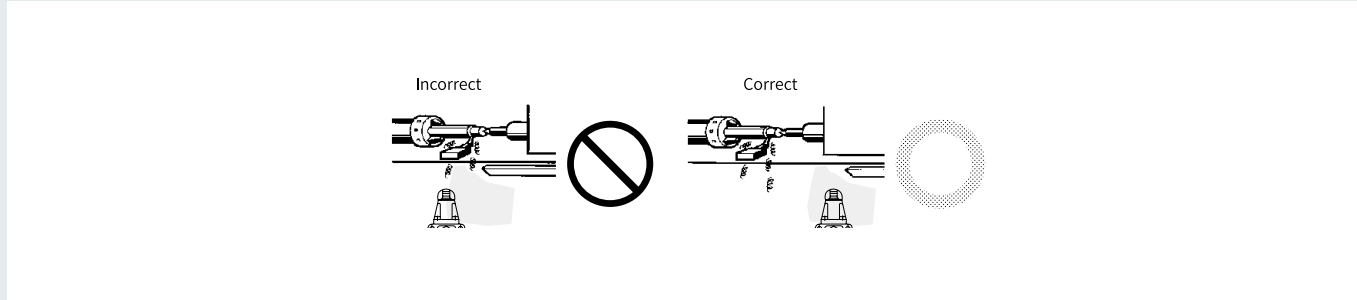

When the switch is subjected to continuous vibration and impact, the generated wear powder may cause contact connection, poor contact, abnormal movement, decreased durability, and other issues. In addition, if there is excessive vibration and impact, which may cause contact malfunction and damage, so please install it in a position that will not be subjected to vibration and impact, and in a direction that will not resonate.

The switch has physical contacts. If silicon gas is present in the environment, the arc energy will cause silicon dioxide (SiO₂) to accumulate on the contacts, resulting in poor contact. There is silicone oil around the switch. When using silicon fillers, silicon wires, and other silicon products, please use contact protection circuits to suppress arcing and eliminate the source of silicon gas generation.

Operate

The operating method, shape of the cam or stop, operating frequency, and overtravel all significantly affect the service life and the accuracy of the limit switch. Due to this reason, the angle of the stop must be below 30°, the surface roughness of the stop must be above 6.3 S, and the hardness must be Hv 400 to 500.

To ensure the correct movement of the plunger type drive rod, adjust the stop and cam to the correct setting position. The correct position is the position where the plunger groove matches the top of the sleeve.

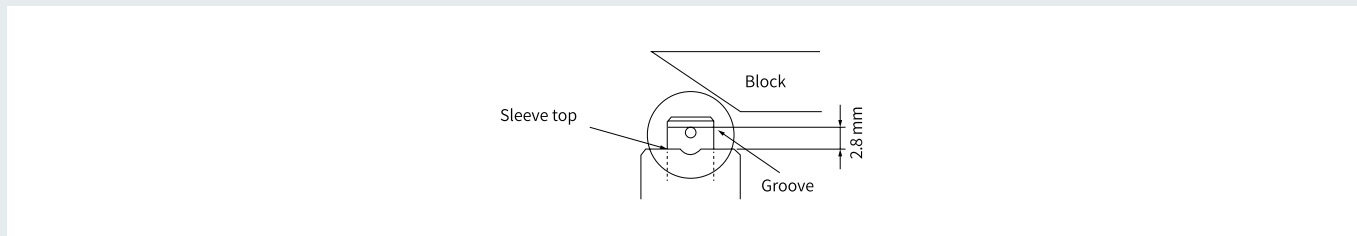

To allow the ball swing rod type drive rod to move correctly, adjust the stop and cam so that the arrow is positioned between the two protruding marks, as shown below.

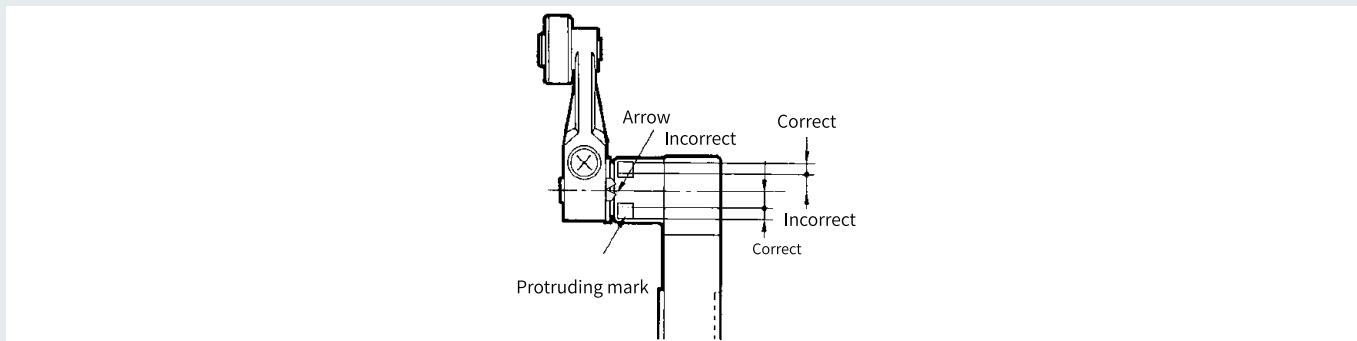

On the Use of Small Load Models

The use of a general load switch in the switching of a small load circuit will cause contact failure. The use of a small load type, if the switch will occur surge current load, will also aggravate the contact consumption, shorten the service life, so please insert the necessary contact protection circuit. The minimum applicable load is the N-level reference value. This represents the level of the fault level at a reliability level of 60% ($\lambda \geq 60$). $\lambda \geq 60 = 0.5 \times 10^{-6}$ /time indicates that the presumed failure rate is less than 1/2,000,000 at a reliable level of 60%.

Precautions for use

Switch contacts can be used for general loads or small loads. However, contacts that have already been connected to general loads cannot be used to connect smaller capacity loads. Otherwise, it may lead to roughness of the contact surface and loss of contact reliability.

Mounting hole

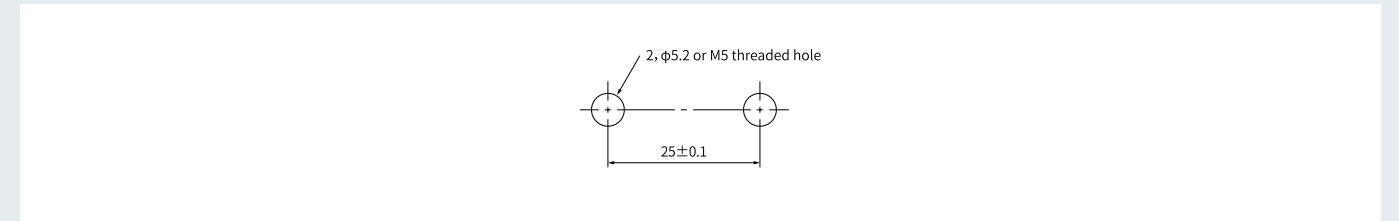

Plunger type may malfunction due to harsh environments, such as dust or cutting debris causing poor reset. In this case, please use a model with a rubber cap.

Do not come into contact with water exceeding 70 °C or use under steam.

Tighten each screw to the corresponding torque according to the table below.

Number	Types of	Correct tightening torque*
1	M4 swing rod mounting screws	1.2~1.4N·m
2	M4 installation torque	0.6~0.8N·m

*By removing two screws from the head, the head direction can be rotated 180°. When changing the direction of the head, then tighten to the torque specified above. Be careful not to allow any impurities to enter the switch.

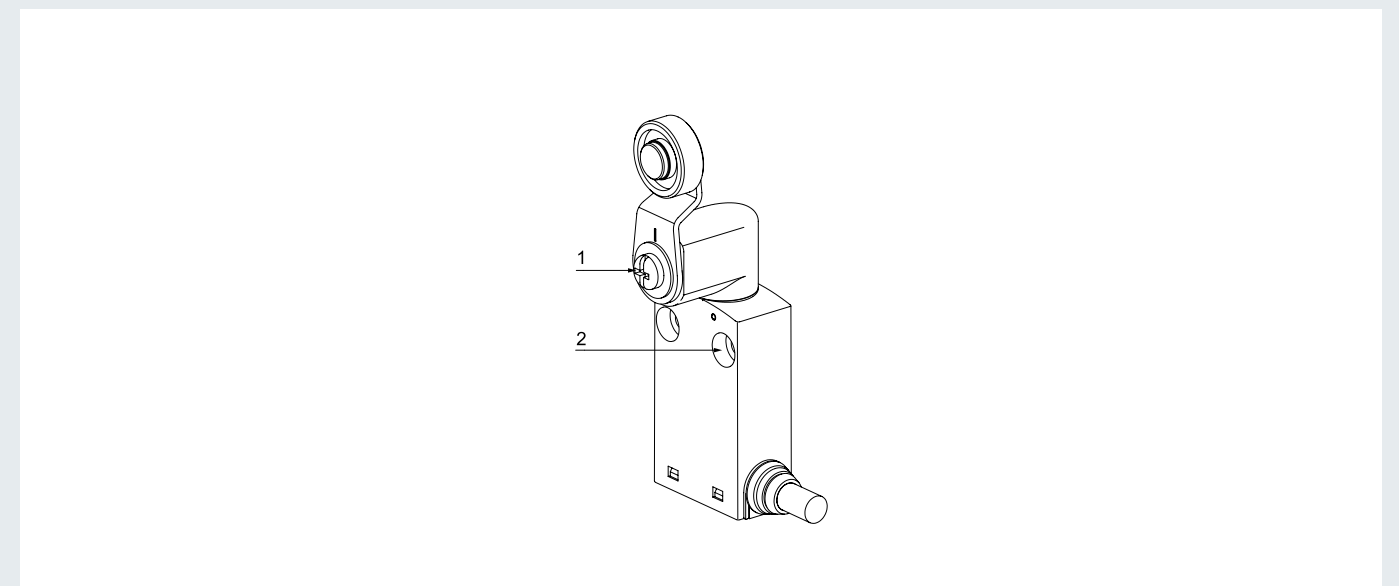



Wiring precautions

Do not wire the switch while it is powered on. Otherwise, it may cause electric shock.
 When wiring, do not allow small wires or other particles to enter the switch body.
 When connecting terminals through insulated pipes and M3.5 crimping terminals, please configure the crimping terminals as shown in the figure to ensure that they are not pressed onto the outer shell or cover.
 The applicable wire size is: AWG20~AWG18 (0.5~0.75mm²).
 Please use wires of appropriate length for wiring. Otherwise, it may cause the outer cover to arch or fail to secure properly.
 Do not insert crimped terminals into the gaps in the casing, as this may cause damage or deformation to the casing.
 To avoid contact between the terminals and the inside of the switch housing, please use terminals with a thickness of less than 0.5mm.

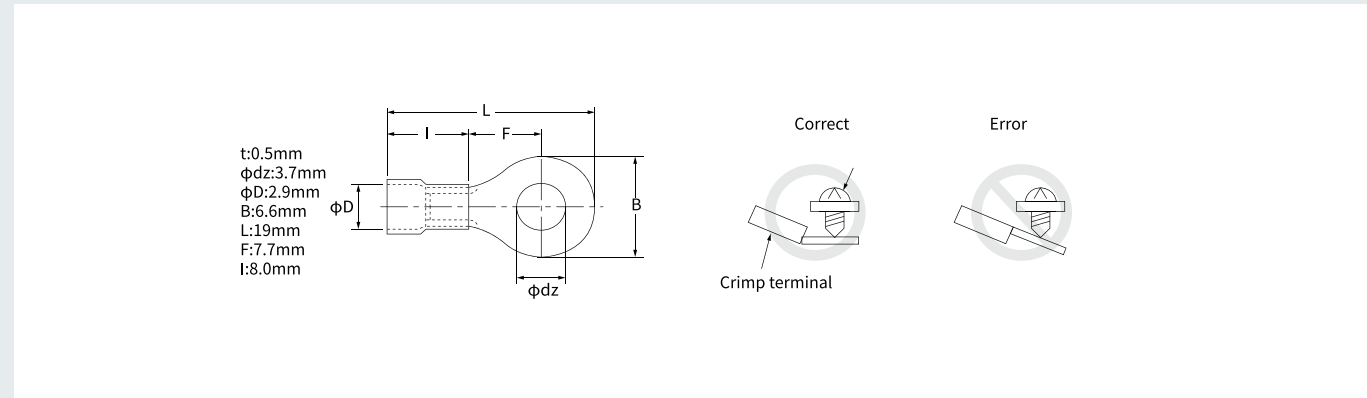

Applicable conductor

Wire name	Using wires		
	Number of cores	Conductor	Nom OD
Plastic rubber insulated flexible wire	2-core 3-core 4-core	0.75mm ²	Circular φ 6~φ 9
600V plastic insulation Plastic sheathed cable	2-core	φ 1/φ 1.2/φ 1.6	

Note: If it contains silicon, it may cause poor contact. Please do not use it.

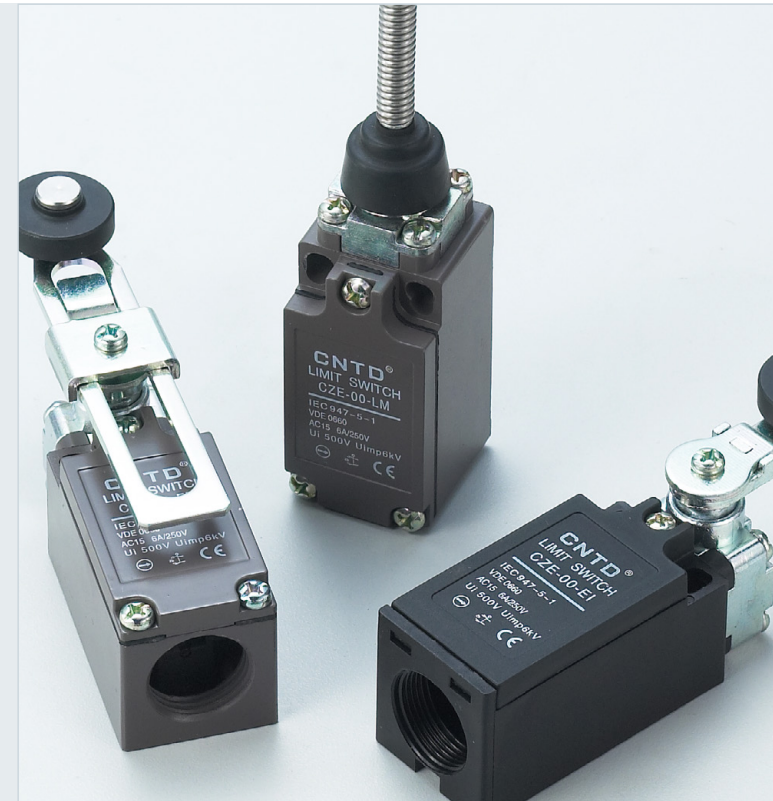

Actuators available

Direct movement

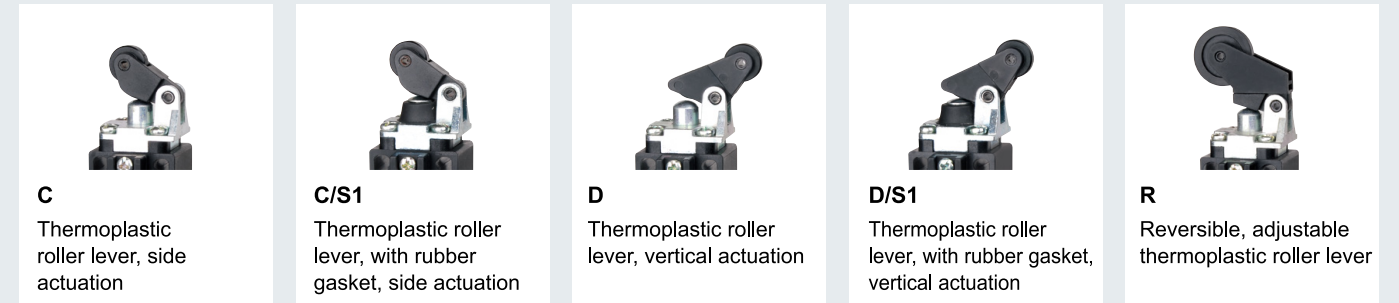
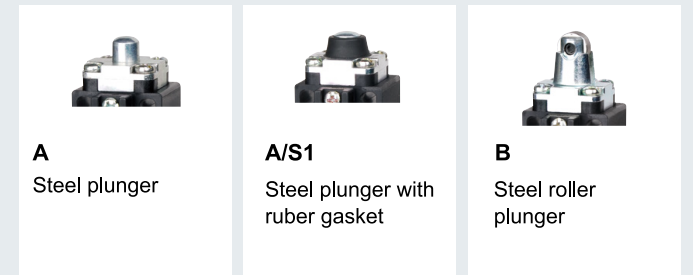

Angular movement

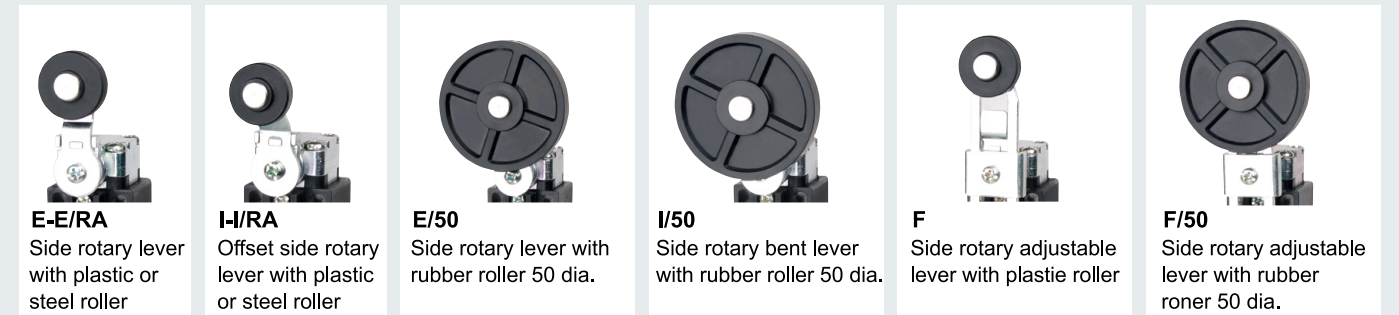

Multi-directional movement

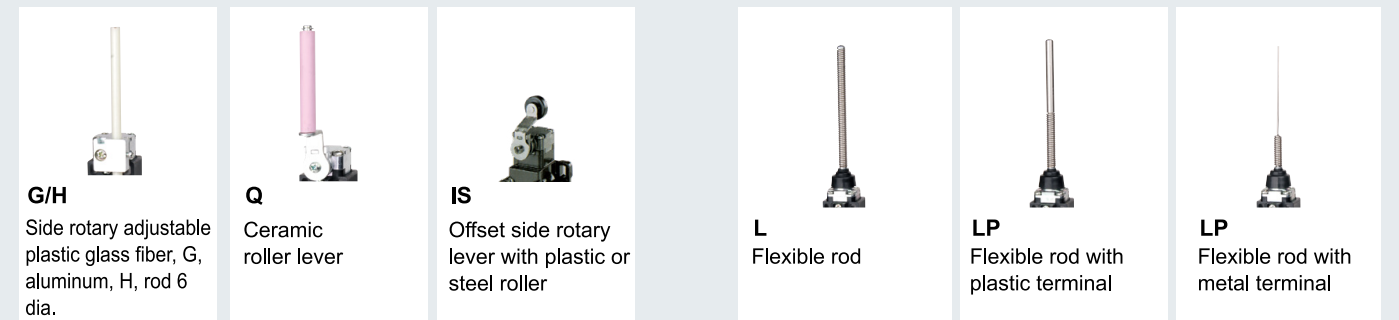

General feature

Operating frequency		operat./sec (Hz)	1		
Insulation resistance	500 V DC	MΩ	100		
Dielectric strength	50/60 Hz per 1*	V AC	2500		
Rated insulation voltage	Ui IEC947-5-1	V AC	500		
Rated thermal current	Ithe IEC947-5-1	A	10		
Rated operating current	IEC 947-5-1/EN60947-5-1				
Category AC15 A300	le	24V	A	10	
		125V	A	6	
		230V	A	4	
		400V	A	3	
		Category DC13 Q300	le	24V	A
48V	A	4			
120V	A	1			
250V	A	0.4			
Contact resistance	IEC255-7 cat.3	initial value	MΩ	25	
Short circuit protective devices	IEC269(IEC947-5-1) gl or gG type fuse		A	10	
Rated conditionals short circuit current	IEC947-5-1		A	100	
Pollution degree	IEC947-5-1			3	
Protection degree	EN 60529		IP	66	
Protection against electric shock	plastic	class		II	
	metal	class		I	
Vibration resistance	IEC68-2-6	mm		0.35 ± 15%(10 ÷ 55 Hz ± 1 Hz)	
Shock resistance	IEC68-2-27	11 ms	g	30	
Mechanical life		cycles min		15.000.000	
Electrical life		at 250VAC 6A with resistance load cos β =1	cycles min	500.000	
		at 250VAC 6A with resistance load cos β =0.4	cycles min	500.000	
Distance between contacts	snap action type	mm		2 × 1, 25	
	low action type	mm		2 × 2	
Terminals	type	Screw with combined notch and retrivable plate (notch Ph. size 1)			
	screw	M		3, 5	
	protection degree	IP		20A	
	material	Steel class 8.8/Galvanized			
	Max. screw tightening torque	N cm (kg cm)		120(12, 24)	
	max connecting capacity	rigid cable	mm ²		2 × 1, 5
		flexible cable	mm ²		2 × 1, 5
	with prod terminal	mm ²			1 × 1, 5
terminal numbering	In accordance with EN50013				

Contact block

1 NO+1 NC	fast action	00
1 NO+1 NC	slow action	01
1 NO+1 NC	slow overlapping action	02
2 NO	slow action	03
2 NC	slow action	04
2 NC	fast action	05
2 NO+2 NC	fast action	000(excluded E200) 000(E200 除外)
1 NO+3 NC	slow action	80 (model E400 only) 80(E400)
2 NO+2 NC	slow action	81 (model E400 only) 81 (E400)

Plastic Version

<p>CZE-00-AI</p>	<p>CZE-00-AI/SI</p>
<p>CZE-00-BI</p>	<p>CZE-00-CI</p>
<p>CZE-00-CI/SI</p>	<p>CZE-00-DI</p>
<p>CZE-00-DI/SI</p>	<p>CZE-00-EI</p>
<p>CZE-00-II</p>	<p>CZE-00-EI/50</p>

Plastic Version

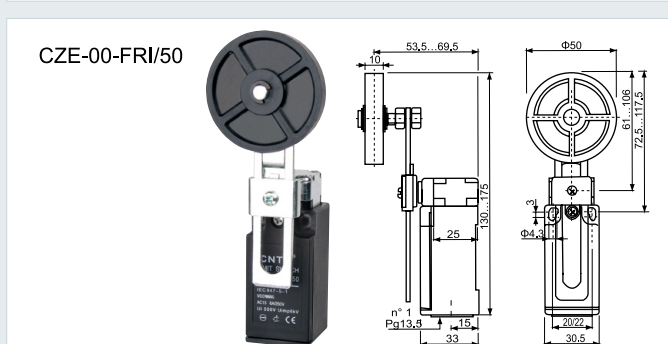
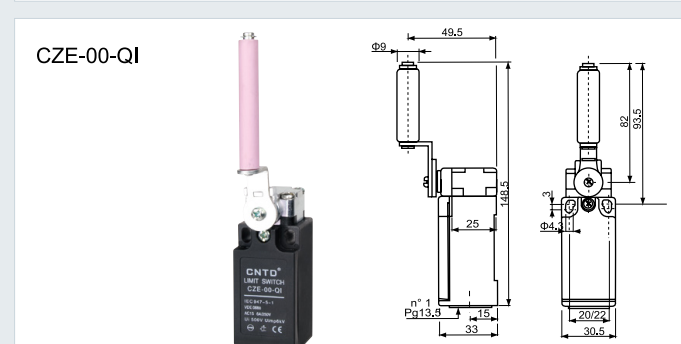
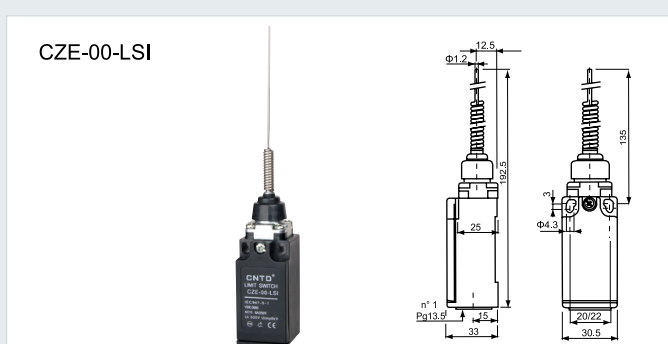
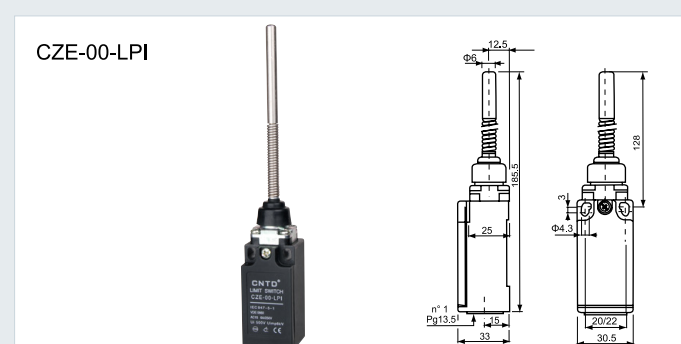
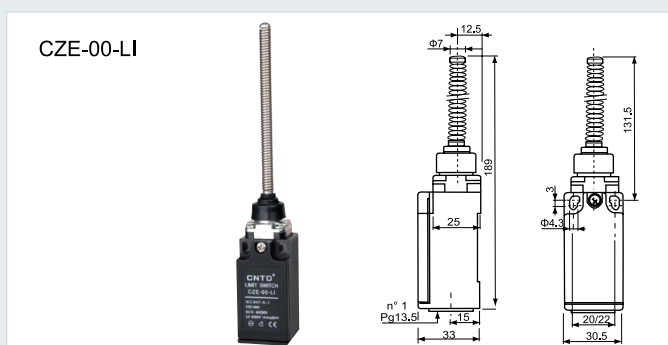
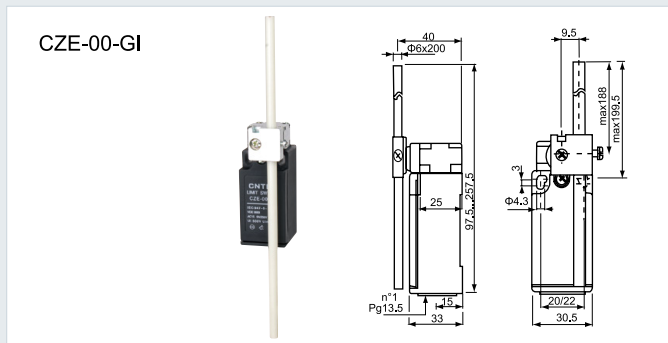
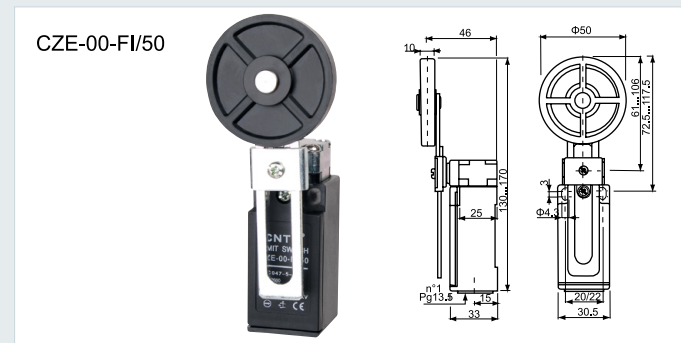
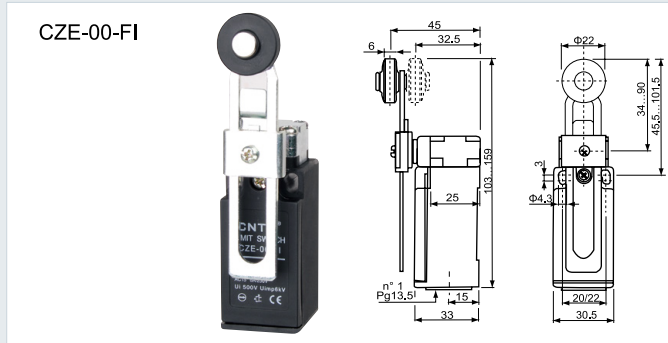
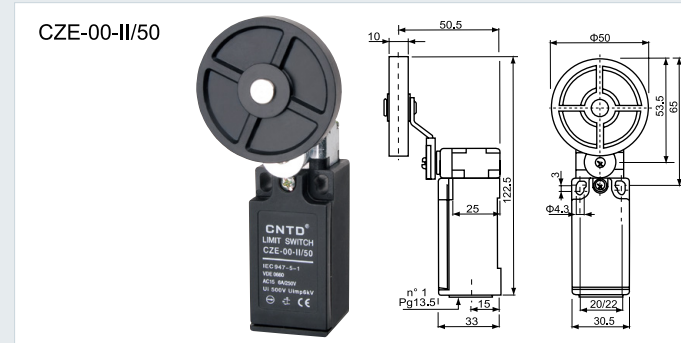

Metal Version

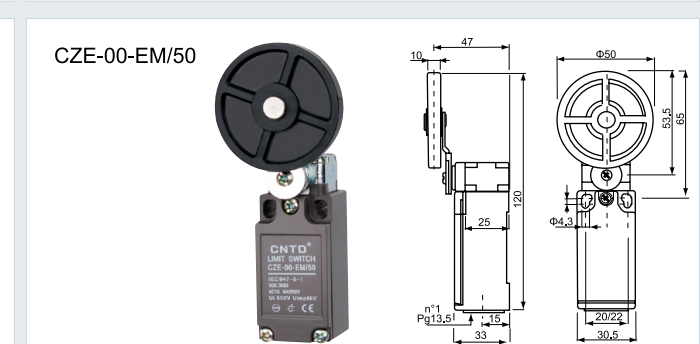
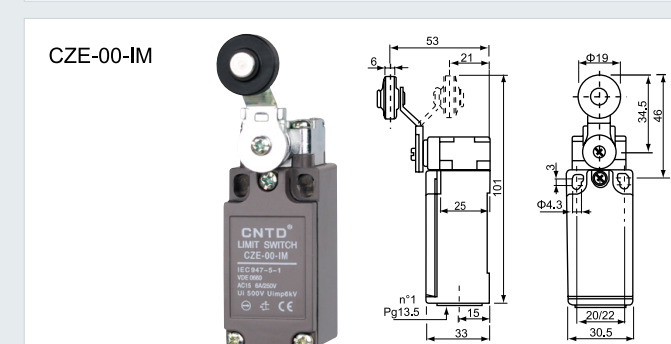
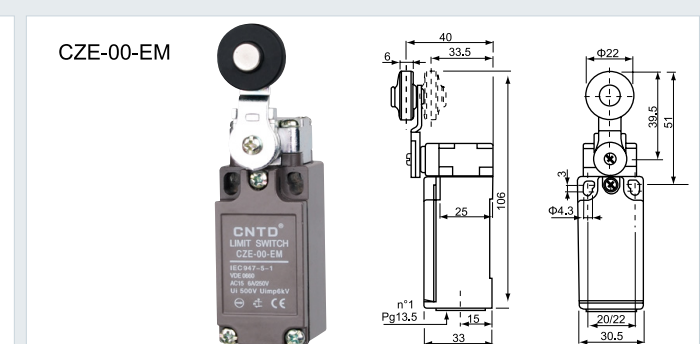
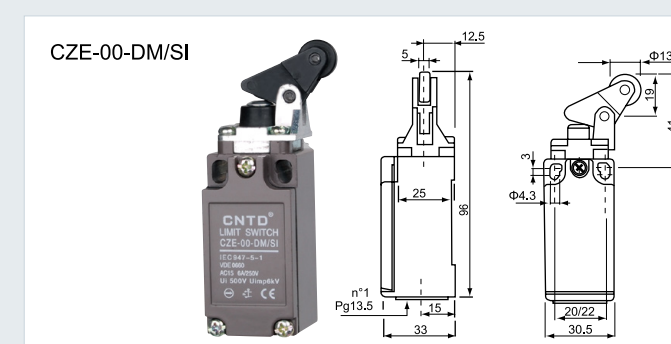
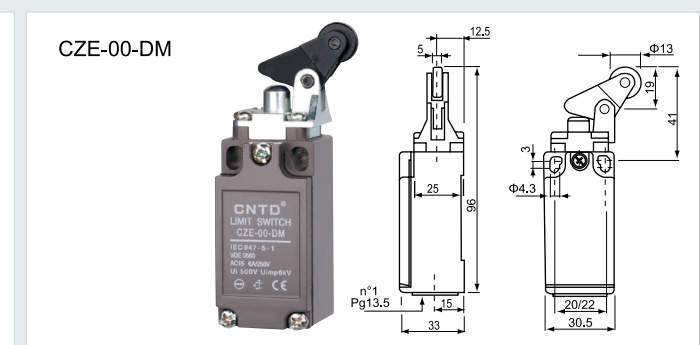
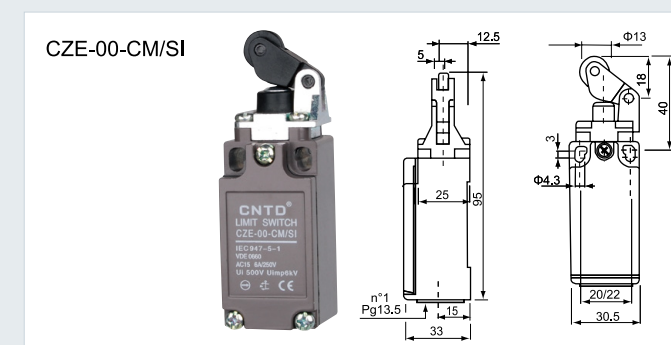
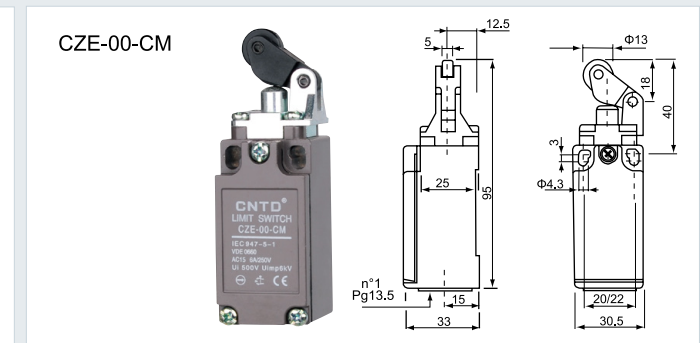
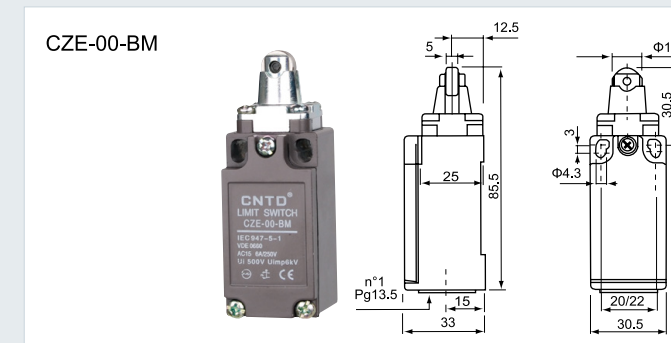
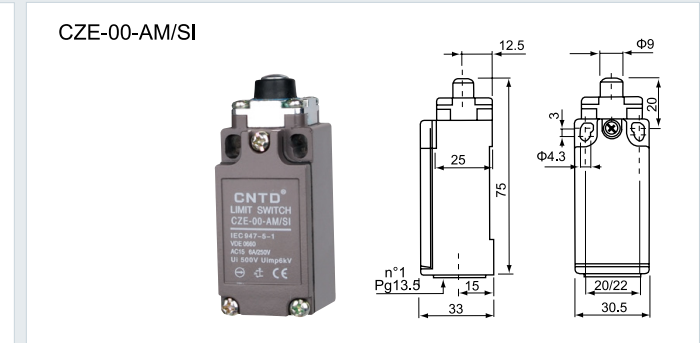
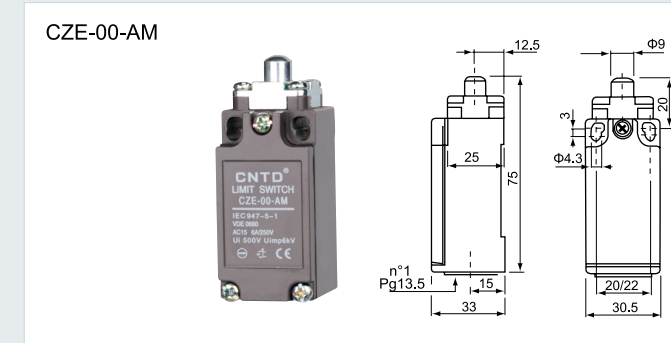

Operating Characteristics

Models	CM1300	CM1301	CM1303 CM1303M	CM1305	CM1306	CM1307	CM1308 CM1308X	CM1309	CM1701 CM1706	CM1702	CM-1703 CM-1703M	CM-1704 CM-1704M	CM1705	CM-1743 CM-1743M
OF(Max.)	350g	300g	300g	350g	350g	350g	350g	350g	70g	160g	100g	160g	10g	160g
RF(Min.)	114g	50g	50g	114g	114g	114g	114g	114g	14g	28g	22g	42g	3g	42g
PT(Max.)	0.4mm	4mm	4mm	0.4mm	0.4mm	0.4mm	0.4mm	0.4mm	10mm	5mm	7.1mm	2.7mm	20mm	2.7mm
OT (Min.)	0.13mm	1.6mm	1.6mm	1.6mm	1.6mm	5.5mm	3.58mm	3.58mm	5.6mm	2mm	4mm	2.4mm	5.6mm	2.4mm
MD (Max.)	0.05mm	1.3mm	1.3mm	0.05mm	0.05mm	0.05mm	0.05mm	0.05mm	1.27mm	1mm	1.02mm	0.5mm	3mm	0.5mm
FP(Max.)		20.6mm	31.8mm						28.2mm	24.8mm	36.5mm	32.5mm		43.6mm
OP(mm)	15.9 ± 0.4	17.4 ± 0.8	28.6 ± 0.8	28.2 ± 0.5	21.5 ± 0.5	21.8	33.4 ± 1.2	33.4 ± 1.2	19 ± 0.8	19 ± 0.4	30.2 ± 0.8	30.2 ± 0.4	19 ± 0.8	43.1 ± 0.8

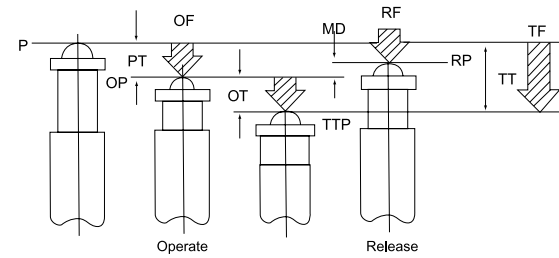

OF: Operating Force
 RF: Releasing Force
 TF: Total Force
 FP: Free Position
 OP: Operating Position
 RP: Releasing Position
 TTP: Total Tavel Position
 PT: Pre Travel
 OT: Over Travel
 MD: Movement Differential
 TT: Total Tavel

Appearance and Dimension

CM-1701

CM-1702

CM-1703

CM-1703M

CM-1704

CM-1704M

Appearance and Dimension

CM-1705

CM-1706

CM-1306

CM-1307

CM-1308

CM-1309

CM-1308X

CM-1743

CM-1743M

CM-1300

Appearance and Dimension

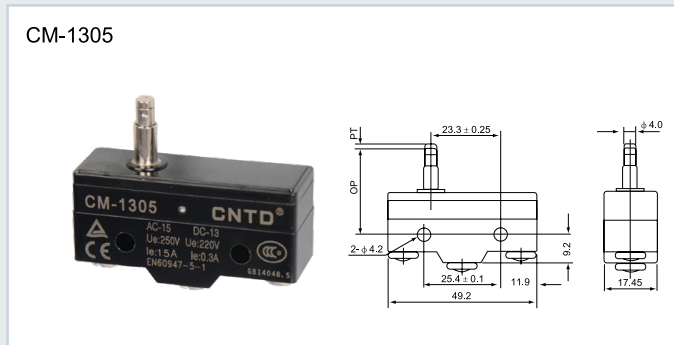
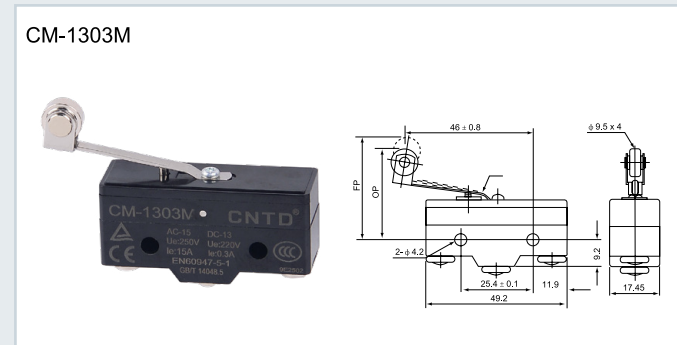
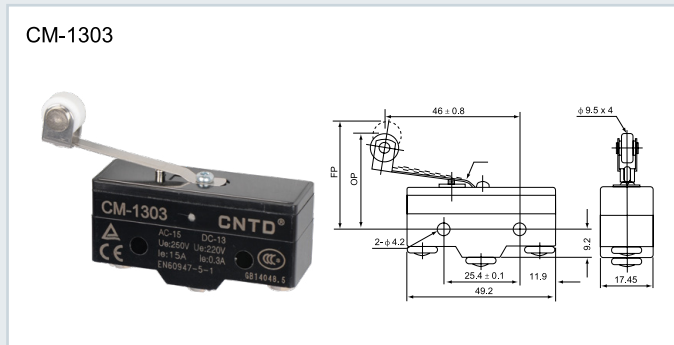
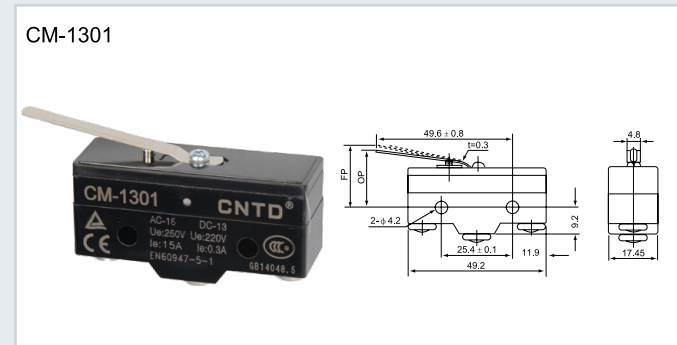

Features

- Engineering plastics shell for resistant construction
- Various actuators and some with adjustable operating position (such as CM1701N)
- High accuracy wide range of operation speed

Contact Form

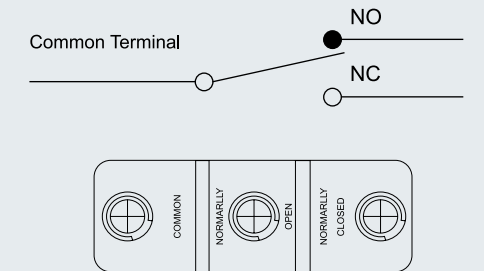

Terminal Cover



Ratings

Rated Voltage	Noninductive Load (A)				Inductive Load (A)				Inrush Current	
	Resistance Load		Lamp Load		Inductive Load		Motor Load			
	NC	NO	NC	NO	NC	NO	NC	NO	NC	NO
125VAC	15	3	1.5		15	5	2.5		30 max.	15 max.
250VAC	15	2.5	1.25		15	3	1.5			
500VAC	3	1.5	0.75		2.5	1.5	0.75			
8VDC	15	3	1.5		15	5	2.5			
14VDC	15	3	1.5		10	5	2.5			
30VDC	6(2)	3	1.5		5	5	2.5			
125VDC	0.4	0.4	0.4		0.05	0.05	0.05			
250VDC	0.2	0.2	0.2		0.03	0.03	0.03			

Specifications

Operation speed	0.05mm-1m/s
Operating frequency	Electical: 20 operations/min.
Contact resistance	15mΩ max. (initial value)
Insulation resistance	100mΩ min. (at 500VDC)
Dielectric Strength	1000VAC, 50/60 Hz for 1 minute between terminals of the same polarity
	1500VAC, 50/60 HZ for 1 minute between current-carrying and non-current-carrying metal parts
Dielectric Strength	1500VAC, 50/60 HZ for 1 minute between each terminal and ground
Vibration	(*10 to 20Hz): 1.5 Vibration amplitude action duration: 10 to 55Hz
Shock	Mechanical durable: 1,000m/Sec ² (about 100G'S) Malfunction: 300m/Sec ² (about 30G'S)
Ambient temperature	Using: -20~+70°C (With no icing)
Humidity	General purpose type: 85% RH max., Sealed type: 95% RH max.
Electrical life	500,000 operations above
Weight	About 22 to 58g

Operating Characteristics

Models	CM1300N	CM1301N	CM1303N CM1303NM	CM1305N	CM1306N	CM1307N	CM1308N CM1308XN	CM1309N	CM1701N CM1706N	CM1702N	CM1703N CM1703NM	CM1704N CM1704NM	CM1705N	CM1743N CM1743NM	
OF(Max.)	350g	300g	300g	350g	350g	350g	350g	350g	70g	160g	100g	160g	10g	160g	
RF(Min.)	114g	50g	50g	114g	114g	114g	114g	114g	14g	28g	22g	42g	3g	42g	
PT (Max.)	0.4mm	4mm	4mm	0.4mm	0.4mm	0.4mm	0.4mm	0.4mm	10mm	5mm	7.1mm	2.7mm	20mm	2.7mm	
OT(Min.)	0.13mm	1.6mm	1.6mm	1.6mm	1.6mm	5.5mm	3.58mm	3.58mm	5.6mm	2mm	4mm	2.4mm	5.6mm	2.4mm	
MD (Max.)	0.05mm	1.3mm	1.3mm	0.05mm	0.05mm	0.05mm	0.05mm	0.05mm	1.27mm	1mm	1.02mm	0.5mm	3mm	0.5mm	
FP (Max.)		20.6mm	31.8mm						28.2mm	24.8mm	36.5mm	32.5mm		43.6mm	
OP(mm)	15.9 ± 0.4	17.4 ± 0.8	28.6 ± 0.8	28.2 ± 0.5	21.5 ± 0.5	21.8	0.8	33.4 ± 1.2	33.4 ± 1.2	19 ± 0.8	19 ± 0.4	30.2 ± 0.8	30.2 ± 0.4	19 ± 0.8	43.1 ± 0.8

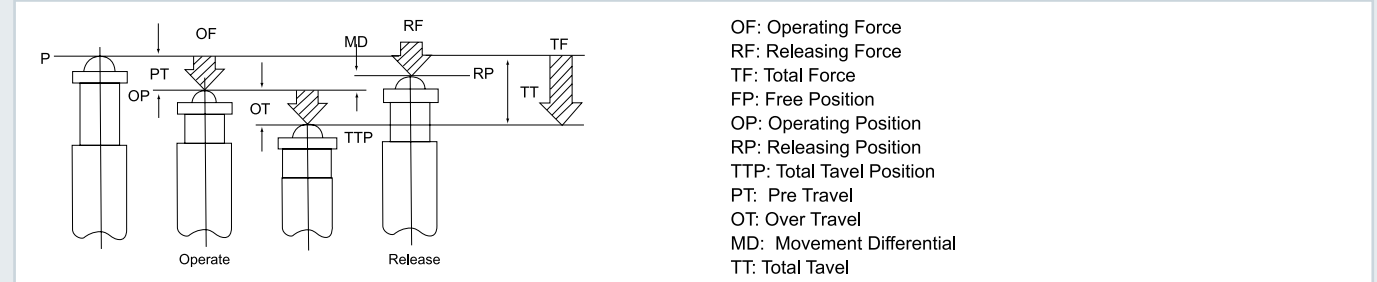

Appearance and Dimension

Grid of appearance and dimension drawings for models CM-1701N, CM-1702N, CM-1703N, CM-1703NM, CM-1704N, CM-1704NM, CM-1705N, and CM-1706N. Each entry includes a photograph of the component and a detailed technical drawing with dimensions.

Appearance and Dimension

Grid of appearance and dimension drawings for models CM-1306N, CM-1307N, CM-1308N, CM-1309N, CM-1308XN, CM-1743N, CM-1308NM, CM-1743NM, CM-1301N, CM-1303N, CM-1303NM, CM-1301NM, and CM-1305N. Each entry includes a photograph of the component and a detailed technical drawing with dimensions.



Features

- Various actuators and some with adjustable operating position (such as CZ-7121)
- Shell covered with intensive plastic for water-proof and oil-proof. The mechanical strength is better than CM series of horizontal limit switch

Contact Form

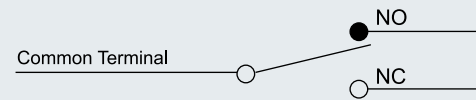

Ratings

Rated Voltage	Noninductive Load (A)			Inductive Load (A)				
	Resistance Load		Lamp Load	Inductive Load		Motor Load		
	NC	NO	NC	NO	NC	NO	NC	NO
125VAC	10	3	1.5	10	5	2.5		
250VAC	10	2.5	1.25	10	3	1.5		
480VAC	3	1.5	0.75	2.5	1.5	0.75		
8VDC	10	3	1.5	6	6	5		
14VDC	10	3	1.5	6	6	5		
30VDC	8	3	1.5	6	5	2.5		
125VDC	0.5	0.4	0.4	0.05	0.05	0.05		
250VDC	0.25	0.2	0.2	0.03	0.03	0.03		

NOTES: 1. Inductive load has a power factor of 0.4 min.(AC) and a time constant of 7 msec.max.(DC).
 2. Lamp load has an inrush current of 10 times the steady-state current, while motor load has an inrush current of 6 times the steady-state current.
 3. Product with spring, its usable range of operating part is within one third of the whole spring length from the front end of spring.

Specifications

Operation speed	0.05mm-0.5m/s
Operating frequency	Electical: 20 operations/min.
Contact resistance	25mΩ max. (initial value)
Insulation resistance	100mΩ above(at 500VDC)
Dielectric strength	1000VAC, 50/60 Hz for 1 minute between terminals of the same polarity
	1500VAC, 50/60 Hz for 1 minute between current-carrying and non-current-carrying metal parts
Vibration	Malfunction Duration: 10-55Hz, 1.5mm double amplitude
Shock	Mechanical durable: 1,000m/Sec ² (about 100g's) Malfunction: 300m/Sec ² (about 30g's)
Ambient temperature	Using: -20~+70℃ (With no icing)
Humidity	< 95% RH
Electrical life	500,000 operations above
Weight	About 60g

Operating Characteristics

Model	CZ-7	CZ-7100	CZ-7110	CZ-7310	CZ-7311	CZ-7312	CZ-7120	CZ-7140	CZ-7121	CZ-7141	CZ-7124	CZ-7144	CZ-7166
Operating force	OF(Max.)	600g	600g	600g	600g	600g	150g	220g	180g	240g	200g	280g	120g
Release force	RF(Min.)	100g	100g	100g	100g	100g	40g	60g	50g	80g	60g	100g	
Pre-travel	PT(Max.)	2.0mm	2.0mm	2.0mm	2.0mm	2.0mm	13.5mm	8.5mm	11.0mm	6.5mm	11mm	6.5mm	250mm
Over travel	OT(Min.)	0.8mm	5.0mm	6.0mm	6.0mm	6.0mm	4.0mm	2.5mm	3.0mm	2.0mm	3.0mm	2.0mm	11mm
Movement differential	MD(Max.)	0.8mm	0.8mm	0.8mm	0.8mm	0.8mm	3.2mm	2.0mm	2.4mm	1.5mm	2.4mm	1.5mm	
Operating position	OP(mm.)	30.5 ± 0.8mm	44 ± 1.2mm	21.8 ± 1.2mm	33.3 ± 1.2mm	33.3 ± 1.2mm	25 ± 1mm	25 ± 1mm	40 ± 1mm	40 ± 1mm	50 ± 1.2mm	50 ± 1.2mm	
Free Position	FP						35mm	32mm		46mm		56mm	

Appearance and Dimension

<p>CZ-7121</p>	<p>CZ-7141</p>
<p>CZ-7120</p>	<p>CZ-7140</p>
<p>CZ-7124</p>	<p>CZ-7144</p>
<p>CZ-7100</p>	<p>CZ-7110</p>
<p>CZ-7310</p>	<p>CZ-7311</p>
<p>CZ-7312</p>	<p>CZ-7166</p>

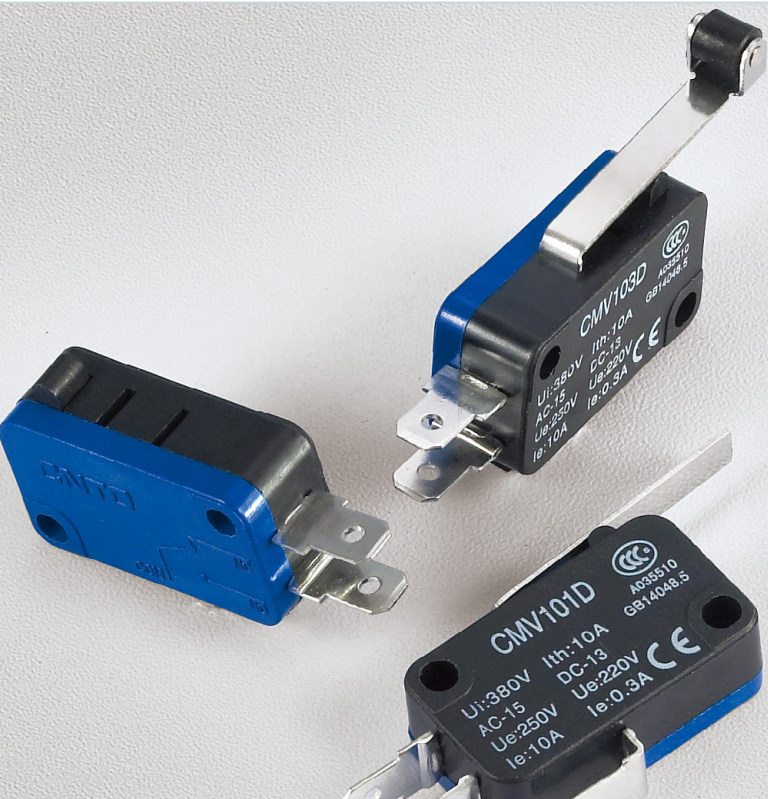

Model Number Structure

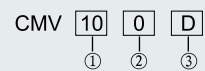

Item	Code	Description
① Rated Current	10	10A
② Head and driving rod	0	Button type
	1	Long handle type
	2	Short shank type
	3	Long pulley type
	4	Short pulley type
	5	Longer handle type
③ Terminal specifications	C	#250 terminal
	D	#187 terminal

Appearance and Dimension

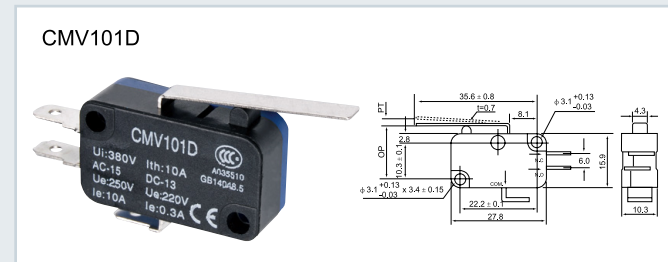
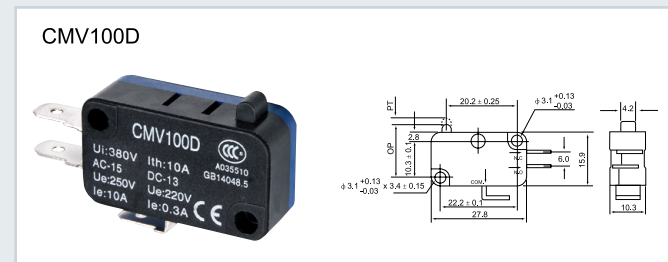

Ratings

Item	Rated Voltage	Noninductive Load (A)				Inductive Load (A)				Inrush Current	
		Resistance Load		Lamp Load		Inductive Load		Motor Load			
		NC	NO	NC	NO	NC	NO	NC	NO		
Spec.	250VAC	10		1.5		6		2		24 max.	
	8VDC	10		3		6		3			
	30VDC	6		3		6		3			
	125VDC	0.3		0.1		0.6		0.1			
	250VDC	0.3		0.05		0.3		0.05			

Specifications

Item	Type	CMV 10 type
Operation speed		0.05mm~1m/s(Button type)
Operating frequency		Electrical: 20 operations/min
Insulation resistance		100mΩ above(at 500VDC)
Contact resistance		15mΩ max. (initial value)
Withstand voltage	Non-continuous terminals	1000VAC, 50/60 Hz for 1 minute
	current-carrying and non-current-carrying metal parts, Between terminal and earthing	1500VAC, 50/60 Hz for 1 minute
Vibration	Misoperation	10 to 55Hz, 1.5mm pairs swing
Shock	Durable	Maximum 1000 m/S ² (100G)
	Misoperation	Maximum 200 m/S ² (100G)
Life	Electrical	More than 300000 times
Temperature		Using: -20~+70 °C (With no icing)
Humidity		(+5~+35 °C) Below 85% RH

Operating Characteristics

Models	CMV100D	CMV101D	CMV102D	CMV103D	CMV104D	CMV105D	CMV106D
OF(Max)	2.4N	1.23N	2.4N	1.23N	2.7N	0.69N	1.2N
RF(Min)	0.49N	0.14N	0.49N	0.14N	0.49N	0.06N	0.14N
PT(Max)	1.2mm	4.0mm	1.6mm	4.0mm	1.5mm	9.0mm	4.0mm
OT(Min)	1.0mm	1.6mm	0.8mm	1.6mm	0.8mm	2.0mm	1.5mm
MD(Max)	0.4mm	1.5mm	0.6mm	1.5mm	0.6mm	2.8mm	1.5mm
OP(mm.)	14.7 ± 0.4mm	15.2 ± 1.2mm	15.2 ± 0.5mm	20.7 ± 1.2mm	20.7 ± 0.6mm	15.2 ± 3mm	18.7 ± 1.2mm

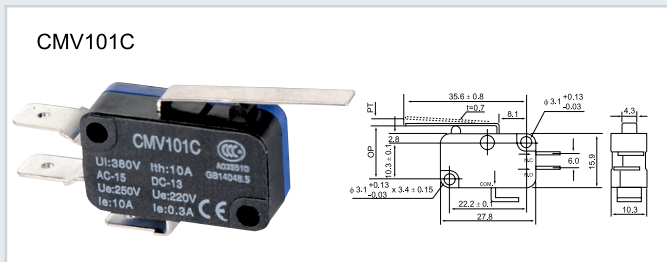
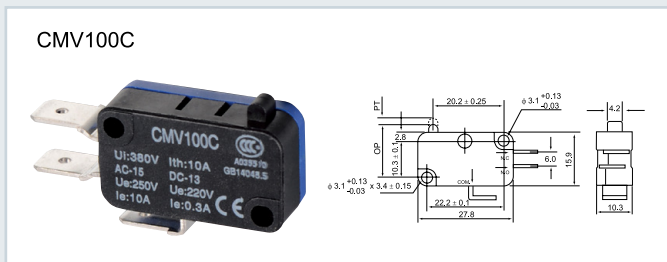

Appearance and Dimension

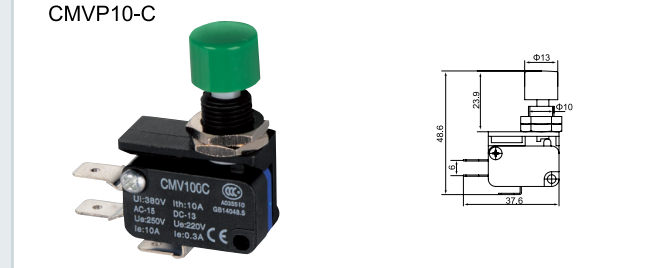
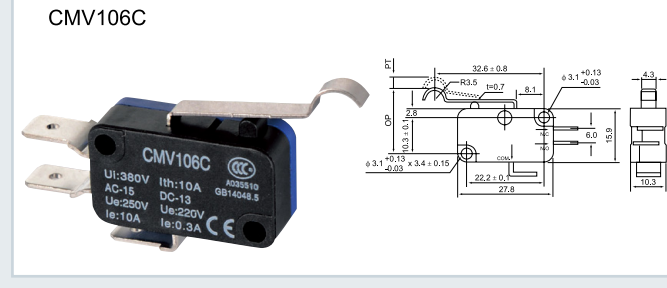
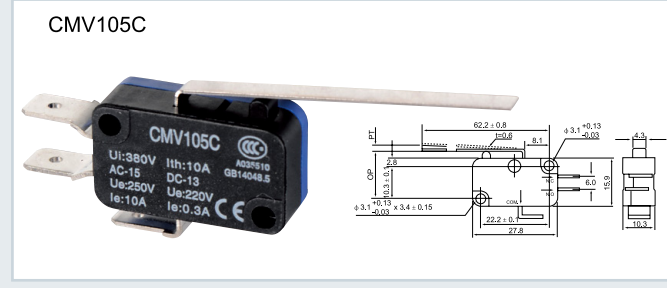
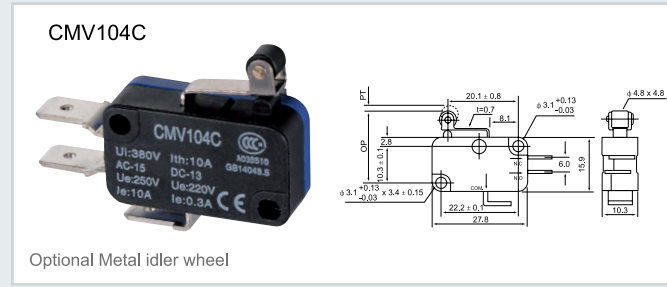
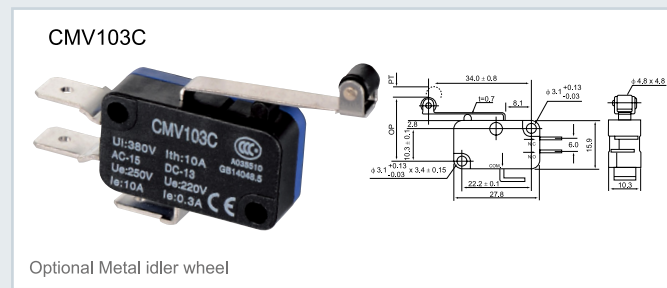
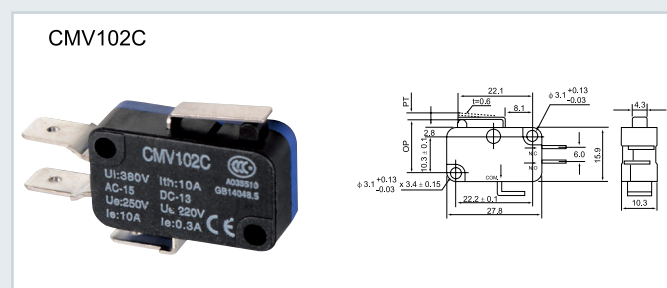
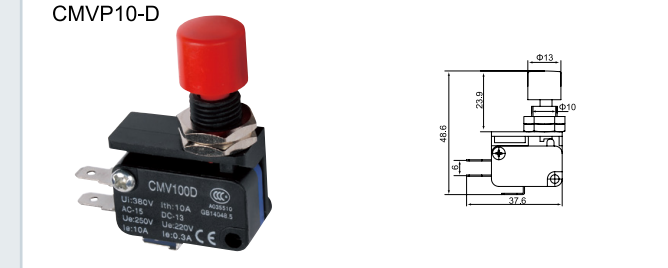
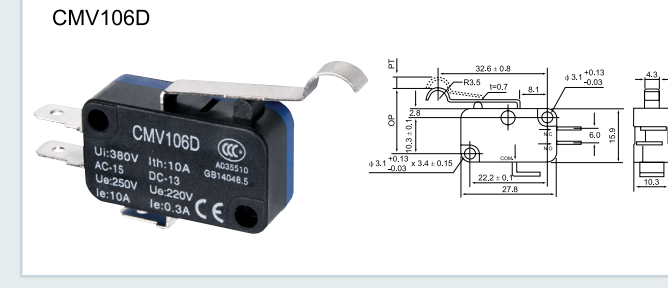
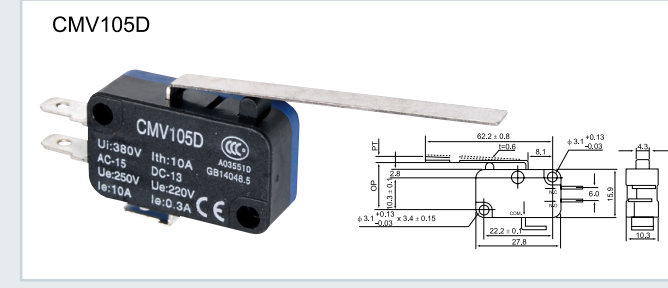
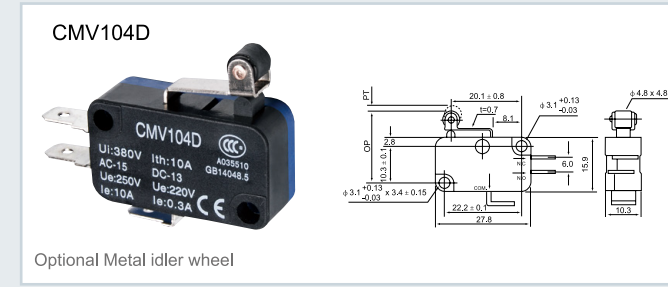
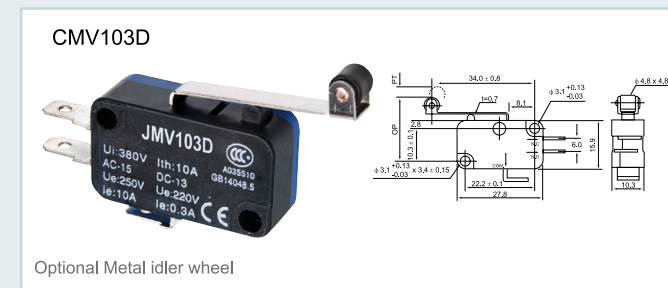
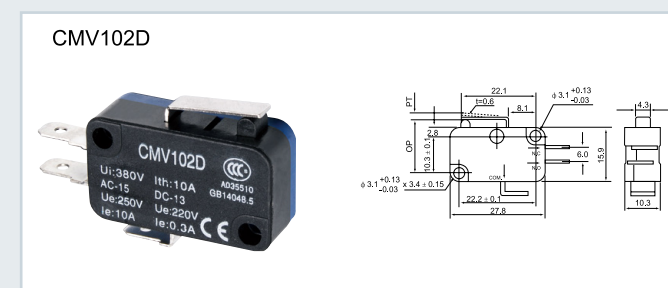



Ratings

Item	Rated Voltage	Noninductive Load (A)				Inductive Load (A)				Inrush Current	
		Resistance Load		Lamp Load		Inductive Load		Motor Load			
Spec.		NC	NO	NC	NO	NC	NO	NC	NO	NC	NO
16A	250VAC	16	2	10	3	40 max.					
	8VDC	16	4	10	6						
	30VDC	10	4	10	4						
	125VDC	0.6	0.1	0.6	0.1						
	250VDC	0.3	0.05	0.3	0.05						

Specifications

Item	Type	CMV 16 type
Operation speed		0.05mm~1m/s(Button type)
Operating frequency		Electrical: 20 operations/min
Insulation resistance		100mΩ above(at 500VDC)
Contact resistance		15mΩ max. (initial value)
Withstand voltage	Non-continuous terminals	1000VAC, 50/60 Hz for 1 minute
	current-carrying and non-current-carrying metal parts. Between terminal and earthing	2000VAC, 50/60 Hz for 1 minute
Vibration	Misoperation	10 to 55Hz, 1.5mm pairs swing
Shock	Durable	Maximum 1000 m/S ² (100G)
	Misoperation	Maximum 200 m/S ² (100G)
Life	Electrical	More than 300000 times
Temperature		Using: -20~+70°C (With no icing)
Humidity		(+5~+35°C)Below 85% RH

Model Number Structure

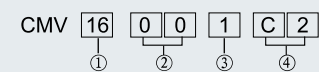

Item	Code	Description
① Rated Current	16	16A
② Head and driving rod	00	Button type
	01	Long handle type
	02	Short shank type
	03	Long pulley type
	04	Short pulley type
	05	Longer handle type
③ Contact form	1	1NO/1NC
	2	1NC
	3	1NO
③ Terminal specifications	C	#250 terminal
	C2	#187 terminal

Operating Characteristics

Model	CMV16	CMV16001C2	CMV16011C2	CMV16021C	CMV16031C2	CMV16041C2	CMV16051C2	CMV16061C
Operating force	PT(Max.)	2.4N	1.23N	2.4N	1.23N	2.7N	0.69N	1.2N
Release force	RF(Min.)	0.49N	0.14N	0.49N	0.14N	0.49N	0.06N	0.14N
Pre-travel	PT(Max.)	1.2mm	4.0mm	1.6mm	4.0mm	1.5mm	9.0mm	4.0mm
Over travel	OT(Min.)	1.0mm	1.6mm	0.8mm	1.6mm	0.8mm	2.0mm	1.5mm
Movement differential	MD(Max.)	0.4mm	1.5mm	0.6mm	1.5mm	0.6mm	2.8mm	1.5mm
Operating position	OP(mm.)	14.7 ± 0.4mm	15.2 ± 1.2mm	15.2 ± 0.5mm	20.7 ± 1.2mm	20.7 ± 0.6mm	15.2 ± 3mm	18.7 ± 1.2mm

Appearance and Dimension

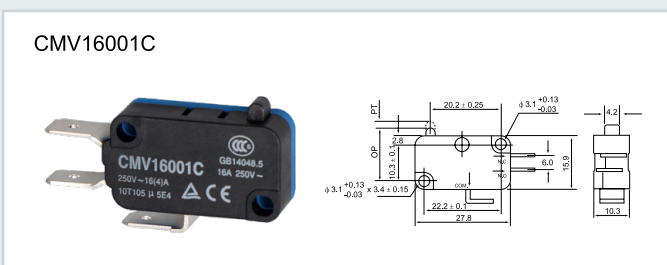
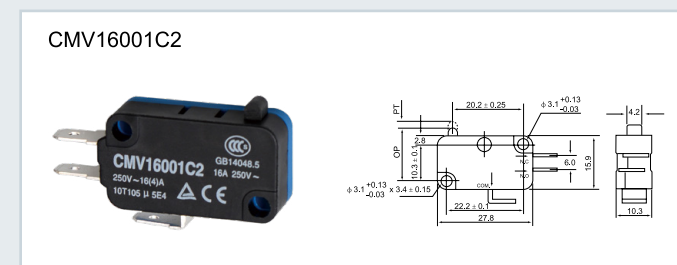

Appearance and Dimension

