

## Sensor Division

CJY Proximity Sensor Cylindrical Type	E01-09
CJY-T Proximity Sensor Cylindrical Connector Type	E10-16
CJY-R Proximity Sensor Cylindrical Cable Connector Type	E17-23
CJY □ S Long Distance Proximity Sensor Cylindrical Type	E24-27
CJY □ S-T Long Distance Proximity Sensor Cylindrical Connector Type	E28-31
CJY □ S-R Long Distance Proximity Sensor Cylindrical Cable Connector Type	E32-35
CJF Proximity Sensor Square Type	E36-42
CJF Proximity Sensor Flat Type	E43-45
CJF Proximity Sensor Cylindrical Type	E46-50
CJF Long Distance Proximity Sensor Flat Type	E51-53
CRY Capacitive Proximity Sensor	E54-56
CMY Analog Proximity Sensor	E57-58
CHY Hall Sensor	E59-60
CXY Magnetic Sensor	E61-62
CGY Photoelectric Sensor Cylindrical Type	E63-68
CGF Photoelectric Sensor Square Type	E69-78
CGU Photoelectric Sensor U Type	E79-82
Sensor Accessories	E83







Features

- Orange mark for standard type
- Light green mark for high-end type
- Inside surge protection, reverse polarity protection
- Long use-life cycle and high reliability, easy install, economic price
- Red LED status indication, easy to confirm work situation
- Protection structure IP67(IEC standard)
- Replaceable for limit switches
- Exclusively designed IC for improving anti-jamming capability

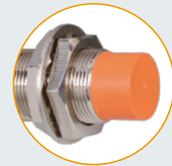

■ Orange

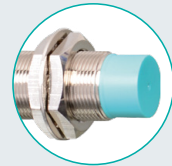

■ Light green

Model Number Structure

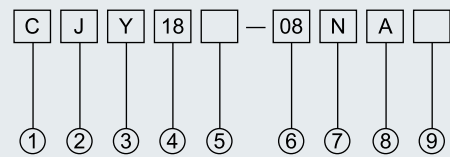

Item	Code	Description
① Company code	c	Company code
② Product name	J	Inductive proximity sensor
③ Shape of shell	Y	Cylinder-shaped
④ Dimension code	18	18=M18
⑤ Product type	Without	Without =High-end type (Light green head)
	E	E =Standard type (Orange head)
⑥ Detection distance	08	08=8mm
⑦ Output mode	K	AC 2wires
	L	DC 2wires
	P	PNP 3wires
	N	NPN 3wires
⑧ Output state	A	NO
	B	NC
	C	NO+NC
⑨ Connection	Without	Without: Lead wire
	T	Plug-in
	R	Wiring leads Plug-in

Specifications

DC 3-wire type

Model	High-end type	CJY04-01NA CJY04-01NB CJY04-01PA CJY04-01PB	CJY05-01NA CJY05-01NB CJY05-01PA CJY05-01PB	CJY06-01NA CJY06-01NB CJY06-01PA CJY06-01PB	CJY6.5-1.5NA CJY6.5-1.5NB CJY6.5-1.5PA CJY6.5-1.5PB
	Standard type	/	/	/	/
Sensing distance		1mm	1mm	1mm	1.5mm
Hysteresis	Max. 10% of sensing distance				
Standard sensing target		6 × 6 × 1mm (Iron)	7 × 7 × 1mm (Iron)	8 × 8 × 1mm (Iron)	8 × 8 × 1.5mm (Iron)
Setting distance		0~0.8mm	0~0.8mm	0~1.0mm	0~6.5mm
Power supply (Operating voltage)	12-24VDC (10-30VDC)				
Leakage current	Max.10mA				
Response frequency (*1)		1500Hz	1500Hz	1000Hz	1000Hz
Residual voltage (*2)	Max. 1.0V				
Affection by Temp.	Max. ± 10% for sensing distance at ambient temperature 20℃				
Control output	Max. 200mA				
Insulation resistance	Min. 50MΩ(at 500VDC megger)				
Dielectric strength	1500VAC 50/60Hz for 1minute				
Vibration	1mm amplitude at frequency of 10 to 55Hz(for 1 min.) in each of X, Y, Z directions for 2 hours				
Shock	500m/s <sup>2</sup> (approx. 50G) X, Y, Z directions for 3 times				
Indicator	Operation indicator(red LED)				
Ambient temperature	-25~+70℃ (No icing)				
Storage temperature	-30~+80℃ (No icing)				
Ambient humidity	35~95%RH (No condensation)				
Protection circuit	Surge protection circuit, Reverse polarity protection circuit, Overcurrent protection circuit				
Material	Case/Nut: Nickel plated Brass, Washer: Nickel plated Iron, Sensing surface: PBT,Standard cable(Grey): Polyvinyl chloride(PVC), Oil resistant cable(Black): Oil resistant Polyvinyl chloride(PVC)				
Cable	φ 2.8, 3P, 2m AWG22, Core diameter: 0.1mm, Number of cores: 22, Insulator diameter: φ 1.25				
Protection	IP67				

(\*1): The response frequency is the average value. The standard sensing target is used and the width is set as 2 times of the standard sensing target, 1/2 of the sensing distance for the distance.





Specifications

DC 3-wire type

Model	High-end type	CJY08-01NA CJY08-01NB CJY08-01PA CJY08-01PB	CJY08-02NA CJY08-02NB CJY08-02PA CJY08-02PB	CJY12-02NA CJY12-02NB CJY12-02NC CJY12-02PA CJY12-02PB CJY12-02PC	CJY12-04NA CJY12-04NB CJY12-04NC CJY12-04PA CJY12-04PB CJY12-04PC	CJY18-05NA CJY18-05NB CJY18-05NC CJY18-05PA CJY18-05PB CJY18-05PC	CJY18-08NA CJY18-08NB CJY18-08NC CJY18-08PA CJY18-08PB CJY18-08PC	CJY30-10NA CJY30-10NB CJY30-10NC CJY30-10PA CJY30-10PB CJY30-10PC	CJY30-15NA CJY30-15NB CJY30-15NC CJY30-15PA CJY30-15PB CJY30-15PC
	Standard type	CJY08E-01NA CJY08E-01NB CJY08E-01PA CJY08E-01PB	CJY08E-02NA CJY08E-02NB CJY08E-02PA CJY08E-02PB	CJY12E-02NA CJY12E-02NB CJY12E-02NC CJY12E-02PA CJY12E-02PB CJY12E-02PC	CJY12E-04NA CJY12E-04NB CJY12E-04NC CJY12E-04PA CJY12E-04PB CJY12E-04PC	CJY18E-05NA CJY18E-05NB CJY18E-05NC CJY18E-05PA CJY18E-05PB CJY18E-05PC	CJY18E-08NA CJY18E-08NB CJY18E-08NC CJY18E-08PA CJY18E-08PB CJY18E-08PC	CJY30E-10NA CJY30E-10NB CJY30E-10NC CJY30E-10PA CJY30E-10PB CJY30E-10PC	CJY30E-15NA CJY30E-15NB CJY30E-15NC CJY30E-15PA CJY30E-15PB CJY30E-15PC
Sensing distance	1mm	2mm	2mm	4mm	5mm	8mm	10mm	15mm	
Hysteresis	Max. 10% of sensing distance								
Standard sensing target	8 × 8 × 1mm (Iron)		12 × 12 × 1mm (Iron)		18 × 18 × 1mm (Iron)	25 × 25 × 1mm (Iron)	30 × 30 × 1mm (Iron)	45 × 45 × 1mm (Iron)	
Setting distance	0~0.8mm	0~1.4mm	0~1.4mm	0~2.8mm	0~3.5mm	0~5.6mm	0~7mm	0~10.5mm	
Power supply (Operating voltage)	12-24VDC (10-30VDC)								
Leakage current	Max. 10mA								
Response frequency (*1)	1000Hz	1000Hz	1000Hz	500Hz	350Hz	400Hz(High-end) 350Hz(standard)	200Hz		
Residual voltage	Max. 1.0V								
Affection by Temp.	Max. ± 10% for sensing distance at ambient temperature 20 °C								
Control output	Max. 200mA								
Insulation resistance	Min. 50MΩ (at 500VDC megger)								
Dielectric strength	1500VAC 50/60Hz for 1minute								
Vibration	1mm amplitude at frequency of 10 to 55Hz(for 1 min.) in each of X, Y, Z directions for 2 hours								
Shock	500m/s <sup>2</sup> (approx. 50G) X, Y, Z directions for 3 times								
Indicator	Operation indicator(red LED)								
Ambient temperature	-25~+70 °C (No icing)								
Storage temperature	-30~+80 °C (No icing)								
Ambient humidity	35~95%RH (No condensation)								
Protection circuit	Surge protection circuit, Reverse polarity protection circuit, Overcurrent protection circuit								
Material	Case/Nut: Nickel plated Brass, Washer: Nickel plated Iron, Sensing surface: PBT,Standard cable(Grey): Polyvinyl chloride(PVC), Oil resistant cable(Black): Oil resistant Polyvinyl chloride(PVC)								
Cable	High-end type	φ 2.8, 3P, 2m		φ 3.8, 3P,4P 2m		φ 4.8, 3P,4P 2m			
		(AWG22, Core diameter: 0.1mm, Number of cores: 22, Insulator diameter: φ 1.25)		(AWG22, Core diameter: 0.1mm, Number of cores: 25, Insulator diameter: φ 1.25)		(AWG22, Core diameter: 0.1mm, Number of cores: 30, Insulator diameter: φ 1.25)			
Cable	Standard type	φ 2.8, 3P, 1.5m		φ 3.8, 3P, 4P 1.5m		φ 4.8, 3P, 4P 1.5m			
		(AWG22, Core diameter: 0.1mm, Number of cores: 22, Insulator diameter: φ 1.25)		(AWG22, Core diameter: 0.1mm, Number of cores: 25, Insulator diameter: φ 1.25)		(AWG22, Core diameter: 0.1mm, Number of cores: 30, Insulator diameter: φ 1.25)			
Protection	IP67								

(\*1): The response frequency is the average value. The standard sensing target is used and the width is set as 2 times of the standard sensing target, 1/2 of the sensing distance for the distance.

Specifications

DC 2-wire type

Model	High-end type	CJY08-01LA CJY08-01LB	CJY08-02LA CJY08-02LB	CJY12-02LA CJY12-02LB	CJY12-04LA CJY12-04LB	CJY18-05LA CJY18-05LB	CJY18-08LA CJY18-08LB	CJY30-10LA CJY30-10LB	CJY30-15LA CJY30-15LB
	Standard type	CJY08E-01LA CJY08E-01LB	CJY08E-02LA CJY08E-02LB	CJY12E-02LA CJY12E-02LB	CJY12E-04LA CJY12E-04LB	CJY18E-05LA CJY18E-05LB	CJY18E-08LA CJY18E-08LB	CJY30E-10LA CJY30E-10LB	CJY30E-15LA CJY30E-15LB
Sensing distance	1mm	2mm	2mm	4mm	5mm	8mm	10mm	15mm	
Hysteresis	Max. 10% of sensing distance								
Standard sensing target	8 × 8 × 1mm (Iron)		12 × 12 × 1mm (Iron)		18 × 18 × 1mm (Iron)	25 × 25 × 1mm (Iron)	30 × 30 × 1mm (Iron)	45 × 45 × 1mm (Iron)	
Setting distance	0~0.8mm	0~1.4mm	0~1.4mm	0~2.8mm	0~3.5mm	0~5.6mm	0~7mm	0~10.5mm	
Power supply (Operating voltage)	12-24VDC (10-30VDC)								
Leakage current	Max.0.6mA								
Response frequency (*1)	1000Hz	1000Hz	1000Hz	500Hz	350Hz	350Hz	200Hz		
Residual voltage	Max. 3.5V								
Affection by Temp.	Max. ± 10% for sensing distance at ambient temperature 20 °C								
Control output	Max. 200mA								
Insulation resistance	Min. 50MΩ (at 500VDC megger)								
Dielectric strength	1500VAC 50/60Hz for 1minute								
Vibration	1mm amplitude at frequency of 10 to 55Hz(for 1 min.) in each of X, Y, Z directions for 2 hours								
Shock	500m/s <sup>2</sup> (approx. 50G) X, Y, Z directions for 3 times								
Indicator	Operation indicator(red LED)								
Ambient temperature	-25~+70 °C (No icing)								
Storage temperature	-30~+80 °C (No icing)								
Ambient humidity	35~95%RH (No condensation)								
Protection circuit	Surge protection circuit								
Material	Case/Nut: Nickel plated Brass, Washer: Nickel plated Iron, Sensing surface: PBT, Standard cable(Gray): Polyvinyl chloride(PVC), Oil resistant cable(Black): Oil resistant Polyvinyl chloride(PVC)								
Cable	High-end type	φ 2.8, 2P, 2m		φ 3.8, 2P, 2m		φ 4.8, 2P, 2m			
		(AWG22, Core diameter: 0.1mm, Number of cores: 22, Insulator diameter: φ 1.25)		(AWG22, Core diameter: 0.1mm, Number of cores: 25, Insulator diameter: φ 1.25)		(AWG22, Core diameter: 0.1mm, Number of cores: 30, Insulator diameter: φ 1.25)			
Cable	Standard type	φ 2.8, 2P, 1.5m		φ 3.8, 2P, 1.5m		φ 4.8, 2P, 1.5m			
		(AWG22, Core diameter: 0.1mm, Number of cores: 22, Insulator diameter: φ 1.25)		(AWG22, Core diameter: 0.1mm, Number of cores: 25, Insulator diameter: φ 1.25)		(AWG22, Core diameter: 0.1mm, Number of cores: 30, Insulator diameter: φ 1.25)			
Protection	IP67								

(\*1): The response frequency is the average value. The standard sensing target is used and the width is set as 2 times of the standard sensing target, 1/2 of the sensing distance for the distance.



Specifications

AC 2-wire type

Model	High-end type	/	CJY12-04KA CJY12-04KB	CJY18-05KA CJY18-05KB	CJY18-08KA CJY18-08KB	CJY30-10KA CJY30-10KB	CJY30-15KA CJY30-15KB
	Standard type	CJY12E-02KA CJY12E-02KB	CJY12E-04KA CJY12E-04KB	CJY18E-05KA CJY18E-05KB	CJY18E-08KA CJY18E-08KB	CJY30E-10KA CJY30E-10KB	CJY30E-15KA CJY30E-15KB
Sensing distance	2mm	4mm	5mm	8mm	10mm	15mm	
Hysteresis	Max. 10% of sensing distance						
Standard sensing target	12 × 12 × 1mm (Iron)		18 × 18 × 1mm (Iron)	25 × 25 × 1mm (Iron)	30 × 30 × 1mm (Iron)	45 × 45 × 1mm (Iron)	
Setting distance	0~1.4mm	0~2.8mm	0~3.5mm	0~5.6mm	0~7mm	0~10.5mm	
Power supply (Operating voltage)	24-250VAC() 90-250VAC ()						
Leakage current	Max. 10mA						
Response frequency (*1)	20Hz						
Residual voltage	Max. 10V						
Affection by Temp.	Max. ± 10% for sensing distance at ambient temperature 20℃						
Control output	Max. 200mA						
Insulation resistance	Min. 50MΩ (at 500VDC megger)						
Dielectric strength	1500VAC 50/60Hz for 1minute						
Vibration	1mm amplitude at frequency of 10 to 55Hz(for 1 min.) in each of X, Y, Z directions for 2 hours						
Shock	500m/s <sup>2</sup> (approx. 50G) X, Y, Z directions for 3 times						
Indicator	Operation indicator(red LED)						
Ambient temperature	-25~+70℃ (No icing)						
Storage temperature	-30~+80℃ (No icing)						
Ambient humidity	35~95%RH (No condensation)						
Protection circuit	Surge protection current						
Material	Case/Nut: Nickel plated Brass, Washer: Nickel plated Iron, Sensing surface: PBT, Standard cable(Gray): Polyvinyl chloride(PVC), Oil resistant cable(Black): Oil resistant Polyvinyl chloride(PVC)						
Cable	High-end type	φ 3.8, 2P, 2m		φ 4.8, 2P, 2m			
	Standard type	(AWG22, Core diameter: 0.1mm, Number of cores: 25, Insulator diameter: φ 1.25)		(AWG22, Core diameter: 0.1mm, Number of cores: 30, Insulator diameter: φ 1.25)			
Protection	High-end type	φ 3.8, 2P, 1.5m		φ 4.8, 2P, 1.5m			
	Standard type	(AWG22, Core diameter: 0.1mm, Number of cores: 25, Insulator diameter: φ 1.25)		(AWG22, Core diameter: 0.1mm, Number of cores: 30, Insulator diameter: φ 1.25)			

(\*1): The response frequency is the average value. The standard sensing target is used and the width is set as 2 times of the standard sensing target, 1/2 of the sensing distance for the distance.

Appearance and Dimension

<p>CJY04-01</p>
<p>CJY05-01</p>
<p>CJY06-01</p>
<p>CJY6.5-1.5</p>
<p>CJY08-01</p>
<p>CJY08-02</p>





Appearance and Dimension

CJY12-02			
CJY12-04			
CJY18-05			
CJY18-08			
CJY30-10			
CJY30-15			

Appearance and Dimension

CJY08E-01			
CJY08E-02			
CJY12E-02			
CJY12E-04			
CJY18E-05			
CJY18E-08			
CJY30E-10			
CJY30E-15			





Control Output Diagram

DC 2-wire type

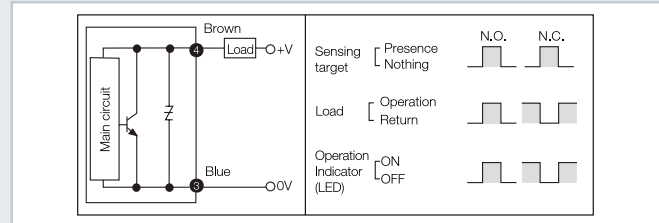

DC 3-wire type

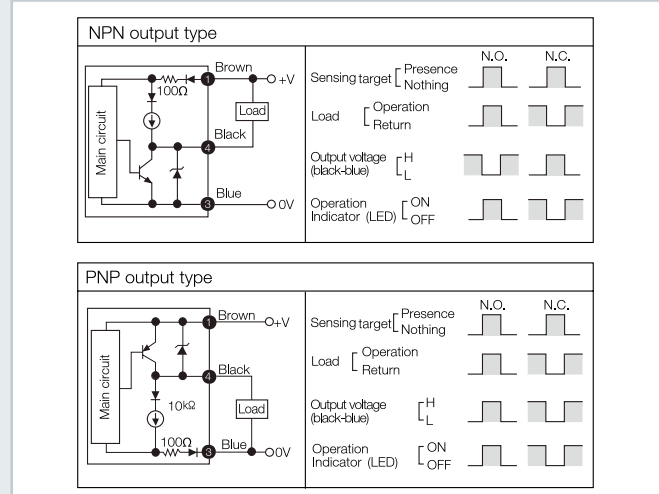

AC 2-wire type

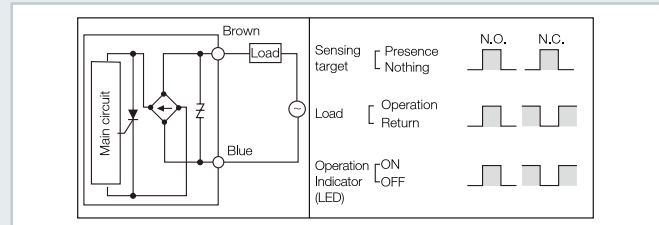

Connections

DC 2-wire type

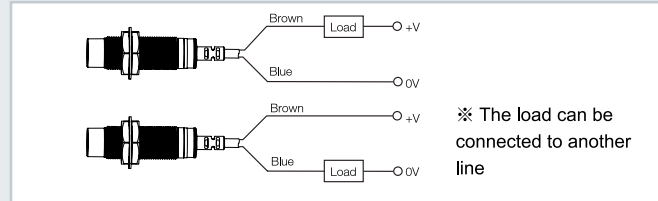

DC 3-wire type

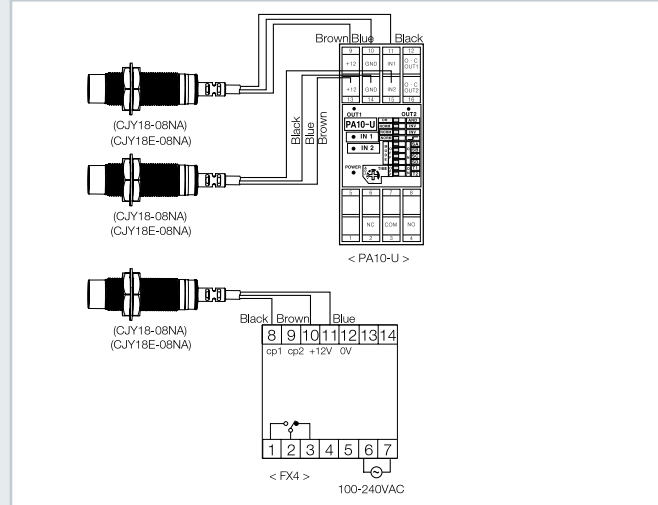

AC 2-wire type

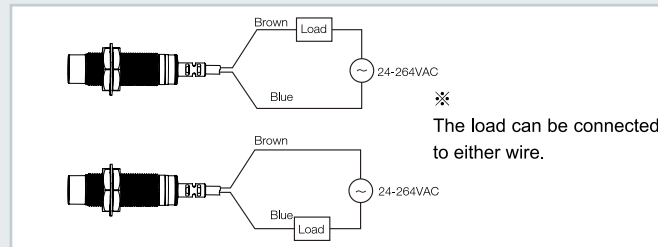

Proper Usage

Mutual-interference

When several proximity sensors are mounted close to one another a malfunction of the sensor may be caused due to mutual interference. Therefore, be sure to provide a minimum distance between the two sensors as below chart indicates.

Influence by surrounding metals

When sensors are mounted on metallic panel, you must prevent the sensors from being affected by any metallic object except target. Therefore, be sure to provide a minimum distance as below chart indicates.

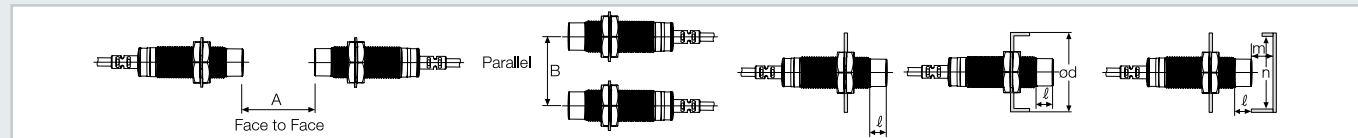

Item	Model	CJY08-01 CJY08E-01	CJY08-02 CJY08E-02	CJY12-02 CJY12E-02	CJY12-04 CJY12E-04	CJY18-05 CJY18E-05	CJY18-08 CJY18E-08	CJY30-10 CJY30E-10	CJY30-15 CJY30E-15
A		9	12	12	24	30	48	60	90
B		16	24	24	36	36	54	60	90
l		0	8	0	11	0	14	0	15
φ d		8	24	12	36	18	54	30	90
m		4.5	6	6	12	15	24	30	45
n		12	24	18	36	27	54	45	90



Features

- Orange mark for standard type
- Light green mark for high-end type
- Exclusively designed IC for improving anti-jamming capability
- Inside surge protection, reverse polarity protection, overcurrent protection
- Long use-life cycle and high reliability, easy install, economic price
- Red LED status indication, easy to confirm work situation
- Protection structure IP65(IEC standard)
- Replaceable for limit switches

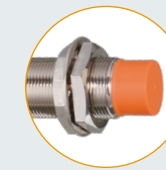

Orange

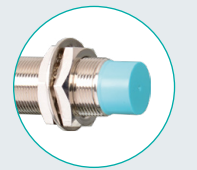

Light green

Model Number Structure

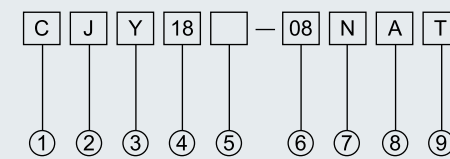

Item	Code	Description
① Company code	C	Company code
② Product name	J	Inductive proximity sensor
③ Shape of shell	Y	Cylinder-shaped
④ Dimension code	18	18=M18
⑤ Product type	Without	Without = High-end type (Light green head)
	E	E=Standard type (Orange head)
⑥ Detection distance	08	08=8mm
	K	AC 2wires
	L	DC 2wires
⑦ Output mode	P	PNP 3wires
	N	NPN 3wires
	A	NO
⑧ Output state	B	NC
	C	NO+NC
	Without	Without: Lead wire
⑨ Connection	T	Plug-in
	R	Wiring leads Plug-in





Specifications

DC 3-wire type

Model	High-end type	CJY12-02NAT CJY12-02NBT CJY12-02NCT CJY12-02PAT CJY12-02PBT CJY12-02PCT	CJY12-04NAT CJY12-04NBT CJY12-04NCT CJY12-04PAT CJY12-04PBT CJY12-04PCT	CJY18-05NAT CJY18-05NBT CJY18-05NCT CJY18-05PAT CJY18-05PBT CJY18-05PCT	CJY18-08NAT CJY18-08NBT CJY18-08NCT CJY18-08PAT CJY18-08PBT CJY18-08PCT	CJY30-10NAT CJY30-10NBT CJY30-10NCT CJY30-10PAT CJY30-10PBT CJY30-10PCT	CJY30-15NAT CJY30-15NBT CJY30-15NCT CJY30-15PAT CJY30-15PBT CJY30-15PCT
	Standard type	CJY12E-02NAT CJY12E-02NBT CJY12E-02NCT CJY12E-02PAT CJY12E-02PBT CJY12E-02PCT	CJY12E-04NAT CJY12E-04NBT CJY12E-04NCT CJY12E-04PAT CJY12E-04PBT CJY12E-04PCT	CJY18E-05NAT CJY18E-05NBT CJY18E-05NCT CJY18E-05PAT CJY18E-05PBT CJY18E-05PCT	CJY18E-08NAT CJY18E-08NBT CJY18E-08NCT CJY18E-08PAT CJY18E-08PBT CJY18E-08PCT	CJY30E-10NAT CJY30E-10NBT CJY30E-10NCT CJY30E-10PAT CJY30E-10PBT CJY30E-10PCT	CJY30E-15NAT CJY30E-15NBT CJY30E-15NCT CJY30E-15PAT CJY30E-15PBT CJY30E-15PCT
Sensing distance	2mm	4mm	5mm	8mm	10mm	15mm	
Hysteresis	Max. 10% of sensing distance						
Standard sensing target	12 × 12 × 1mm (Iron)		18 × 18 × 1mm (Iron)	25 × 25 × 1mm (Iron)	30 × 30 × 1mm (Iron)	45 × 45 × 1mm (Iron)	
Setting distance	0~1.4mm	0~2.8mm	0~3.5mm	0~5.6mm	0~7mm	0~10.5mm	
Power supply (Operating voltage)	12-24VDC (10-30VDC)						
Leakage current	Max.10mA						
Response frequency (※1)	1000Hz	500Hz	500Hz	350Hz	350Hz(High-end) 400Hz(standard)	200Hz	
Residual voltage	Max. 1.0V						
Affection by Temp.	Max. ± 10% for sensing distance at ambient temperature 20℃						
Control output	Max. 200mA						
Insulation resistance	Min. 50MΩ (at 500VDC megger)						
Dielectric strength	1500VAC 50/60Hz for 1minute						
Vibration	1mm amplitude at frequency of 10 to 55Hz(for 1 min.) in each of X, Y, Z directions for 2 hours						
Shock	500m/s <sup>2</sup> (approx. 50G) X, Y, Z directions for 3 times						
Indicator	Operation indicator(red LED)						
Ambient temperature	-25~+70℃ (No icing)						
Storage temperature	-30~+80℃ (No icing)						
Ambient humidity	35~95%RH (No condensation)						
Protection circuit	Surge protection circuit, Reverse polarity protection circuit, Overcurrent protection circuit						
Material	Case/Nut: Nickel plated Brass, Washer: Nickel plated Iron, Sensing surface: PBT						
Protection	IP65						

(※1): The response frequency is the average value. The standard sensing target is used and the width is set as 2 times of the standard sensing target, 1/2 of the sensing distance for the distance.

Specifications

DC 2-wire type

Model	High-end type	CJY12-02LAT CJY12-02LBT	CJY12-04LAT CJY12-04LBT	CJY18-05LAT CJY18-05LBT	CJY18-08LAT CJY18-08LBT	CJY30-10LAT CJY30-10LBT	CJY30-15LAT CJY30-15LBT
	Standard type	CJY12E-02LAT	CJY12E-04LAT	CJY18E-05LAT	CJY18E-08LAT	CJY30E-10LAT	CJY30E-15LAT
Sensing distance	2mm	4mm	5mm	8mm	10mm	15mm	
Hysteresis	Max. 10% of sensing distance						
Standard sensing target	12 × 12 × 1mm (Iron)		18 × 18 × 1mm (Iron)	25 × 25 × 1mm (Iron)	30 × 30 × 1mm (Iron)	45 × 45 × 1mm (Iron)	
Setting distance	0~1.4mm	0~2.8mm	0~3.5mm	0~5.6mm	0~7mm	0~10.5mm	
Power supply (Operating voltage)	12-24VDC (10-30VDC)						
Leakage current	Max.0.6mA						
Response frequency (※1)	1000Hz	500Hz	500Hz	350Hz	350Hz	200Hz	
Residual voltage	Max. 3.5V						
Affection by Temp.	Max. ± 10% for sensing distance at ambient temperature 20℃						
Control output	Max. 200mA						
Insulation resistance	Min. 50MΩ (at 500VDC megger)						
Dielectric strength	1500VAC 50/60Hz for 1minute						
Vibration	1mm amplitude at frequency of 10 to 55Hz(for 1 min.) in each of X, Y, Z directions for 2 hours						
Shock	500m/s <sup>2</sup> (approx. 50G) X, Y, Z directions for 3 times						
Indicator	Operation indicator(red LED)						
Ambient temperature	-25~+70℃ (No icing)						
Storage temperature	-30~+80℃ (No icing)						
Ambient humidity	35~95%RH (No condensation)						
Protection circuit	Surge protection circuit						
Material	Case/Nut: Nickel plated Brass, Washer: Nickel plated Iron, Sensing surface: PBT						
Protection	IP65						

(※1): The response frequency is the average value. The standard sensing target is used and the width is set as 2 times of the standard sensing target, 1/2 of the sensing distance for the distance.



Specifications

AC 2-wire type

Model	High-end type	/	CJY12-04KAT CJY12-04KBT	CJY18-05KAT CJY18-05KBT	CJY18-08KAT CJY18-08KBT	CJY30-10KAT CJY30-10KBT	CJY30-15KAT CJY30-15KBT
	Standard type	CJY12E-02KAT CJY12E-02KBT	CJY12E-04KAT CJY12E-04KBT	CJY18E-05KAT CJY18E-05KBT	CJY18E-08KAT CJY18E-08KBT	CJY30E-10KAT CJY30E-10KBT	CJY30E-15KAT CJY30E-15KBT
Sensing distance	2mm	4mm	5mm	8mm	10mm	15mm	
Hysteresis	Max. 10% of sensing distance						
Standard sensing target	12 × 12 × 1mm (Iron)		18 × 18 × 1mm (Iron)	25 × 25 × 1mm (Iron)	30 × 30 × 1mm (Iron)	45 × 45 × 1mm (Iron)	
Setting distance	0~1.4mm	0~2.8mm	0~3.5mm	0~5.6mm	0~7mm	0~10.5mm	
Power supply (Operating voltage)	90-250VAC						
Leakage current	Max. 10mA						
Response frequency (*1)	20Hz						
Residual voltage	Max. 10V						
Affection by Temp.	Max. ± 10% for sensing distance at ambient temperature 20°C						
Control output	Max. 200mA						
Insulation resistance	Min. 50MΩ (at 500VDC megger)						
Dielectric strength	1500VAC 50/60Hz for 1minute						
Vibration	1mm amplitude at frequency of 10 to 55Hz(for 1 min.) in each of X, Y, Z directions for 2 hours						
Shock	500m/s <sup>2</sup> (approx. 50G) X, Y, Z directions for 3 times						
Indicator	Operation indicator(red LED)						
Ambient temperature	-25~+70°C (No icing)						
Storage temperature	-30~+80°C (No icing)						
Ambient humidity	35~95%RH (No condensation)						
Protection circuit	Surge protection current						
Material	Case/Nut: Nickel plated Brass, Washer: Nickel plated Iron, Sensing surface: PBT						
Protection	IP65						

(\*1): The response frequency is the average value. The standard sensing target is used and the width is set as 2 times of the standard sensing target, 1/2 of the sensing distance for the distance.

Appearance and Dimension

<p>CJY12-02T</p>		<p>NA NB PA PB LA LB Following chart</p>	<p>NC PC Following chart</p>
<p>CJY12-04T</p>		<p>NA NB PA PB LA LB Following chart</p>	<p>NC PC KA KB Following chart</p>
<p>CJY18-05T</p>		<p>NA NB PA PB LA LB Following chart</p>	<p>NC PC KA KB Following chart</p>
<p>CJY18-08T</p>		<p>NA NB PA PB LA LB Following chart</p>	<p>NC PC KA KB Following chart</p>
<p>CJY30-10T</p>		<p>NA NB PA PB LA LB Following chart</p>	<p>NC PC KA KB Following chart</p>
<p>CJY30-15T</p>		<p>NA NB PA PB LA LB Following chart</p>	<p>NC PC KA KB Following chart</p>



Appearance and Dimension

**CJY12E-02T**

**CJY12E-04T**

**CJY18E-05T**

**CJY18E-08T**

**CJY30E-10T**

**CJY30E-15T**

NA NB NC PA PB PC LA LB Following chart      KA KB Following chart

Control Output Diagram

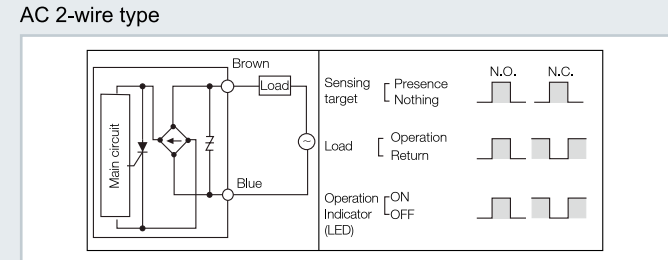
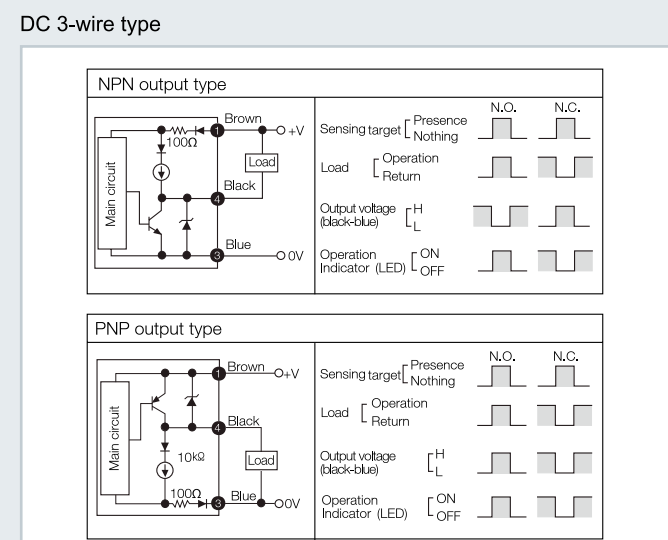
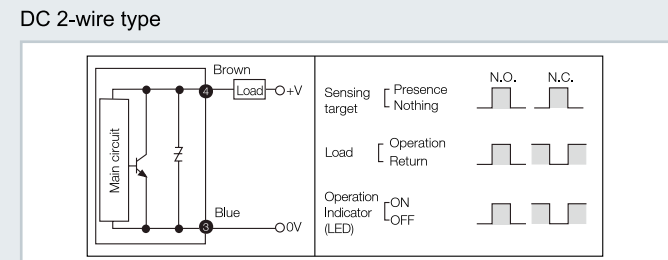

Wiring Diagram

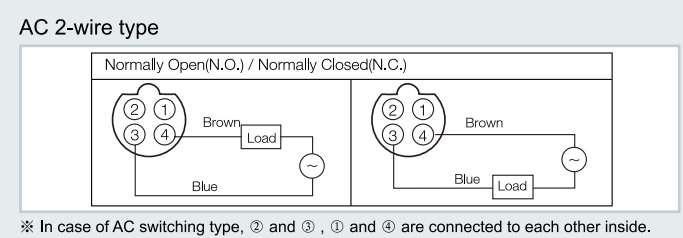
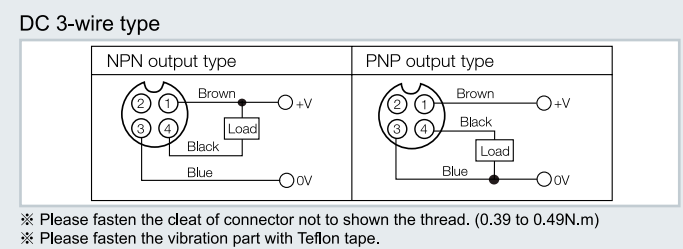
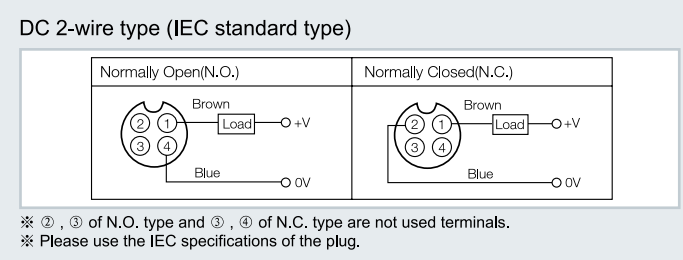
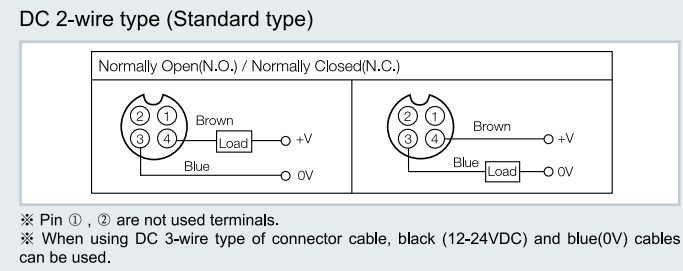

Proper Usage

**Mutual-interference**  
 When several proximity sensors are mounted close to one another a malfunction of the sensor may be caused due to mutual interference. Therefore, be sure to provide a minimum distance between the two sensors as below chart indicates.

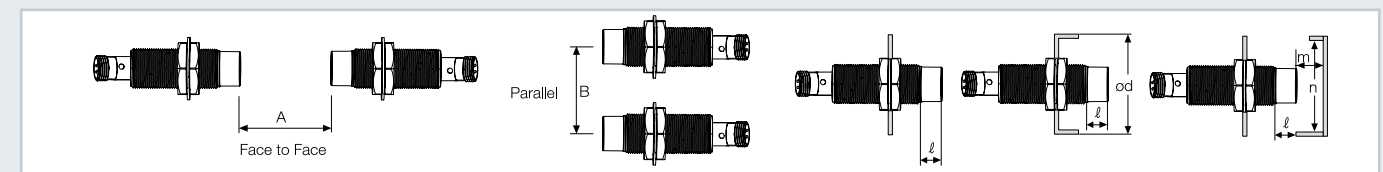

**Influence by surrounding metals**  
 When sensors are mounted on metallic panel, you must prevent the sensors from being affected by any metallic object except target. Therefore, be sure to provide a minimum distance as below chart indicates.

Model	CJY12-02T	CJY12-04T	CJY18-05T	CJY18-08T	CJY30-10T	CJY30-15T
Item	CJY12E-02T	CJY12E-04T	CJY18E-05T	CJY18E-08T	CJY30E-10T	CJY30E-15T
A	12	24	30	48	60	90
B	24	36	36	54	60	90
ℓ	0	11	0	14	0	15
φ d	12	36	18	54	30	90
m	6	12	15	24	30	45
n	18	36	27	54	45	90



Features

- Orange mark for standard type
- Light green mark for high-end type
- Exclusively designed IC for improving anti-jamming capability
- Inside surge protection, reverse polarity protection, overcurrent protection
- Long use-life cycle and high reliability, easy install, economic price
- Red LED status indication, easy to confirm work situation
- Protection structure IP67(IEC standard)
- Replaceable for limit switches

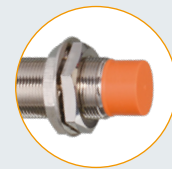

■ Orange

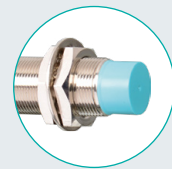

■ Light green

Model Number Structure

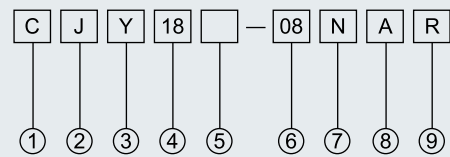

Item	Code	Description
① Company code	C	Company code
② Product name	J	Inductive proximity sensor
③ Shape of shell	Y	Cylinder-shaped
④ Dimension code	18	18=M18
⑤ Product type	Without	Without = High-end type (Light green head)
	E	E = Standard type (Orange head)
⑥ Detection distance	08	08=8mm
⑦ Output mode	K	AC 2wires
	L	DC 2wires
	P	PNP 3wires
	N	NPN 3wires
⑧ Output state	A	NO
	B	NC
	C	NO+NC
⑨ Connection	Without	Without: Lead wire
	T	Plug-in
	R	Wiring leads Plug-in

Specifications

DC 3-wire type

Model	High-end type	CJY12-02NAR CJY12-02NBR CJY12-02NCR CJY12-02PAR CJY12-02PBR CJY12-02PCR	CJY12-04NAR CJY12-04NBR CJY12-04NCR CJY12-04PAR CJY12-04PBR CJY12-04PCR	CJY18-05NAR CJY18-05NBR CJY18-05NCR CJY18-05PAR CJY18-05PBR CJY18-05PCR	CJY18-08NAR CJY18-08NBR CJY18-08NCR CJY18-08PAR CJY18-08PBR CJY18-08PCR	CJY30-10NAR CJY30-10NBR CJY30-10NCR CJY30-10PAR CJY30-10PBR CJY30-10PCR	CJY30-15NAR CJY30-15NBR CJY30-15NCR CJY30-15PAR CJY30-15PBR CJY30-15PCR
	Standard type	CJY12E-02NAR CJY12E-02NBR CJY12E-02NCR CJY12E-02PAR CJY12E-02PBR CJY12E-02PCR	CJY12E-04NAR CJY12E-04NBR CJY12E-04NCR CJY12E-04PAR CJY12E-04PBR CJY12E-04PCR	CJY18E-05NAR CJY18E-05NBR CJY18E-05NCR CJY18E-05PAR CJY18E-05PBR CJY18E-05PCR	CJY18E-08NAR CJY18E-08NBR CJY18E-08NCR CJY18E-08PAR CJY18E-08PBR CJY18E-08PCR	CJY30E-10NAR CJY30E-10NBR CJY30E-10NCR CJY30E-10PAR CJY30E-10PBR CJY30E-10PCR	CJY30E-15NAR CJY30E-15NBR CJY30E-15NCR CJY30E-15PAR CJY30E-15PBR CJY30E-15PCR
Sensing distance	2mm	4mm	5mm	8mm	10mm	15mm	
Hysteresis	Max. 10% of sensing distance						
Standard sensing target	12 × 12 × 1mm (Iron)		18 × 18 × 1mm (Iron)	25 × 25 × 1mm (Iron)	30 × 30 × 1mm (Iron)	45 × 45 × 1mm (Iron)	
Setting distance	0~1.4mm	0~2.8mm	0~3.5mm	0~5.6mm	0~7mm	0~10.5mm	
Power supply (Operating voltage)	12-24VDC (10-30VDC)						
Leakage current	Max.10mA						
Response frequency (*1)	1000Hz	500Hz	500Hz	350Hz	350Hz	200Hz	
Residual voltage	Max. 1.0V						
Affection by Temp.	Max. ± 10% for sensing distance at ambient temperature 20℃						
Control output	Max. 200mA						
Insulation resistance	Min. 50MΩ (at 500VDC megger)						
Dielectric strength	1500VAC 50/60Hz for 1minute						
Vibration	1mm amplitude at frequency of 10 to 55Hz(for 1 min.) in each of X, Y, Z directions for 2 hours						
Shock	500m/s <sup>2</sup> (approx. 50G) X, Y, Z directions for 3 times						
Indicator	Operation indicator(red LED)						
Ambient temperature	-25~+70℃ (No icing)						
Storage temperature	-30~+80℃ (No icing)						
Ambient humidity	35~95%RH (No condensation)						
Protection circuit	Surge protection circuit, Reverse polarity protection circuit, Overcurrent protection circuit						
Material	Case/Nut: Nickel plated Brass, Washer: Nickel plated Iron, Sensing surface: PBT, Standard cable(Gray): Polyvinyl chloride(PVC), Oil resistant cable(Black): Oil resistant Polyvinyl chloride(PVC)						
Cable	φ 3.8, 3P,4P 300mm, M12 connector			φ 4.8, 3P,4P 300mm, M12 connector			
Protection	IP67						

(\*1): The response frequency is the average value. The standard sensing target is used and the width is set as 2 times of the standard sensing target, 1/2 of the sensing distance for the distance.



## Specifications

DC 2-wire type

Model	CJY12-02LAR CJY12-02LBR	CJY12-04LAR CJY12-04LBR	CJY18-05LAR CJY18-05LBR	CJY18-08LAR CJY18-08LBR	CJY30-10LAR CJY30-10LBR	CJY30-15LAR CJY30-15LBR
Sensing distance	2mm	4mm	5mm	8mm	10mm	15mm
Hysteresis	Max. 10% of sensing distance					
Standard sensing target	12 × 12 × 1mm (Iron)		18 × 18 × 1mm (Iron)	25 × 25 × 1mm (Iron)	30 × 30 × 1mm (Iron)	45 × 45 × 1mm (Iron)
Setting distance	0~1.4mm	0~2.8mm	0~3.5mm	0~5.6mm	0~7mm	0~10.5mm
Power supply (Operating voltage)	12-24VDC (10-30VDC)					
Leakage current	Max.0.6mA					
Response frequency (*1)	1000Hz	500Hz	500Hz	350Hz	350Hz	200Hz
Residual voltage	Max. 3.5V					
Affection by Temp.	Max. ± 10% for sensing distance at ambient temperature 20℃					
Control output	Max. 200mA					
Insulation resistance	Min. 50MΩ (at 500VDC megger)					
Dielectric strength	1500VAC 50/60Hz for 1minute					
Vibration	1mm amplitude at frequency of 10 to 55Hz(for 1 min.) in each of X, Y, Z directions for 2 hours					
Shock	500m/s <sup>2</sup> (approx. 50G) X, Y, Z directions for 3 times					
Indicator	Operation indicator(red LED)					
Ambient temperature	-25~+70℃ (No icing)					
Storage temperature	-30~+80℃ (No icing)					
Ambient humidity	35~95%RH (No condensation)					
Protection circuit	Surge protection circuit, Overcurrent protection circuit					
Material	Case/Nut: Nickel plated Brass, Washer: Nickel plated Iron, Sensing surface: PBT, Standard cable(Gray): Polyvinyl chloride(PVC), Oil resistant cable(Black): Oil resistant Polyvinyl chloride(PVC)					
Cable	φ 3.8, 2P, 300mm, M12 connector		φ 4.8, 2P, 300mm, M12 connector			
Protection	IP67					

(\*1): The response frequency is the average value. The standard sensing target is used and the width is set as 2 times of the standard sensing target, 1/2 of the sensing distance for the distance.

## Specifications

AC 2-wire type

Model	CJY12-02KAR CJY12-02KBR	CJY12-04KAR CJY12-04KBR	CJY18-05KAR CJY18-05KBR	CJY18-08KAR CJY18-08KBR	CJY30-10KAR CJY30-10KBR	CJY30-15KAR CJY30-15KBR
Sensing distance	2mm	4mm	5mm	8mm	10mm	15mm
Hysteresis	Max. 10% of sensing distance					
Standard sensing target	12 × 12 × 1mm (Iron)		18 × 18 × 1mm (Iron)	25 × 25 × 1mm (Iron)	30 × 30 × 1mm (Iron)	45 × 45 × 1mm (Iron)
Setting distance	0~1.4mm	0~2.8mm	0~3.5mm	0~5.6mm	0~7mm	0~10.5mm
Power supply (Operating voltage)	24-250VAC					
Leakage current	Max.10mA					
Response frequency (*1)	20Hz					
Residual voltage	Max. 10V					
Affection by Temp.	Max. ± 10% for sensing distance at ambient temperature 20℃					
Control output	Max. 200mA					
Insulation resistance	Min. 50MΩ (at 500VDC megger)					
Dielectric strength	1500VAC 50/60Hz for 1minute					
Vibration	1mm amplitude at frequency of 10 to 55Hz(for 1 min.) in each of X, Y, Z directions for 2 hours					
Shock	500m/s <sup>2</sup> (approx. 50G) X, Y, Z directions for 3 times					
Indicator	Operation indicator(red LED)					
Ambient temperature	-25~+70℃ (No icing)					
Storage temperature	-30~+80℃ (No icing)					
Ambient humidity	35~95%RH (No condensation)					
Protection circuit	Surge protection current					
Material	Case/Nut: Nickel plated Brass, Washer: Nickel plated Iron, Sensing surface: PBT, Standard cable(Gray): Polyvinyl chloride(PVC), Oil resistant cable(Black): Oil resistant Polyvinyl chloride(PVC)					
Cable	φ 3.8, 2P, 300mm, M12 connector		φ 4.8, 2P, 300mm, M12 connector			
Protection	IP67					

(\*1): The response frequency is the average value. The standard sensing target is used and the width is set as 2 times of the standard sensing target, 1/2 of the sensing distance for the distance.

Appearance and Dimension

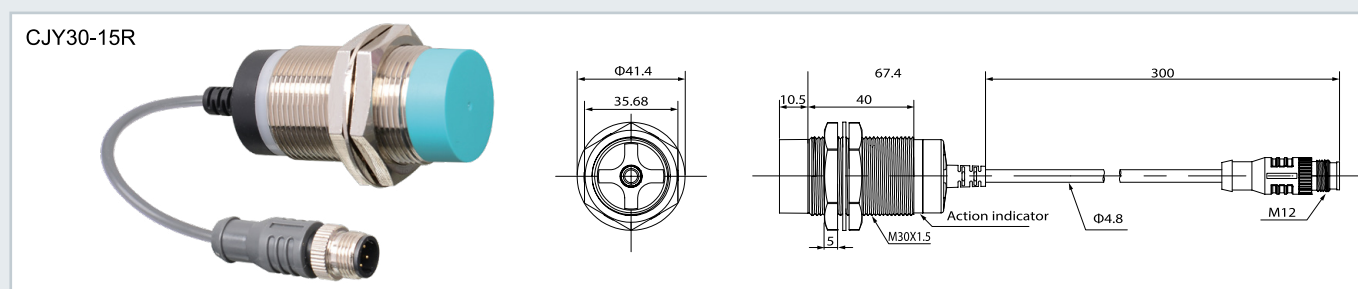
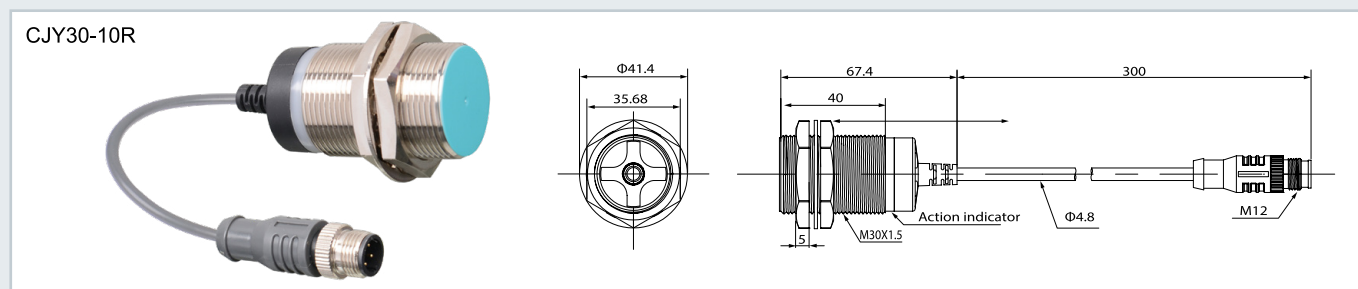
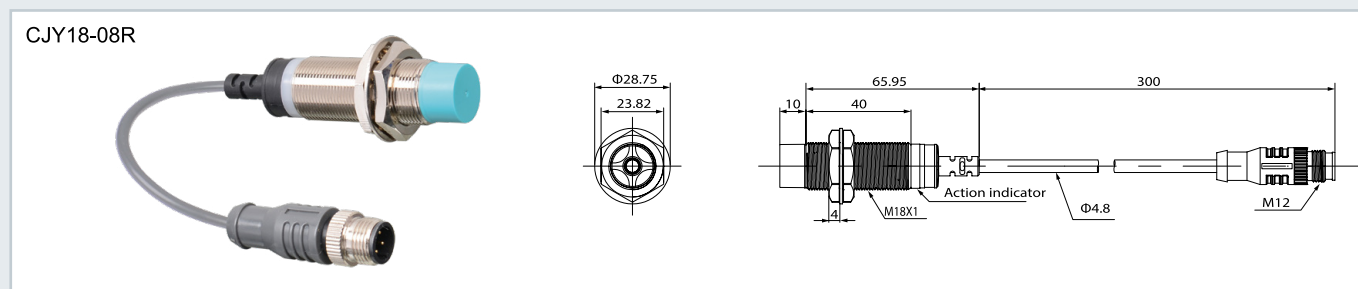
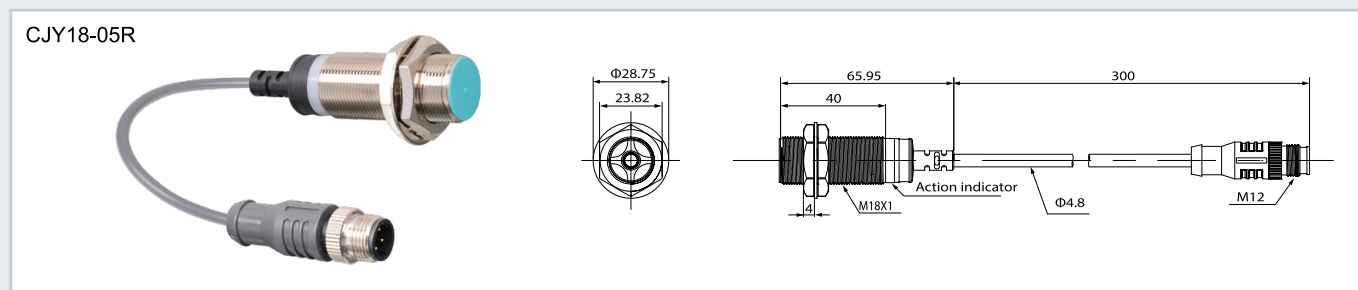
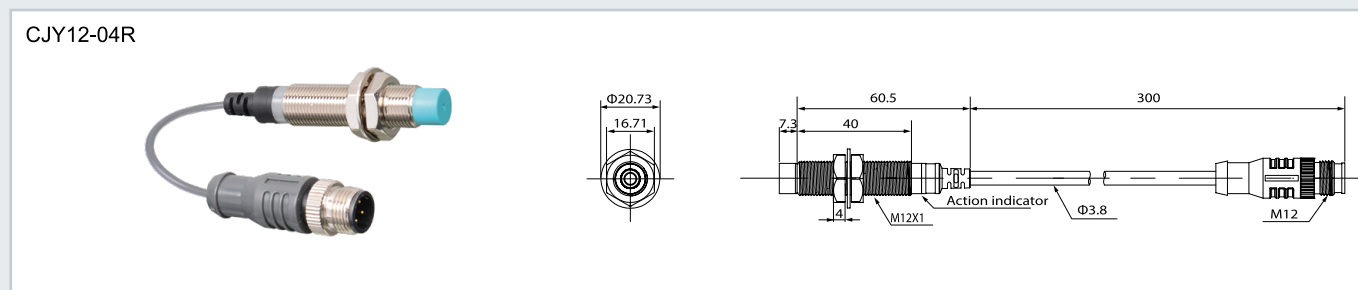
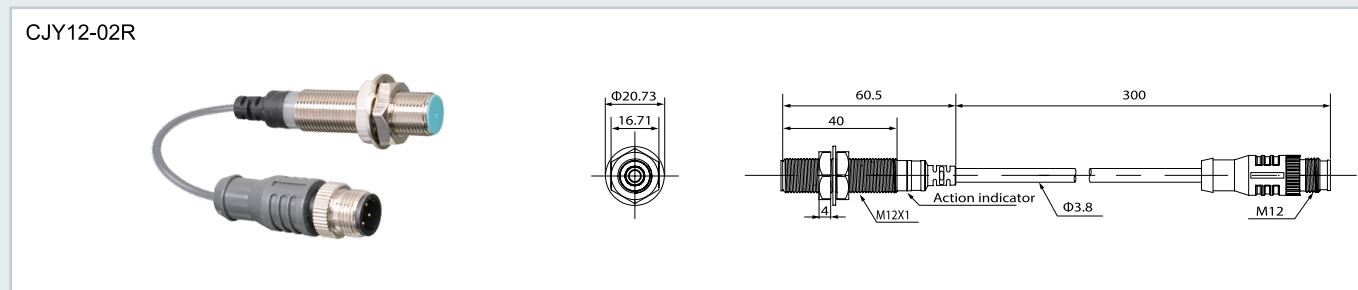

Appearance and Dimension

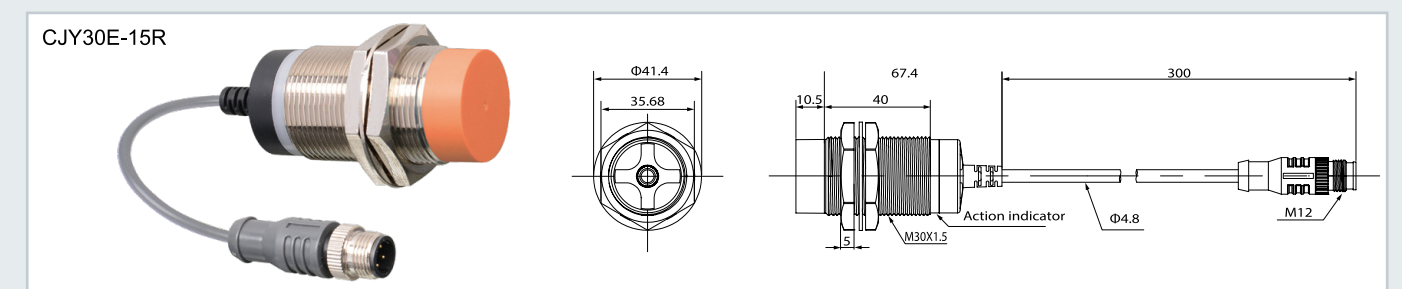
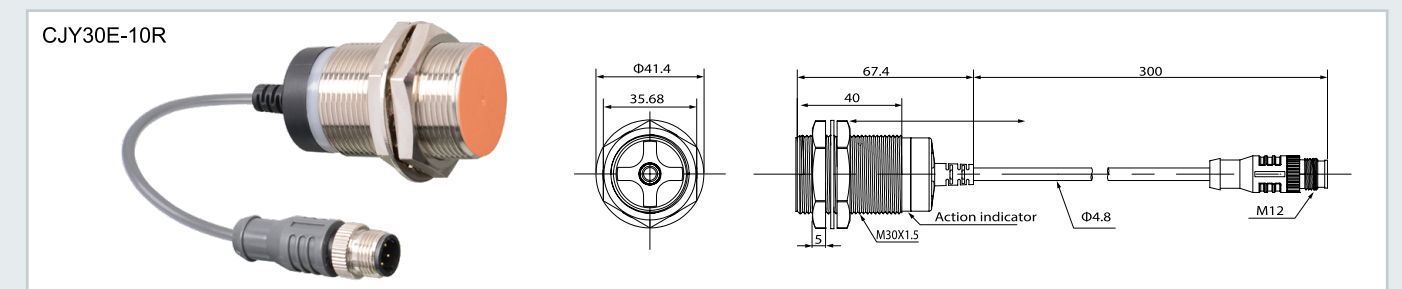
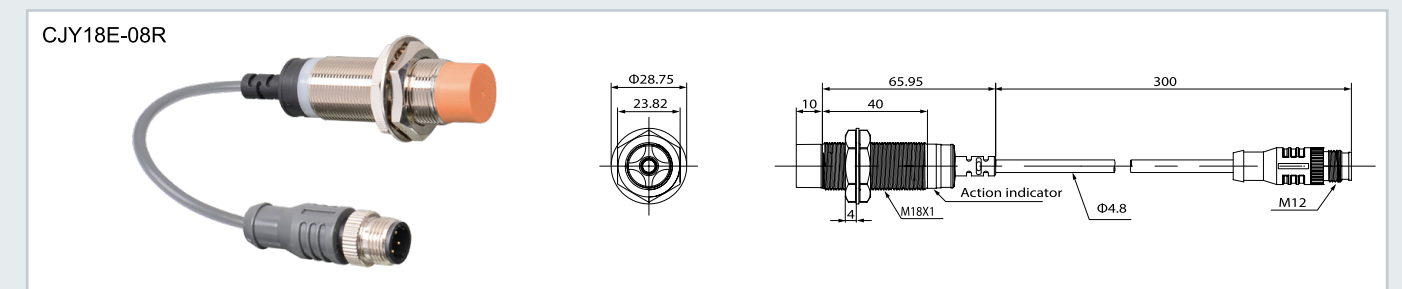
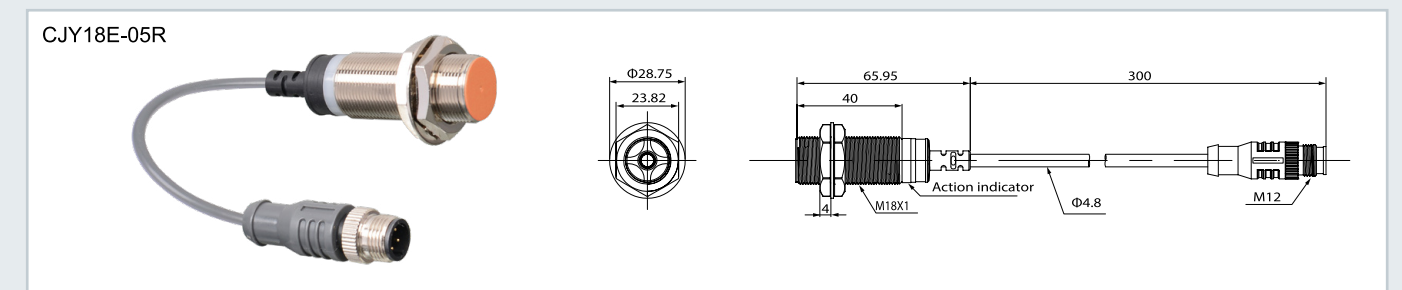
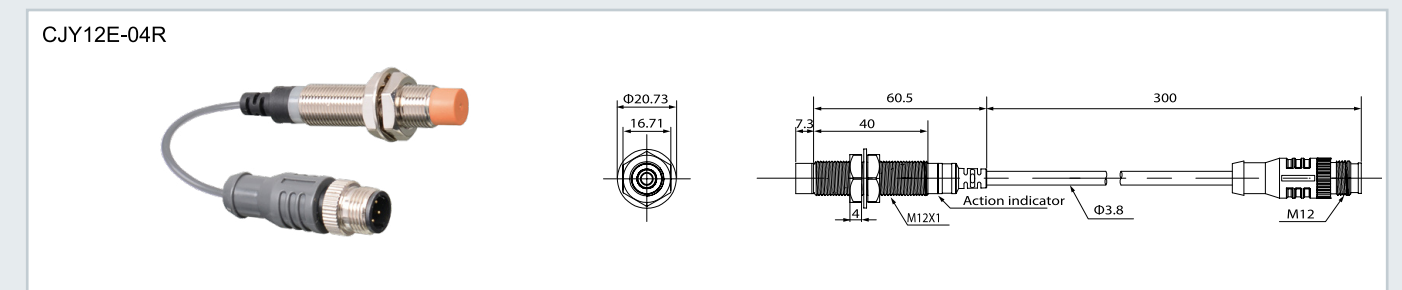
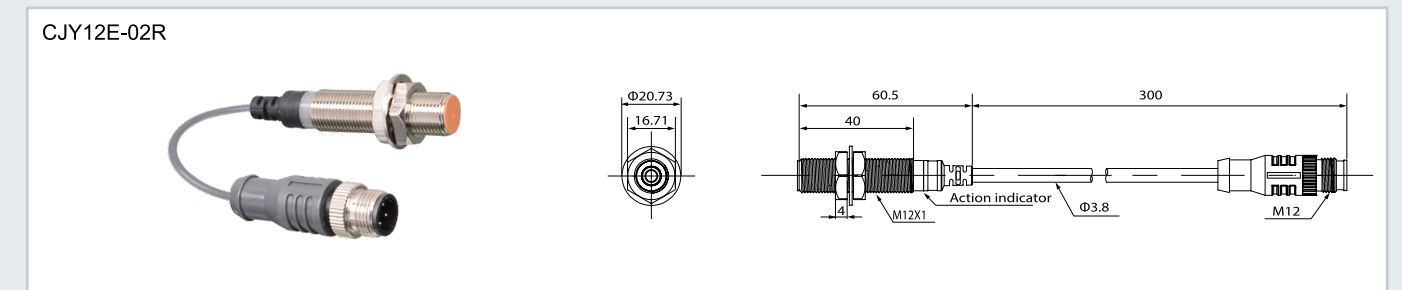





Control Output Diagram

DC 2-wire type

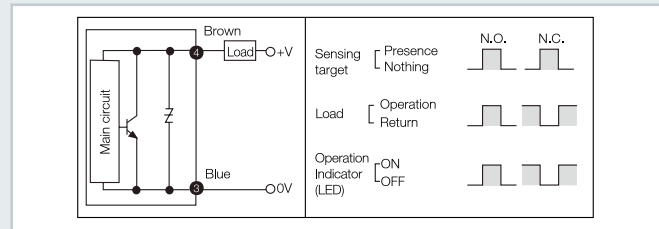

Wiring Diagram

DC 2-wire type (Standard type)

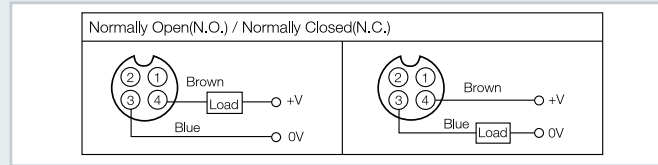

※ Pin ①, ② are not used terminals.  
 ※ When using DC 3-wire type of connector cable, black (12-24VDC) and blue(0V) cables can be used.

DC 3-wire type

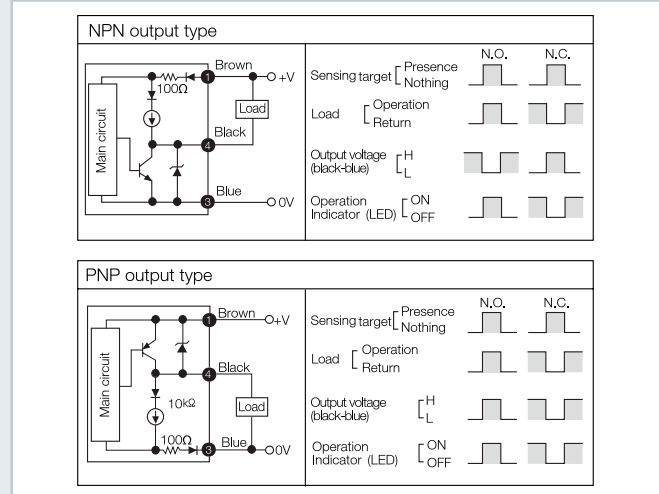

DC 2-wire type (IEC standard type)

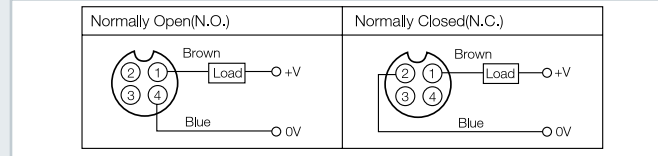

※ ②, ③ of N.O. type and ③, ④ of N.C. type are not used terminals.  
 ※ Please use the IEC specifications of the plug.

DC 3-wire type

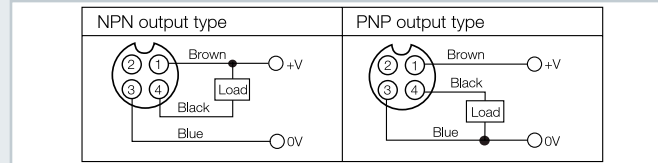

※ Please fasten the cleat of connector not to show the thread. (0.39 to 0.49N.m)  
 ※ Please fasten the vibration part with Teflon tape.

AC 2-wire type

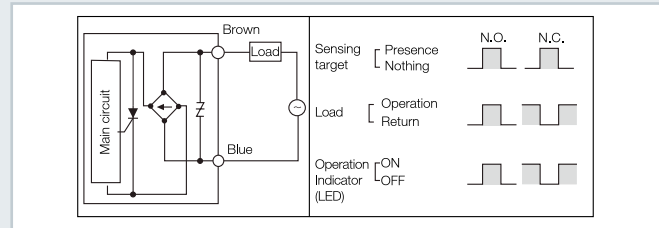

AC 2-wire type

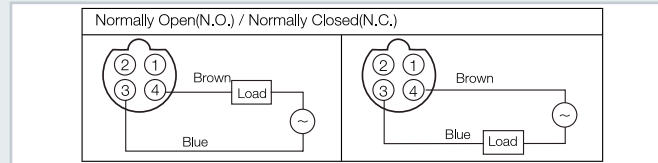

※ In case of AC switching type, ② and ③, ① and ④ are connected to each other inside.

Proper Usage

Mutual-interference

When several proximity sensors are mounted close to one another a malfunction of the sensor may be caused due to mutual interference. Therefore, be sure to provide a minimum distance between the two sensors as below chart indicates.

Influence by surrounding metals

When sensors are mounted on metallic panel, you must prevent the sensors from being affected by any metallic object except target. Therefore, be sure to provide a minimum distance as below chart indicates.

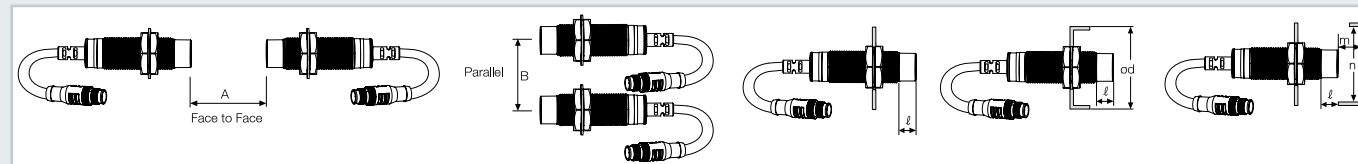

Model	CJY12-02R	CJY12-04R	CJY18-05R	CJY18-08R	CJY30-10R	CJY30-15R
Item	CJY12E-02R	CJY12E-04R	CJY18E-05R	CJY18E-08R	CJY30E-10R	CJY30E-15R
A	12	24	30	48	60	90
B	24	36	36	54	60	90
ℓ	0	11	0	14	0	15
φ d	12	36	18	54	30	90
m	6	12	15	24	30	45
n	18	36	27	54	45	90



Features

- Long sensing distance (1.5 to 2 times longer sensing distance guaranteed compared to existing models)
- Exclusively designed IC for improving anti-jamming capability
- Inside surge protection, reverse polarity protection, overcurrent protection
- Long use-life cycle and high reliability, easy install, economic price
- Red LED status indication, easy to confirm work situation
- Protection structure IP67(IEC standard)
- Replaceable for limit switches

Model Number Structure

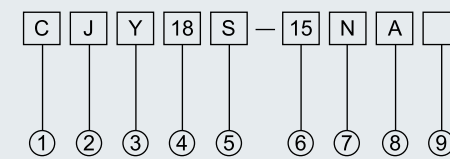

Item	Code	Description
① Company code	C	Company code
② Product name	J	Inductive proximity sensor
③ Shape of shell	Y	Cylinder-shaped
④ Dimension code	18	18=M18
⑤ Product type	S	Long-range type
⑥ Detection distance	15	15=15mm
⑦ Output mode	K	AC 2wires
	L	DC 2wires
	P	PNP 3wires
⑧ Output state	N	NPN 3wires
	A	NO
	B	NC
⑨ Connection	C	NO+NC
	Without	Without: Lead wire
	T	Plug-in
	R	Wiring leads Plug-in



Specifications

DC 3-wire type

Model	CJY08S-1.5NA CJY08S-1.5NB CJY08S-1.5PA CJY08S-1.5PB	CJY08S-03NA CJY08S-03NB CJY08S-03PA CJY08S-03PB	CJY12S-04NA CJY12S-04NB CJY12S-04PA CJY12S-04PB CJY12S-04PC	CJY12S-07NA CJY12S-07NB CJY12S-07PA CJY12S-07PB CJY12S-07PC	CJY18S-10NA CJY18S-10NB CJY18S-10PA CJY18S-10PB CJY18S-10PC	CJY18S-15NA CJY18S-15NB CJY18S-15PA CJY18S-15PB CJY18S-15PC	CJY30S-17NA CJY30S-17NB CJY30S-17PA CJY30S-17PB CJY30S-17PC	CJY30S-25NA CJY30S-25NB CJY30S-25PA CJY30S-25PB CJY30S-25PC
Sensing distance	1.5mm	3mm	4mm	7mm	10mm	15mm	17mm	25mm
Hysteresis	Max. 10% of sensing distance							
Standard sensing target	8 × 8 × 1mm (Iron)	8 × 8 × 1mm (Iron)	12 × 12 × 1mm (Iron)	25 × 25 × 1mm (Iron)	20 × 20 × 1mm (Iron)	40 × 40 × 1mm (Iron)	45 × 45 × 1mm (Iron)	75 × 75 × 1mm (Iron)
Setting distance	0~1.8mm	0~3.5mm	0~3.5mm	0~6.5mm	0~8.5mm	0~13.5mm	0~18.5mm	0~28.5mm
Power supply (Operating voltage)	12-24VDC (10-30VDC)							
Leakage current	Max. 10mA							
Response frequency (*1)	450Hz	400Hz	400Hz	300Hz	300Hz	200Hz	100Hz	100Hz
Residual voltage (*2)	Max. 1V							
Affection by Temp.	Max. ± 10% for sensing distance at ambient temperature 20 °C							
Control output	Max. 200mA							
Insulation resistance	Min. 50MΩ (at 500VDC megger)							
Dielectric strength	1500VAC 50/60Hz for 1minute							
Vibration	1mm amplitude at frequency of 10 to 55Hz(for 1 min.) in each of X, Y, Z directions for 2 hours							
Shock	500m/s <sup>2</sup> (approx. 50G) X, Y, Z directions for 3 times							
Indicator	Operation indicator(red LED)							
Ambient temperature	-25~+70 °C (No icing)							
Storage temperature	-30~+80 °C (No icing)							
Ambient humidity	35~95%RH (No condensation)							
Protection circuit	Surge protection circuit, Reverse polarity protection circuit, Overcurrent protection circuit							
Material	Case/Nut: Nickel plated Brass, Washer: Nickel plated Iron, Sensing surface: PBT, Standard cable(Gray): Polyvinyl chloride(PVC), Oil resistant cable(Black): Oil resistant Polyvinyl chloride(PVC)							
Cable	φ 2.8, 3P, 2m		φ 3.8, 3P,4P 2m		φ 4.8, 3P,4P 2m			
	(AWG22, Core diameter: 0.1mm, Number of cores: 22, Insulator diameter: φ 1.25)		(AWG22, Core diameter: 0.1mm, Number of cores: 25, Insulator diameter: φ 1.25)		(AWG22, Core diameter: 0.1mm, Number of cores: 30, Insulator diameter: φ 1.25)			
Protection	IP67							

(\*1): The response frequency is the average value. The standard sensing target is used and the width is set as 2 times of the standard sensing target, 1/2 of the sensing distance for the distance.

Appearance and Dimension

CJY08S-1.5			
CJY08S-03			
CJY12S-04			
CJY12S-07			
CJY18S-10			
CJY18S-15			
CJY30S-17			
CJY30S-25			



Control Output Diagram

DC 3-wire type

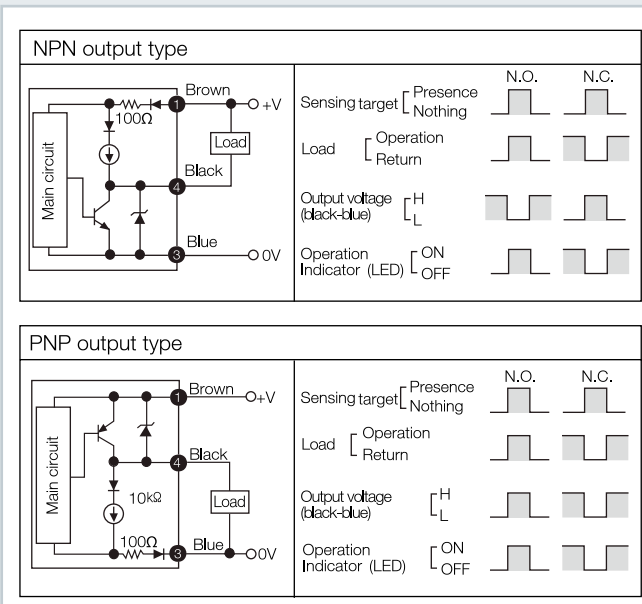

※ The number in a circle is pin no. of connector.

Wiring Diagram

DC 3-wire type (Standard type)

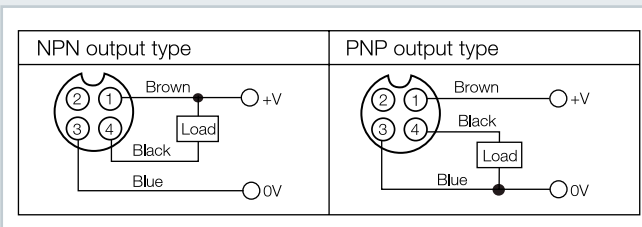

Proper Usage

Mutual-interference

When several proximity sensors are mounted close to one another a malfunction of the sensor may be caused due to mutual interference. Therefore, be sure to provide a minimum distance between the two sensors as below chart indicates.

Connections

DC 3-wire type

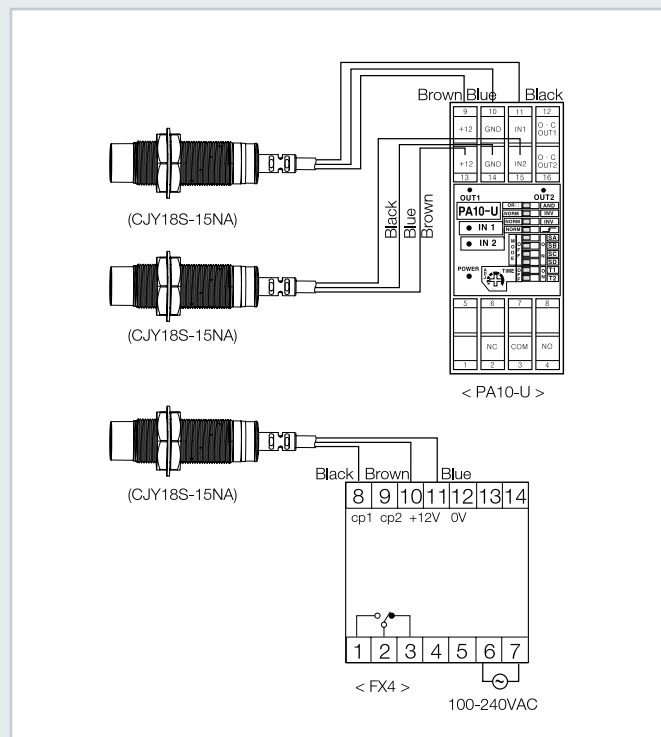

※ Please fasten the cleat of connector not to shown the thread. (0.39 to 0.49N.m)  
 ※ Please fasten the vibration part with Teflon tape.

Influence by surrounding metals

When sensors are mounted on metallic panel, you must prevent the sensors from being affected by any metallic object except target. Therefore, be sure to provide a minimum distance as below chart indicates.

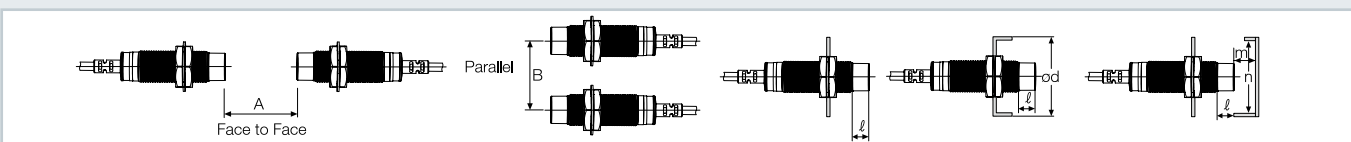

Item \ Model	CJY08S-1.5	CJY08S-03	CJY12S-04	CJY12S-07	CJY18S-10	CJY18S-15	CJY30S-17	CJY30S-25
A	9	12	24	48	42	84	90	150
B	16	24	24	36	36	54	60	90
ℓ	0	8	0	11	0	14	0	15
φ d	8	24	12	36	18	54	30	90
m	4.5	6	12	24	21	42	45	75
n	12	24	18	36	27	54	45	90



Features

- Long sensing distance (1.5 to 2 times longer sensing distance guaranteed compared to existing models)
- Exclusively designed IC for improved the noise resistance
- Inside surge protection, reverse polarity protection, overcurrent protection
- Long use-life cycle and high reliability, easy install, economic price
- Red LED status indication, easy to confirm work situation
- Protection structure IP65(IEC standard)
- Replaceable for limit switches

Model Number Structure

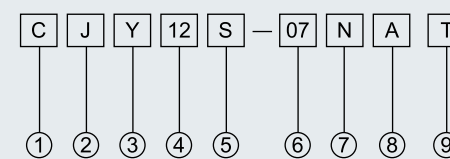

Item	Code	Description
① Company code	C	Company code
② Product name	J	Inductive proximity sensor
③ Shape of shell	Y	Cylinder-shaped
④ Dimension code	12	12=M12
⑤ Product type	S	Long-range type
⑥ Detection distance	07	07=7mm
⑦ Output mode	K	AC 2wires
	L	DC 2wires
	P	PNP 3wires
⑧ Output state	N	NPN 3wires
	A	NO
	B	NC
⑨ Connection	C	NO+NC
	Without	Without: Lead wire
	T	Plug-in
	R	Wiring leads Plug-in



Specifications

DC 3-wire type

Model	CJY12S-04NAT CJY12S-04NBT CJY12S-04NCT CJY12S-04PAT CJY12S-04PBT CJY12S-04PCT	CJY12S-07NAT CJY12S-07NBT CJY12S-07NCT CJY12S-07PAT CJY12S-07PBT CJY12S-07PCT	CJY18S-10NAT CJY18S-10NBT CJY18S-10NCT CJY18S-10PAT CJY18S-10PBT CJY18S-10PCT	CJY18S-15NAT CJY18S-15NBT CJY18S-15NCT CJY18S-15PAT CJY18S-15PBT CJY18S-15PCT	CJY30S-17NAT CJY30S-17NBT CJY30S-17NCT CJY30S-17PAT CJY30S-17PBT CJY30S-17PCT	CJY30S-25NAT CJY30S-25NBT CJY30S-25NCT CJY30S-25PAT CJY30S-25PBT CJY30S-25PCT
Sensing distance	4mm	7mm	10mm	15mm	17mm	25mm
Hysteresis	Max. 10% of sensing distance					
Standard sensing target	12 × 12 × 1mm (Iron)	25 × 25 × 1mm (Iron)	20 × 20 × 1mm (Iron)	40 × 40 × 1mm (Iron)	45 × 45 × 1mm (Iron)	75 × 75 × 1mm (Iron)
Setting distance	0~2.8mm	0~5.6mm	0~4.9mm	0~9.8mm	0~10.5mm	0~17.5mm
Power supply (Operating voltage)	12-24VDC (10-30VDC)					
Leakage current	Max. 10mA					
Response frequency (※1)	400Hz	300Hz	300Hz	200Hz	100Hz	100Hz
Residual voltage	Max. 1V					
Affection by Temp.	Max. ± 10% for sensing distance at ambient temperature 20°C					
Control output	Max. 200mA					
Insulation resistance	Min. 50MΩ (at 500VDC megger)					
Dielectric strength	1500VAC 50/60Hz for 1minute					
Vibration	1mm amplitude at frequency of 10 to 55Hz(for 1 min.) in each of X, Y, Z directions for 2 hours					
Shock	500m/s <sup>2</sup> (approx. 50G) X, Y, Z directions for 3 times					
Indicator	Operation indicator(red LED)					
Ambient temperature	-25~+70°C (No icing)					
Storage temperature	-30~+80°C (No icing)					
Ambient humidity	35~95%RH (No condensation)					
Protection circuit	Surge protection circuit, Reverse polarity protection circuit, Overcurrent protection circuit					
Material	Case/Nut: Nickel plated Brass, Washer: Nickel plated Iron, Sensing surface: PBT					
Protection	IP65					

(※1) The response frequency is the average value. The standard sensing target is used and the width is set as 2 times of the standard sensing target, 1/2 of the sensing distance for the distance.

Appearance and Dimension

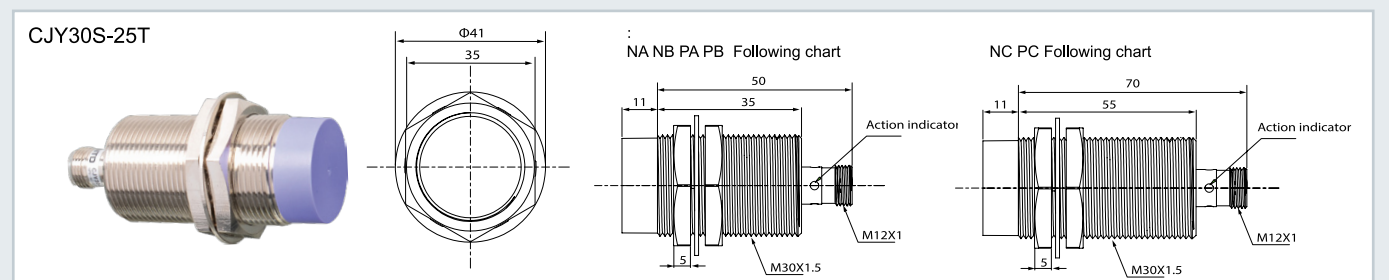
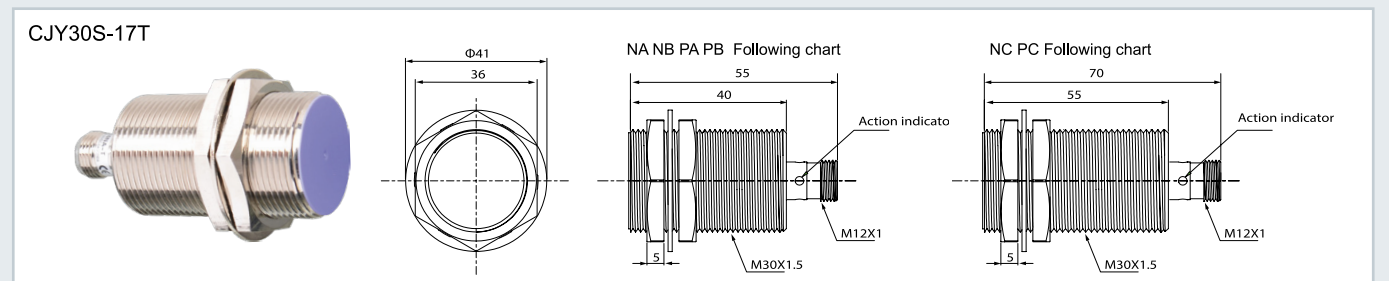
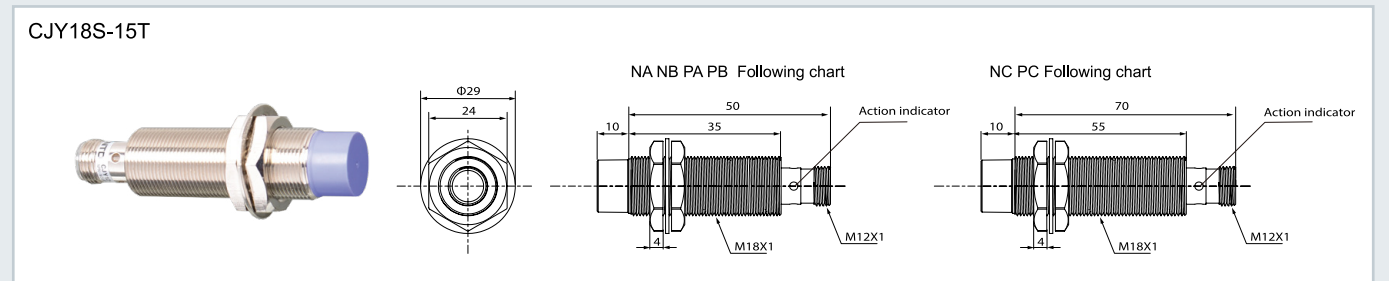
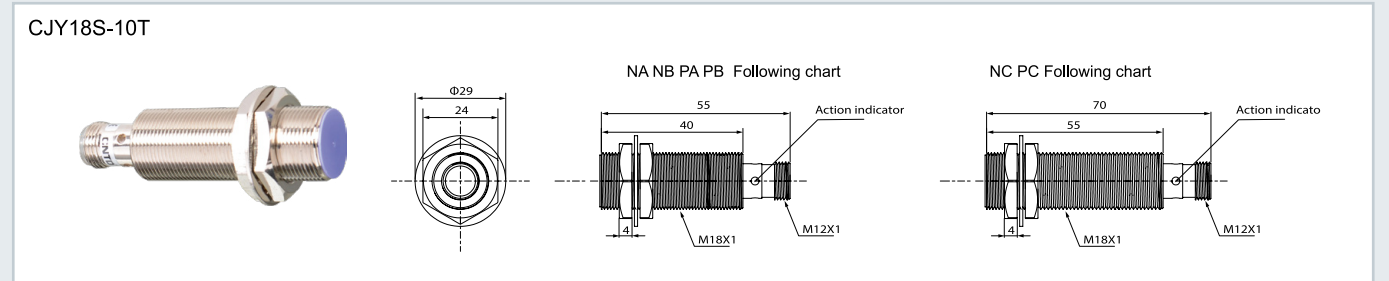
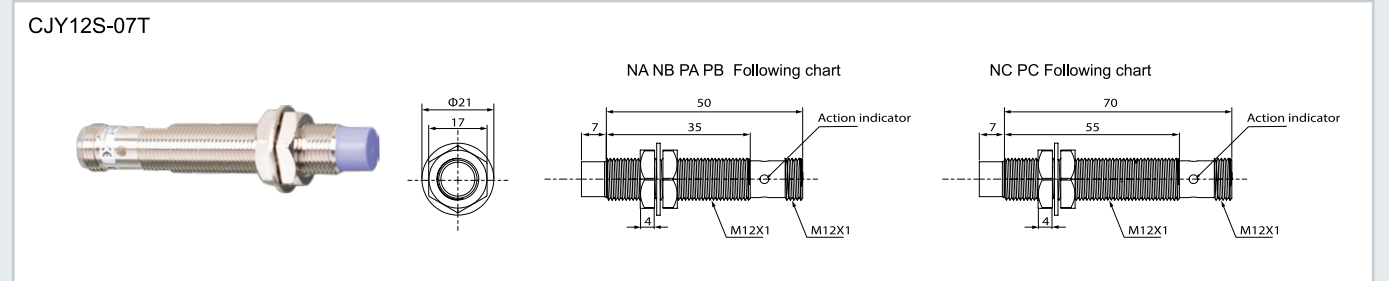
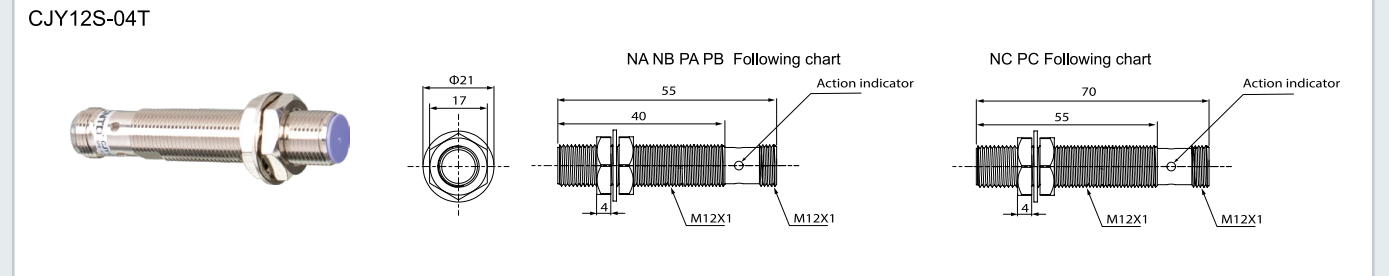





Control Output Diagram

DC 3-wire type

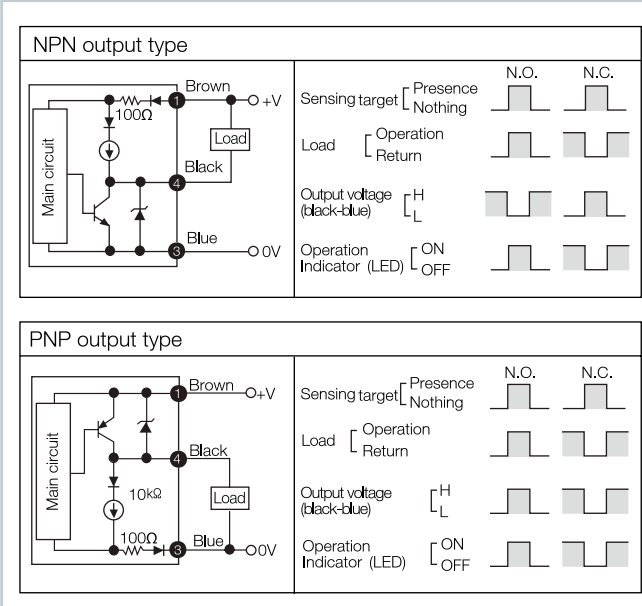

※ The number in a circle is pin no. of connector.

Proper Usage

Mutual-interference

When several proximity sensors are mounted close to one another a malfunction of the sensor may be caused due to mutual interference. Therefore, be sure to provide a minimum distance between the two sensors as below chart indicates.

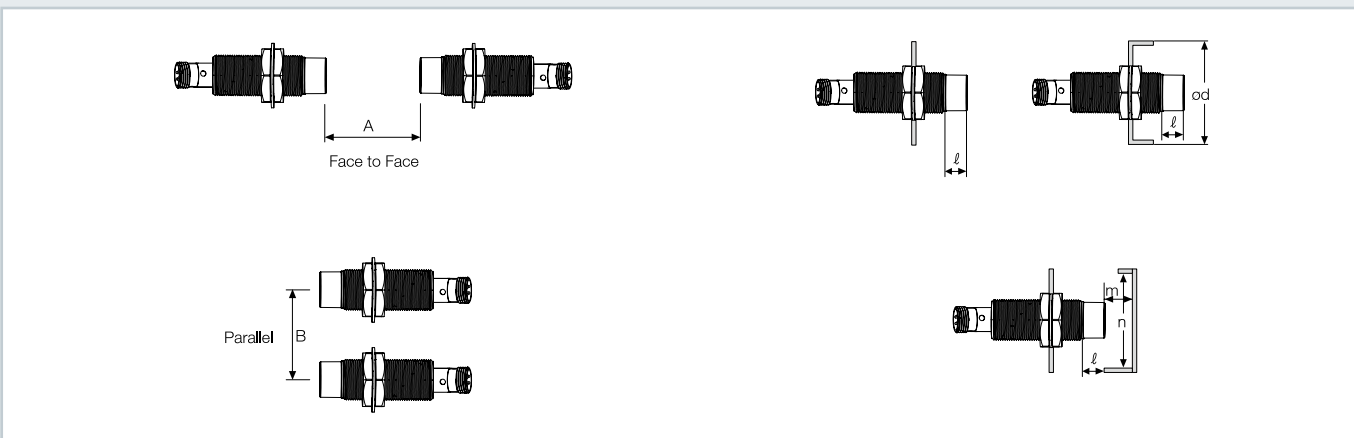

Model	CJY12S-04T	CJY12S-07T	CJY18S-10T	CJY18S-15T	CJY30S-17T	CJY30S-25T
A	24	48	42	84	90	150
B	24	36	36	54	60	90
ℓ	0	11	0	14	0	15
φ d	12	36	18	54	30	90
m	12	24	21	42	45	75
n	18	36	27	54	45	90

Wiring Diagram

DC 3-wire type (Standard type)

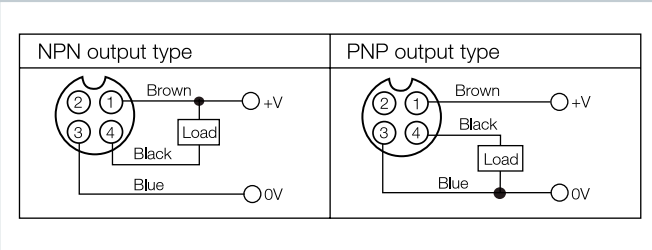

※ Please fasten the cleat of connector not to shown the thread. (0.39 to 0.49N.m)

※ Please fasten the vibration part with Teflon tape.

Influence by surrounding metals

When sensors are mounted on metallic panel, you must prevent the sensors from being affected by any metallic object except target. Therefore, be sure to provide a minimum distance as below chart indicates.



Features

- Long sensing distance (1.5 to 2 times longer sensing distance guaranteed compared to existing models)
- Exclusively designed IC for improving anti-jamming capability
- Inside surge protection, reverse polarity protection, overcurrent protection
- Long use-life cycle and high reliability, easy install, economic price
- Red LED status indication, easy to confirm work situation
- Protection structure IP67(IEC standard)
- Replaceable for limit switches

Model Number Structure

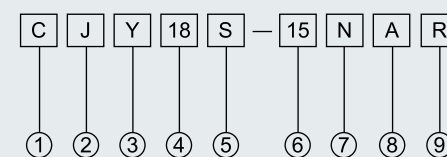

Item	Code	Description
① Company code	C	Company code
② Product name	J	Inductive proximity sensor
③ Shape of shell	Y	Cylinder-shaped
④ Dimension code	18	18=M18
⑤ Product type	S	Long-range type
⑥ Detection distance	15	15=15mm
⑦ Output mode	K	AC 2wires
	L	DC 2wires
	P	PNP 3wires
⑧ Output state	N	NPN 3wires
	A	NO
	B	NC
⑨ Connection	C	NO+NC
	Without	Without: Lead wire
	T	Plug-in
	R	Wiring leads Plug-in



Specifications

DC 3-wire type

Model	CJY12S-04NAR CJY12S-04NBR CJY12S-04NCR CJY12S-04PAR CJY12S-04PBR CJY12S-04PCR	CJY12S-07NAR CJY12S-07NBR CJY12S-07NCR CJY12S-07PAR CJY12S-07PBR CJY12S-07PCR	CJY18S-10NAR CJY18S-10NBR CJY18S-10NCR CJY18S-10PAR CJY18S-10PBR CJY18S-10PCR	CJY18S-15NAR CJY18S-15NBR CJY18S-15NCR CJY18S-15PAR CJY18S-15PBR CJY18S-15PCR	CJY30S-17NAR CJY30S-17NBR CJY30S-17NCR CJY30S-17PAR CJY30S-17PBR CJY30S-17PCR	CJY30S-25NAR CJY30S-25NBR CJY30S-25NCR CJY30S-25PAR CJY30S-25PBR CJY30S-25PCR
Sensing distance	4mm	7mm	10mm	15mm	17mm	25mm
Hysteresis	Max. 10% of sensing distance					
Standard sensing target	12 × 12 × 1mm (Iron)	25 × 25 × 1mm (Iron)	20 × 20 × 1mm (Iron)	40 × 40 × 1mm (Iron)	45 × 45 × 1mm (Iron)	75 × 75 × 1mm (Iron)
Setting distance	0~2.8mm	0~5.6mm	0~4.9mm	0~9.8mm	0~10.5mm	0~17.5mm
Power supply (Operating voltage)	12-24VDC (10-30VDC)					
Leakage current	Max. 10mA					
Response frequency (※1)	400Hz	300Hz	300Hz	200Hz	100Hz	100Hz
Residual voltage	Max. 1V					
Affection by Temp.	Max. ± 10% for sensing distance at ambient temperature 20℃					
Control output	Max. 200mA					
Insulation resistance	Min. 50MΩ (at 500VDC megger)					
Dielectric strength	1500VAC 50/60Hz for 1minute					
Vibration	1mm amplitude at frequency of 10 to 55Hz(for 1 min.) in each of X, Y, Z directions for 2 hours					
Shock	500m/s <sup>2</sup> (approx. 50G) X, Y, Z directions for 3 times					
Indicator	Operation indicator(red LED)					
Ambient temperature	-25~+70℃ (No icing)					
Storage temperature	-30~+80℃ (No icing)					
Ambient humidity	35~95%RH (No condensation)					
Protection circuit	Surge protection circuit, Reverse polarity protection circuit, Overcurrent protection circuit					
Material	Case/Nut: Nickel plated Brass, Washer: Nickel plated Iron, Sensing surface: PBT					
Cable	φ 3.8, 3P,4P 300mm, M12 connector		φ 4.8, 3P,4P 300mm, M12 connector			
Protection	IP67					

(※1) The response frequency is the average value. The standard sensing target is used and the width is set as 2 times of the standard sensing target, 1/2 of the sensing distance for the distance.

Appearance and Dimension

**CJY12S-04R**

**CJY12S-07R**

**CJY18S-10R**

**CJY18S-15R**

**CJY30S-17R**

**CJY30S-25R**





Control Output Diagram

DC 3-wire type

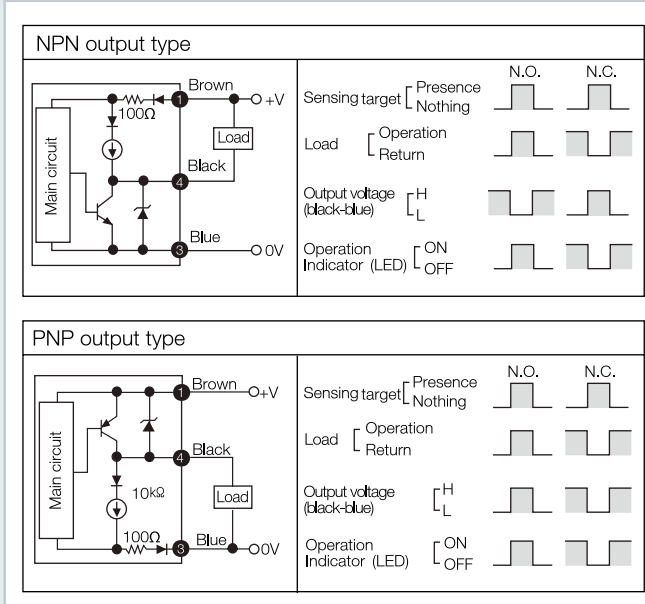

※ The number in a circle is pin no. of connector.

Wiring Diagram

DC 3-wire type (Standard type)

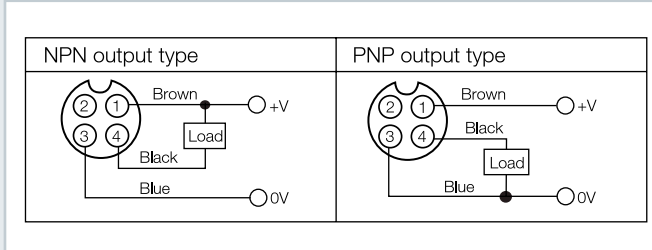

※ Please fasten the cleat of connector not to shown the thread. (0.39 to 0.49N.m)

※ Please fasten the vibration part with Teflon tape.

Proper Usage

Mutual-interference

When several proximity sensors are mounted close to one another a malfunction of the sensor may be caused due to mutual interference. Therefore, be sure to provide a minimum distance between the two sensors as below chart indicates.

Influence by surrounding metals

When sensors are mounted on metallic panel, you must prevent the sensors from being affected by any metallic object except target. Therefore, be sure to provide a minimum distance as below chart indicates.

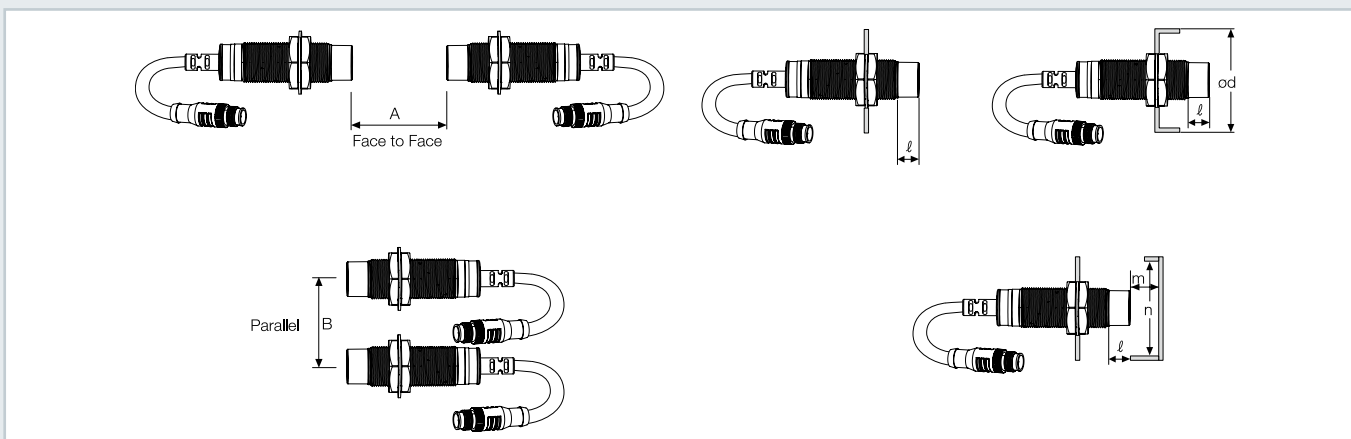

Model	CJY12S-04R	CJY12S-07R	CJY18S-10R	CJY18S-15R	CJY30S-17R	CJY30S-25R
A	24	48	42	84	90	150
B	24	36	36	54	60	90
l	0	11	0	14	0	15
φ d	12	36	18	54	30	90
m	12	24	21	42	45	75
n	18	36	27	54	45	90

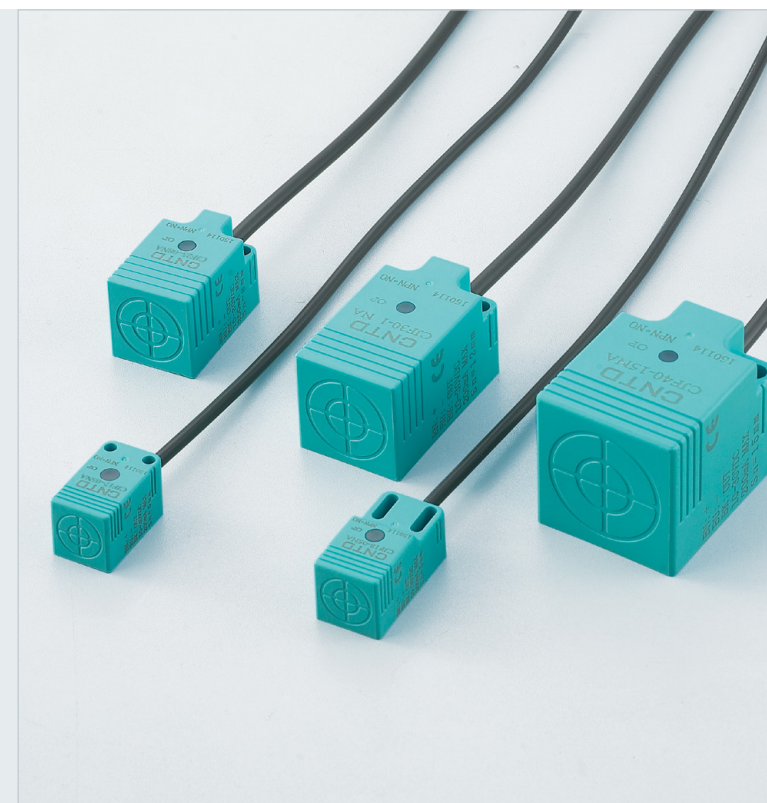

Features

- Orange mark for standard type
- Light green mark for high-end type
- Inside surge protection, reverse polarity protection, overcurrent protection
- Long use-life cycle and high reliability, easy install, economic price
- Red LED status indication, easy to confirm work situation
- Protection structure IP67(IEC standard)
- Replaceable for limit switches

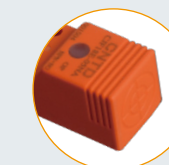

Orange

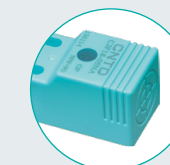

Light green

Model Number Structure

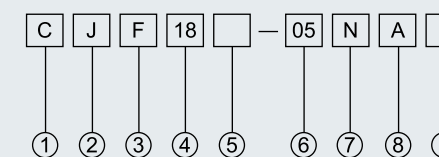

Item	Code	Description
① Company code	C	Company code
② Product name	J	Inductive proximity sensor
③ Shape of shell	F	Square
④ Dimension code	18	18=8 Square18
⑤ Product type	Without	Without =High-end type (Light green shell)
	E	E =Standard type (Orange shell)
⑥ Detection distance	05	05=5mm
⑦ Output mode	K	AC 2wires
	L	DC 2wires
	P	PNP 3wires
	N	NPN 3wires
⑧ Output state	A	NO
	B	NC
	C	NO+NC
⑨ Connection	Without	Without: Lead wire
	T	Plug-in
	R	Wiring leads Plug-in



Specifications

DC 3-wire type

Model	High-end type	CJF17-05NA CJF17-05NB CJF17-05PA CJF17-05PB	CJF18-05NA CJF18-05NB CJF18-05PA CJF18-05PB	CJF25-08NA CJF25-08NB CJF25-08PA CJF25-08PB	CJF30-12NA CJF30-12NB CJF30-12PA CJF30-12PB	CJF40-15NA CJF40-15NB CJF40-15PA CJF40-15PB
	Standard type	CJF17E-05NA CJF17E-05NB CJF17E-05PA CJF17E-05PB	CJF18E-05NA CJF18E-05NB CJF18E-05PA CJF18E-05PB	CJF25E-08NA CJF25E-08NB CJF25E-08PA CJF25E-08PB	CJF30E-12NA CJF30E-12NB CJF30E-12PA CJF30E-12PB	CJF40E-15NA CJF40E-15NB CJF40E-15PA CJF40E-15PB
Sensing distance		5mm	5mm	8mm	12mm	15mm
Hysteresis	Max. 10% of sensing distance					
Standard sensing target		18 × 18 × 1mm (Iron)	25 × 25 × 1mm (Iron)	30 × 30 × 1mm (Iron)	40 × 40 × 1mm (Iron)	60 × 60 × 1mm (Iron)
Setting distance		0~3.5mm	0~3.5mm	0~5.5mm	0~7.5mm	0~12.5mm
Power supply (Operating voltage)	12-24VDC (10-30VDC)					
Leakage current	Max.10mA					
Response frequency (*1)		500Hz	500Hz	350Hz	250Hz	100Hz
Residual voltage	Max. 1.0V					
Affection by Temp.	Max. ± 10% for sensing distance at ambient temperature 20℃					
Control output	Max. 200mA					
Insulation resistance	Min. 50MΩ (at 500VDC megger)					
Dielectric strength	1500VAC 50/60Hz for 1minute					
Vibration	1mm amplitude at frequency of 10 to 55Hz(for 1 min.) in each of X, Y, Z directions for 2 hours					
Shock	500m/s <sup>2</sup> (approx. 50G) X, Y, Z directions for 3 times					
Indicator	Operation indicator(red LED)					
Ambient temperature	-25~+70℃ (No icing)					
Storage temperature	-30~+80℃ (No icing)					
Ambient humidity	35~95%RH (No condensation)					
Protection circuit	Surge protection circuit, Overcurrent protection circuit, Reverse polarity protection circuit					
Cable	High-end type	φ 3.8, 3P, 2m		φ 4.8, 3P, 2m		
	Standard type	AWG22, Core diameter: 0.1mm, Number of cores: 25, Insulator diameter: φ 1.25		AWG22, Core diameter: 0.1mm, Number of cores: 30, Insulator diameter: φ 1.25		
Material	Case: ABS, Standard cable(Dark Grey): Polyvinyl chloride(PVC)					
Protection	IP67					

(\*1): The response frequency is the average value. The standard sensing target is used and the width is set as 2 times of the standard sensing target, 1/2 of the sensing distance for the distance.

Specifications

DC 2-wire type

Model	High-end type	CJF17-05LA CJF17-05LB	CJF18-05LA CJF18-05LB	CJF25-08LA CJF25-08LB	CJF30-12LA CJF30-12LB	CJF40-15LA CJF40-15LB
	Standard type	CJF17E-05LA	CJF18E-05LA	CJF25E-08LA	CJF30E-12LA	CJF40E-15LA
Sensing distance		5mm	5mm	8mm	12mm	15mm
Hysteresis	Max. 10% of sensing distance					
Standard sensing target		18 × 18 × 1mm (Iron)	25 × 25 × 1mm (Iron)	30 × 30 × 1mm (Iron)	40 × 40 × 1mm (Iron)	60 × 60 × 1mm (Iron)
Setting distance		0~3.5mm	0~3.5mm	0~5.5mm	0~7.5mm	0~12.5mm
Power supply (Operating voltage)	12-24VDC (10-30VDC)					
Leakage current	Max.0.6mA					
Response frequency (*1)		500Hz	500Hz	350Hz	250Hz	100Hz
Residual voltage	Max. 3.5V					
Affection by Temp.	Max. ± 10% for sensing distance at ambient temperature 20℃					
Control output	Max. 200mA					
Insulation resistance	Min. 50MΩ (at 500VDC megger)					
Dielectric strength	1500VAC 50/60Hz for 1minute					
Vibration	1mm amplitude at frequency of 10 to 55Hz(for 1 min.) in each of X, Y, Z directions for 2 hours					
Shock	500m/s <sup>2</sup> (approx. 50G) X, Y, Z directions for 3 times					
Indicator	Operation indicator(red LED)					
Ambient temperature	-25~+70℃ (No icing)					
Storage temperature	-30~+80℃ (No icing)					
Ambient humidity	35~95%RH (No condensation)					
Protection circuit	Surge protection circuit, Reverse polarity protection circuit, Overcurrent protection circuit					
Cable	High-end type	φ 3.8, 2P, 2m		φ 4.8, 2P, 2m		
	Standard type	AWG22, Core diameter: 0.1mm, Number of cores: 25, Insulator diameter: φ 1.25		AWG22, Core diameter: 0.1mm, Number of cores: 30, Insulator diameter: φ 1.25		
Material	Case: ABS, Standard cable(Dark Grey): Polyvinyl chloride(PVC)					
Protection	IP67					

(\*1): The response frequency is the average value. The standard sensing target is used and the width is set as 2 times of the standard sensing target, 1/2 of the sensing distance for the distance.





Specifications

AC 2-wire type

Model	High-end type	CJF25-08KA CJF25-08KB	CJF30-12KA CJF30-12KB	CJF40-15KA CJF40-15KB
	Standard type	CJF25E-08KA CJF25E-08KB	CJF30E-12KA CJF30E-12KB	CJF40E-15KA CJF40E-15KB
Sensing distance		8mm	12mm	15mm
Hysteresis	Max. 10% of sensing distance			
Standard sensing target		30 × 30 × 1mm (Iron)	40 × 40 × 1mm (Iron)	60 × 60 × 1mm (Iron)
Setting distance		0~5.5mm	0~7.5mm	0~12.5mm
Power supply (Operating voltage)	24-250VAC			
Leakage current	Max. 10mA			
Response frequency (※1)	20Hz			
Residual voltage	Max. 10V			
Affection by Temp.	Max. ± 10% for sensing distance at ambient temperature 20°C			
Control output	Max. 200mA			
Insulation resistance	Min. 50MΩ (at 500VDC megger)			
Dielectric strength	1500VAC 50/60Hz for 1minute			
Vibration	1mm amplitude at frequency of 10 to 55Hz(for 1 min.) in each of X, Y, Z directions for 2 hours			
Shock	500m/s <sup>2</sup> (approx. 50G) X, Y, Z directions for 3 times			
Indicator	Operation indicator(red LED)			
Ambient temperature	-25~+70°C (No icing)			
Storage temperature	-30~+80°C (No icing)			
Ambient humidity	35~95%RH (No condensation)			
Protection circuit	Surge protection circuit			
Cable	High-end type	(AWG22, Core diameter: 0.1mm, Number of cores: 30, Insulator diameter: φ 1.25)		
	Standard type	(AWG22, Core diameter: 0.1mm, Number of cores: 30, Insulator diameter: φ 1.25)		
Material	Case: ABS, Standard cable(Dark Grey): Polyvinyl chloride(PVC)			
Protection	IP67			

(※1): The response frequency is the average value. The standard sensing target is used and the width is set as 2 times of the standard sensing target, 1/2 of the sensing distance for the distance.

Appearance and Dimension

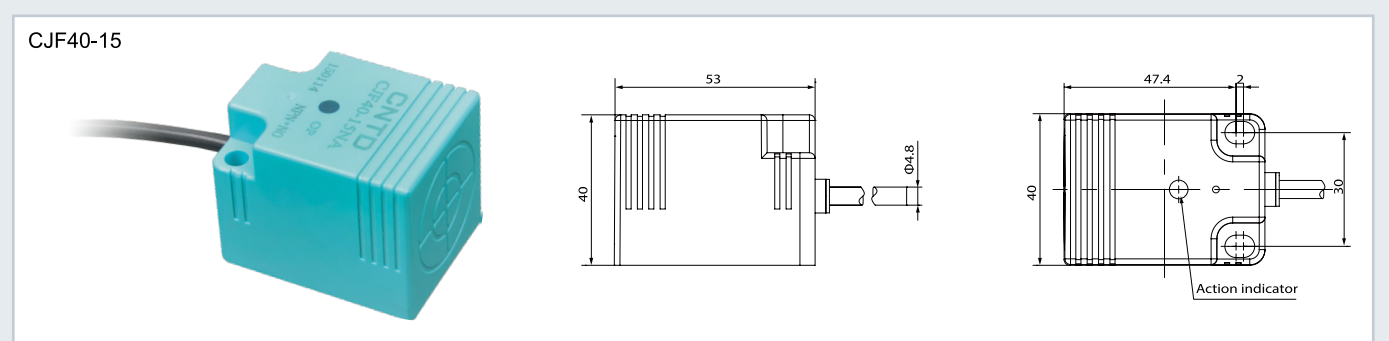
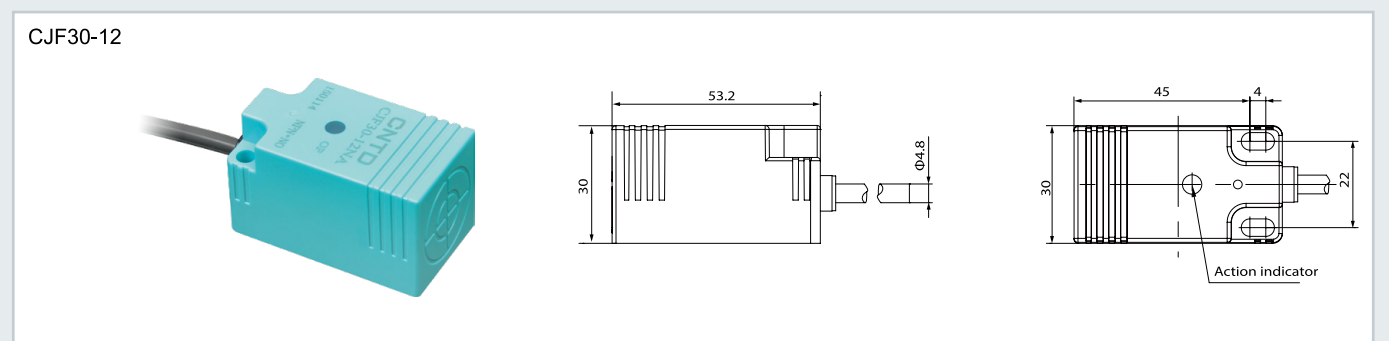
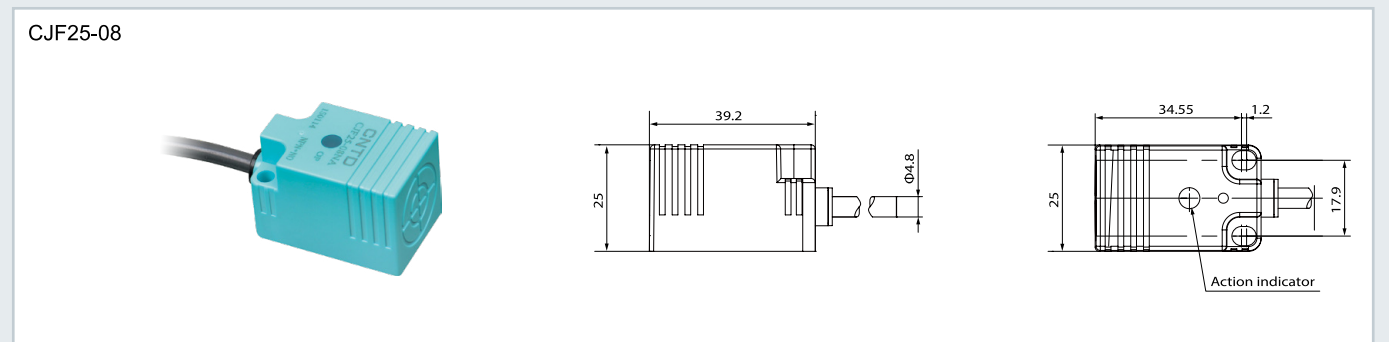
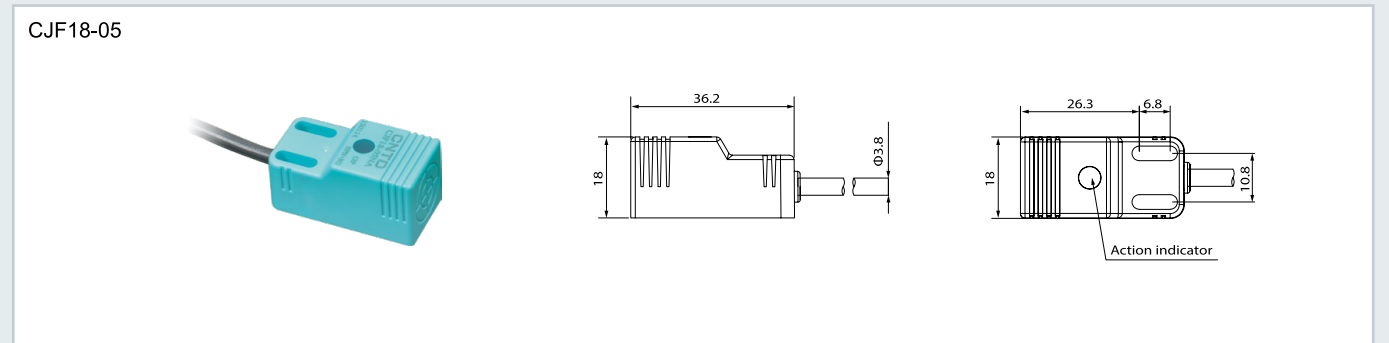
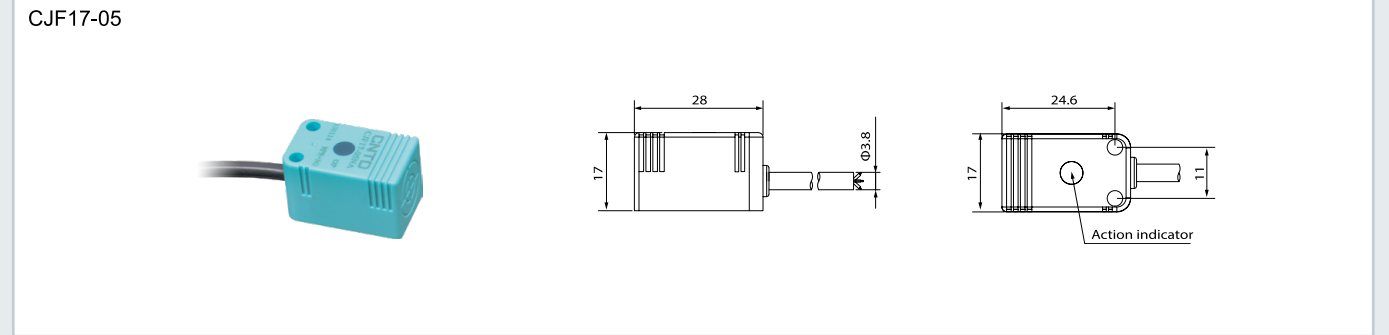

Appearance and Dimension

**CJF17E-05**

**CJF18E-05**

**CJF25E-08**

**CJF30E-12**

**CJF40E-15**

Control Output Diagram

DC 2-wire type

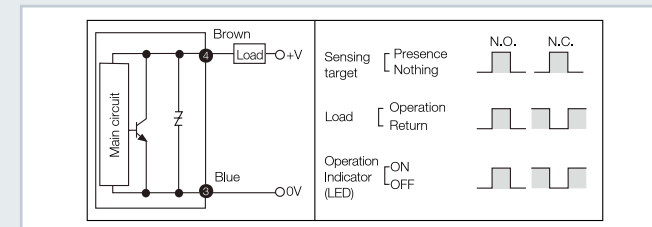

AC 2-wire type

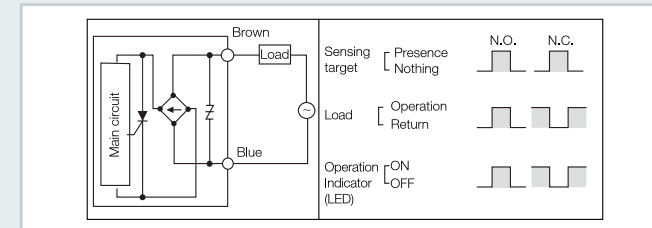

DC 3-wire type

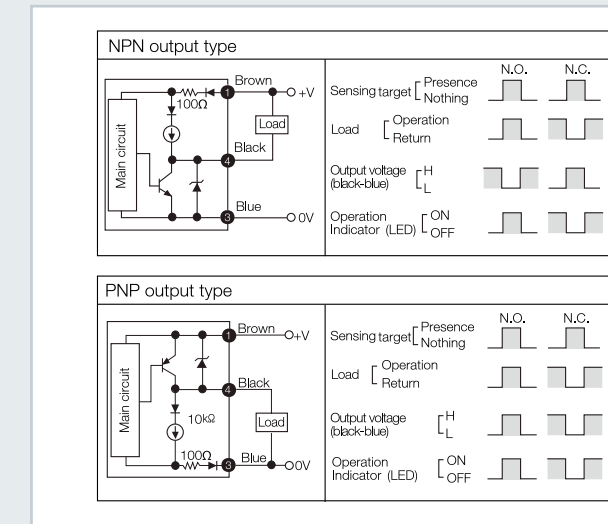

Connections

DC 2-wire type

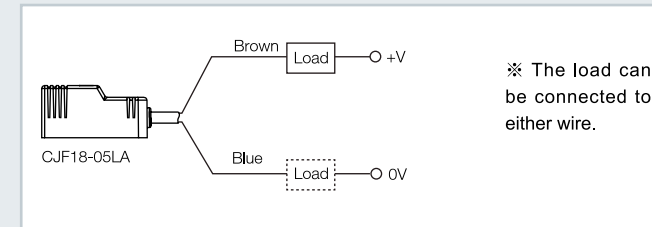

AC 2-wire type

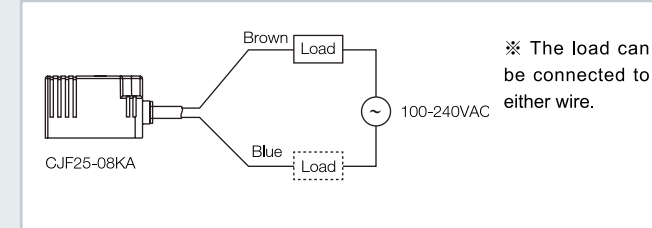

DC 3-wire type

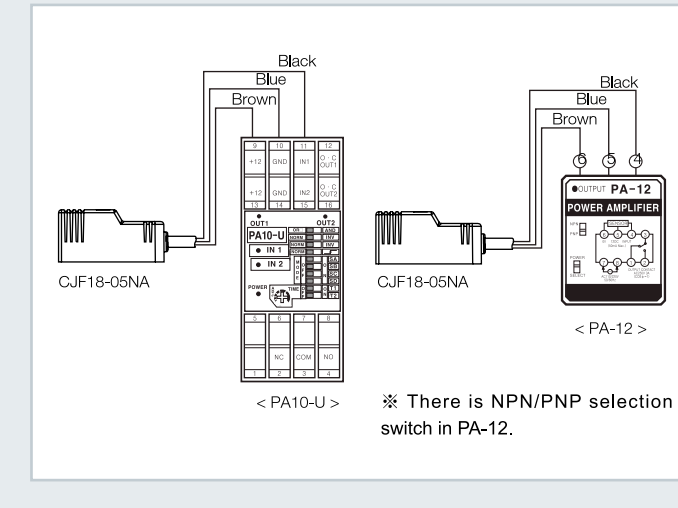

Proper Usage

Mutual-interference

When several proximity sensors are mounted close to one another a malfunction of the may be caused due to mutual interference. Therefore, be sure to provide a minimum distance between the two sensors as below chart indicates.

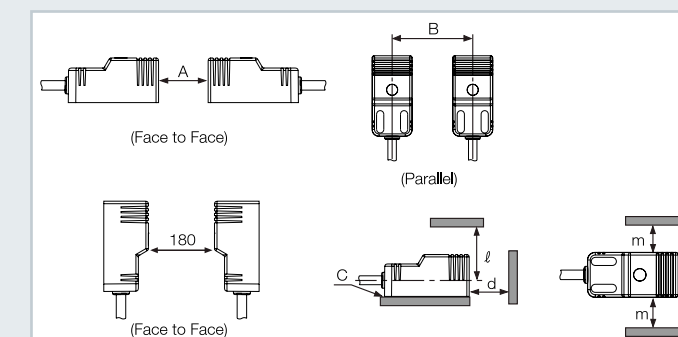

Item	Model	CJF17-05	CJF18-05	CJF25-08	CJF30-12	CJF40-15
		CJF17E-05	CJF18E-05	CJF25E-08	CJF30E-12	CJF40E-15
A		30	48	30	60	120
B		36	40	40	50	70
C		5	5	5	5	5
φ d		15	24	15	30	60
l		24	33	25	30	45
m		18	20	20	25	35





**Features**

- Inside surge protection, reverse polarity protection, overcurrent protection
- Long use-life cycle and high reliability, easy install, economic price
- Red LED status indication, easy to confirm work situation
- Protection structure IP67(IEC standard)
- Replaceable for limit switches

**Model Number Structure**

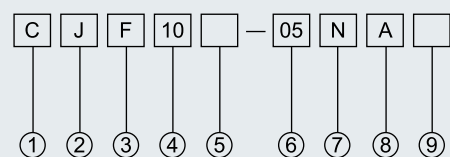

Item	Code	Description
① Company code	C	Company code
② Product name	J	Inductive proximity sensor
③ Shape of shell	F	Square
④ Dimension code	10	10=10 Square10
⑤ Product type	Without	High-end type
⑥ Detection distance	05	05=5mm
⑦ Output mode	K	AC 2wires
	L	DC 2wires
	P	PNP 3wires
	N	NPN 3wires
⑧ Output state	A	NO
	B	NC
	C	NO+NC
⑨ Connection	Without	Without: Lead wire
	T	Plug-in
	R	Wiring leads Plug-in

**Specifications**

Model	CJF10-05LA CJF10-05NA CJF10-05NB CJF10-05PA CJF10-05PB	CJF11-06LA CJF11-06NA CJF11-06NB CJF11-06PA CJF11-06PB	CJF12-07LA CJF12-07NA CJF12-07NB CJF12-07PA CJF12-07PB
Sensing distance	5mm	6mm	7mm
Hysteresis	Max. 10% of sensing distance		
Standard sensing target	25 × 25 × 1mm (Iron)		
Setting distance	0~3.5mm	0~3.5mm	0~5.5mm
Power supply (Operating voltage)	12-24VDC (10-30VDC)		
Leakage current	Max.10mA		
Response frequency (※1)	500Hz	500Hz	400Hz
Residual voltage	DC Second line: Max. 3.5V DC Three-line: Max. 1.0V		
Affection by Temp.	Max. ± 10% for sensing distance at ambient temperature 20℃		
Control output	Max. 200mA		
Insulation resistance	Min. 50MΩ (at 500VDC megger)		
Dielectric strength	1500VAC 50/60Hz for 1minute		
Vibration	1mm amplitude at frequency of 10 to 55Hz(for 1 min.) in each of X, Y, Z directions for 2 hours		
Shock	500m/s <sup>2</sup> (approx. 50G) X, Y, Z directions for 3 times		
Indicator	Operation indicator(red LED)		
Ambient temperature	-25~+70℃ (No icing)		
Storage temperature	-30~+80℃ (No icing)		
Ambient humidity	35~95%RH (No condensation)		
Protection circuit	Surge protection circuit, Reverse polarity protection circuit, Overcurrent protection circuit		
Cable	φ 3.8, 2P, 2m φ 3.8, 3P, 2m		
	(AWG22, Core diameter: 0.1mm, Number of cores: 25, Insulator diameter: φ 1.25)		
Material	Case: PBT, Standard cable(Grey): Polyvinyl chloride(PVC)		
Protection	IP67		

(※1): The response frequency is the average value. The standard sensing target is used and the width is set as 2 times of the standard sensing target, 1/2 of the sensing distance for the distance.



Appearance and Dimension

CJF10-05		
CJF11-06		
CJF12-07		

Control Output Diagram

DC 2-wire type

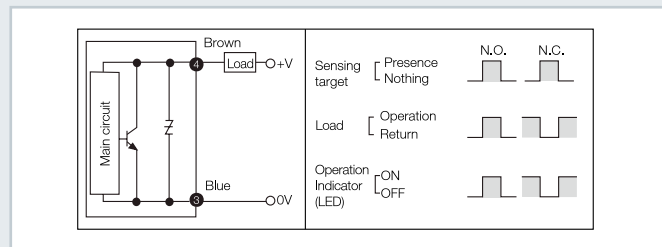

DC 3-wire type

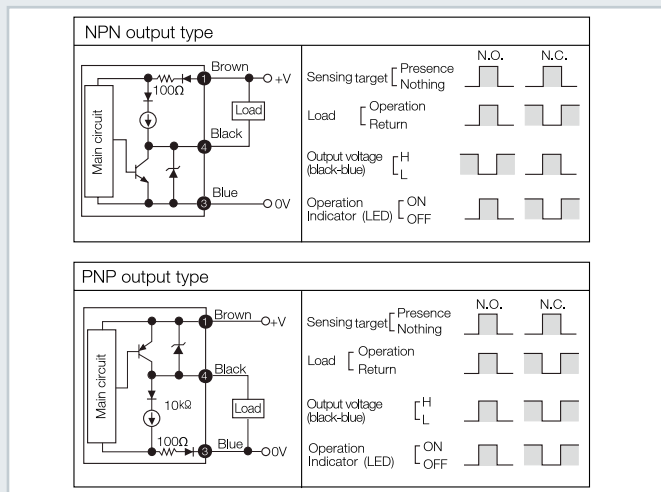

Proper Usage

Mutual-interference

When several proximity sensors are mounted close to one another a malfunction of the sensor may be caused due to mutual interference. Therefore, be sure to provide a minimum distance between the two sensors as below chart indicates.

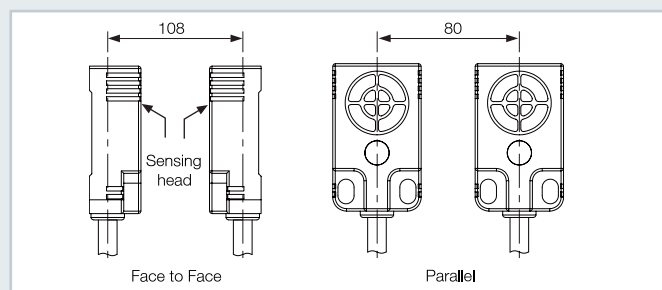

Influence by surrounding metals

When sensors are mounted on metallic panel, you must prevent the sensors from being affected by any metallic object except target. Therefore, be sure to provide a minimum distance as below chart indicates.

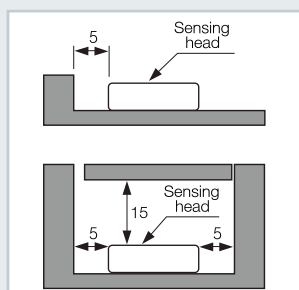

※ When the height between the proximity sensor and surrounding metals is same.

※ When the height between the proximity sensor and surrounding metals is different.



Features

- Inside surge protection, reverse polarity protection, overcurrent protection
- Long use-life cycle and high reliability, easy install, economic price
- Red LED status indication, easy to confirm work situation
- Protection structure IP67(IEC standard)
- Replaceable for limit switches

Model Number Structure

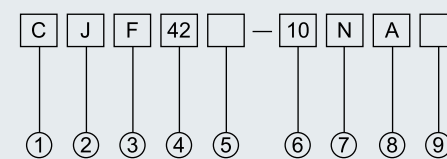

Item	Code	Description
① Company code	C	Company code
② Product name	J	Inductive proximity sensor
③ Shape of shell	F	Square
④ Dimension code	42	42=Φ42
⑤ Product type	Without	High-end type
⑦ Output mode	K	AC 2wires
	L	DC 2wires
	P	PNP 3wires
⑧ Output state	N	NPN 3wires
	A	NO
	B	NC
⑨ Connection	C	NO+NC
	Without	Without: Lead wire
	T	Plug-in
	R	Wiring leads Plug-in





Specifications

DC 3-wire type

Model	CJF36-07NA CJF36-07NB CJF36-07PA CJF36-07PB	CJF42-10NA CJF42-10NB CJF42-10PA CJF42-10PB	CJF48-15NA CJF48-15NB CJF48-15PA CJF48-15PB	CJF55-20NA CJF55-20NB CJF55-20PA CJF55-20PB
Sensing distance	7mm	10mm	15mm	20mm
Hysteresis	Max. 10% of sensing distance			
Standard sensing target	50 × 50 × 1mm (Iron)	55 × 55 × 1mm (Iron)	60 × 60 × 1mm (Iron)	80 × 80 × 1mm (Iron)
Setting distance	0~5.5mm	0~7.5mm	0~12.5mm	0~15.5mm
Power supply (Operating voltage)	12-24VDC (10-30VDC)			
Leakage current	Max. 10mA			
Response frequency (*1)	300Hz	200Hz	100Hz	100Hz
Residual voltage	Max. 1.0V			
Affection by Temp.	Max. ± 10% for sensing distance at ambient temperature 20℃			
Control output	Max. 200mA			
Insulation resistance	Min. 50MΩ (at 500VDC megger)			
Dielectric strength	1500VAC 50/60Hz for 1minute			
Vibration	1mm amplitude at frequency of 10 to 55Hz(for 1 min.) in each of X, Y, Z directions for 2 hours			
Shock	500m/s <sup>2</sup> (approx. 50G) X, Y, Z directions for 3 times			
Indicator	Operation indicator(red LED)			
Ambient temperature	-25~+70℃ (No icing)			
Storage temperature	-30~+80℃ (No icing)			
Ambient humidity	35~95%RH (No condensation)			
Protection circuit	Surge protection circuit, Reverse polarity protection circuit, Overcurrent protection circuit			
Cable	φ 3.8, 3P, 2m		φ 4.8, 3P, 2m	
	AWG22, Core diameter: 0.1mm, Number of cores: 25, Insulator diameter: φ 1.25		AWG22, Core diameter: 0.1mm, Number of cores: 30, Insulator diameter: φ 1.25	
Material	Case: PBT, Standard cable(Grey): Polyvinyl chloride(PVC)			
Protection	IP67			

(\*1): The response frequency is the average value. The standard sensing target is used and the width is set as 2 times of the standard sensing target, 1/2 of the sensing distance for the distance.

Specifications

DC 2-wire type

Model	CJF36-07LA CJF36-07LB	CJF42-10LA CJF42-10LB	CJF48-15LA CJF48-15LB	CJF55-20LA CJF55-20LB
Sensing distance	7mm	10mm	15mm	20mm
Hysteresis	Max. 10% of sensing distance			
Standard sensing target	50 × 50 × 1mm (Iron)	55 × 55 × 1mm (Iron)	60 × 60 × 1mm (Iron)	80 × 80 × 1mm (Iron)
Setting distance	0~5.5mm	0~7.5mm	0~12.5mm	0~15.5mm
Power supply (Operating voltage)	12-24VDC (10-30VDC)			
Leakage current	Max. 0.6mA			
Response frequency (*1)	300Hz	200Hz	100Hz	100Hz
Residual voltage	Max. 3.5V			
Affection by Temp.	Max. ± 10% for sensing distance at ambient temperature 20℃			
Control output	Max. 200mA			
Insulation resistance	Min. 50MΩ (at 500VDC megger)			
Dielectric strength	1500VAC 50/60Hz for 1minute			
Vibration	1mm amplitude at frequency of 10 to 55Hz(for 1 min.) in each of X, Y, Z directions for 2 hours			
Shock	500m/s <sup>2</sup> (approx. 50G) X, Y, Z directions for 3 times			
Indicator	Operation indicator(red LED)			
Ambient temperature	-25~+70℃ (No icing)			
Storage temperature	-30~+80℃ (No icing)			
Ambient humidity	35~95%RH (No condensation)			
Protection circuit	Surge protection circuit, Reverse polarity protection circuit, Overcurrent protection circuit			
Cable	φ 3.8, 2P, 2m		φ 4.8, 2P, 2m	
	AWG22, Core diameter: 0.1mm, Number of cores: 25, Insulator diameter: φ 1.25		AWG22, Core diameter: 0.1mm, Number of cores: 30, Insulator diameter: φ 1.25	
Material	Case: PBT, Standard cable(Grey): Polyvinyl chloride(PVC)			
Protection	IP67			

(\*1): The response frequency is the average value. The standard sensing target is used and the width is set as 2 times of the standard sensing target, 1/2 of the sensing distance for the distance.



Specifications

AC 2-wire type

Model	CJF42-10KA CJF42-10KB	CJF48-15KA CJF48-15KB	CJF55-20KA CJF55-20KB
Sensing distance	10mm	15mm	20mm
Hysteresis	Max. 10% of sensing distance		
Standard sensing target	55 × 55 × 1mm (Iron)	60 × 60 × 1mm (Iron)	80 × 80 × 1mm (Iron)
Setting distance	0~7.5mm	0~12.5mm	0~15.5mm
Power supply (Operating voltage)	24-250VAC		
Leakage current	Max. 10mA		
Response frequency (※1)	20Hz		
Residual voltage	Max. 10V		
Affection by Temp.	Max. ± 10% for sensing distance at ambient temperature 20°C		
Control output	Max. 200mA		
Insulation resistance	Min. 50MΩ (at 500VDC megger)		
Dielectric strength	1500VAC 50/60Hz for 1minute		
Vibration	1mm amplitude at frequency of 10 to 55Hz(for 1 min.) in each of X, Y, Z directions for 2 hours		
Shock	500m/s <sup>2</sup> (approx. 50G) X, Y, Z directions for 3 times		
Indicator	Operation indicator(red LED)		
Ambient temperature	-25~+70°C (No icing)		
Storage temperature	-30~+80°C (No icing)		
Ambient humidity	35~95%RH (No condensation)		
Protection circuit	Surge protection circuit		
Cable	φ 3.8, 2P, 2m	φ 4.8, 2P, 2m	
	(AWG22, Core diameter: 0.1mm, Number of cores: 25, Insulator diameter: φ 1.25)	(AWG22, Core diameter: 0.1mm, Number of cores: 30, Insulator diameter: φ 1.25)	
Material	Case: PBT, Standard cable(Grey): Polyvinyl chloride(PVC)		
Protection	IP67		

(※1): The response frequency is the average value. The standard sensing target is used and the width is set as 2 times of the standard sensing target, 1/2 of the sensing distance for the distance.

Appearance and Dimension

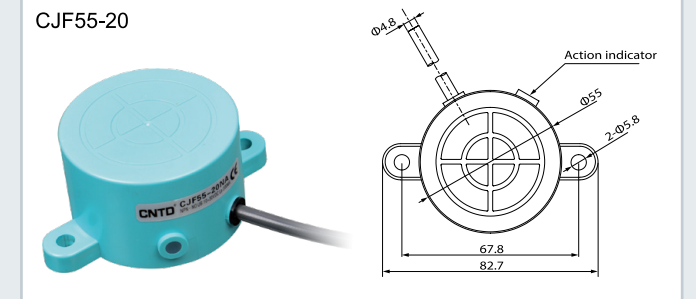
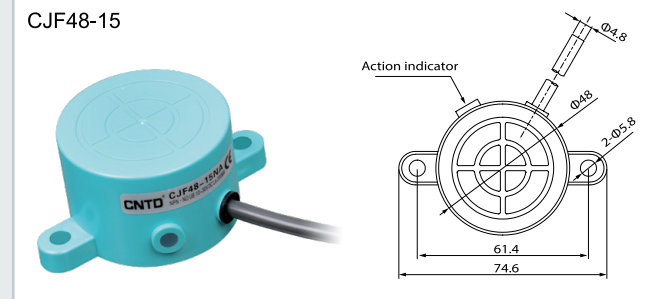
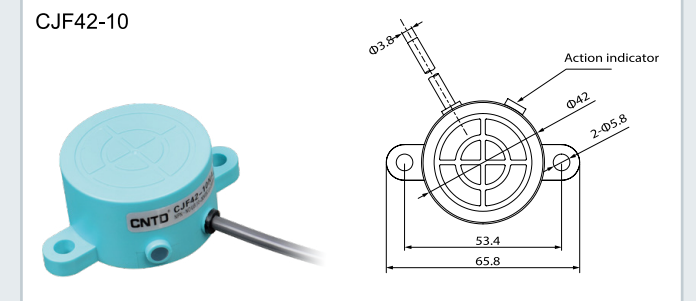
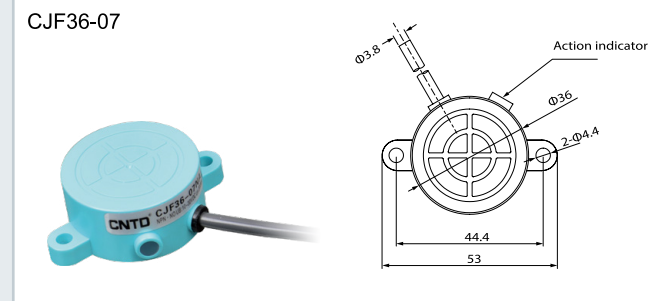

Control Output Diagram

DC 2-wire type

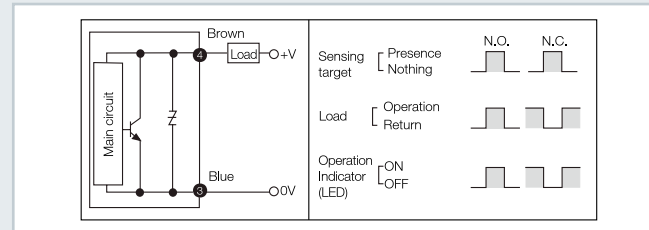

DC 3-wire type

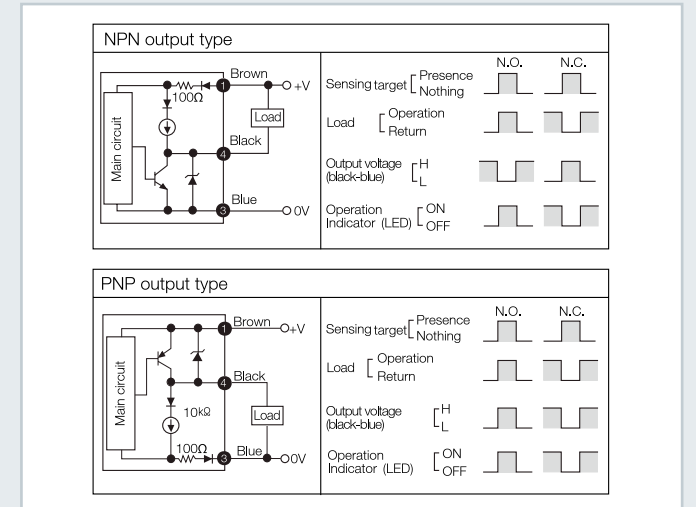

AC 2-wire type

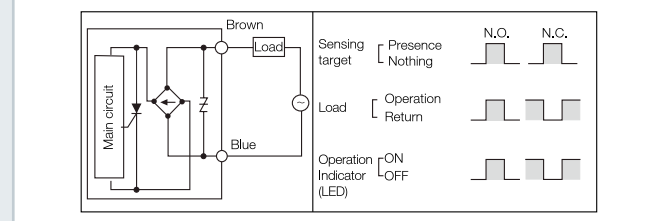

Connections

DC 2-wire type

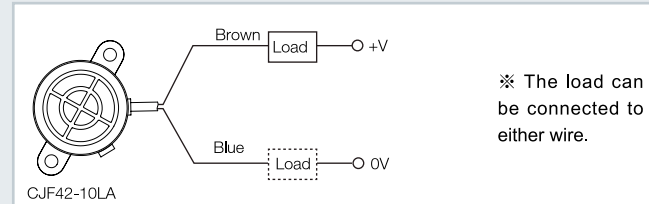

AC 2-wire type

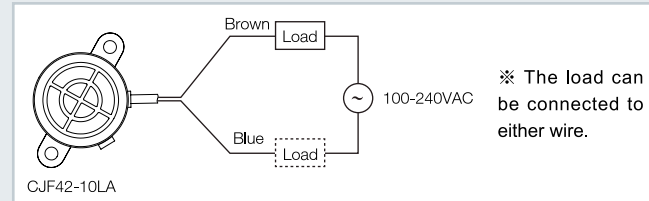

DC 3-wire type

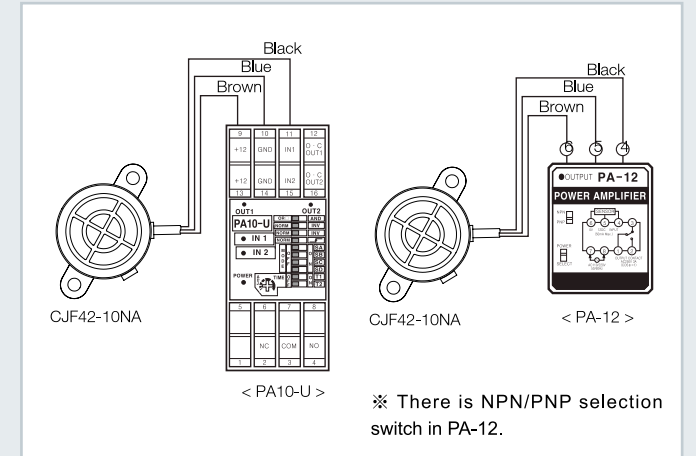





**Features**

- Long sensing distance 50mm
- Exclusively designed IC for improving anti-jamming capability
- Inside surge protection, reverse polarity protection, overcurrent protection
- Red LED status indication, easy to confirm work situation
- Protection structure IP65(IEC standard)

**Model Number Structure**

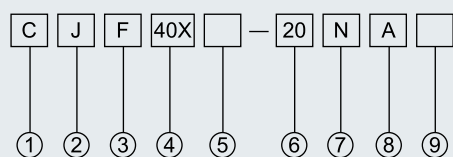

Item	Code	Description
① Company code	C	Company code
② Product name	J	Inductive proximity sensor
③ Shape of shell	F	Square
④ Dimension code	40X	40X=Rectangle 40
⑤ Product type	Without	High-end type
⑦ Output mode	K	AC 2wires
	L	DC 2wires
	P	PNP 3wires
	N	NPN 3wires
⑧ Output state	A	NO
	B	NC
	C	NO+NC
⑨ Connection	Without	Without: Lead wire
	T	Plug-in
	R	Wiring leads Plug-in

**Specifications**

Model	CJF40X-20LA CJF40X-20LB CJF40X-20NA CJF40X-20NB CJF40X-20PA CJF40X-20PB CJF40X-20KA CJF40X-20KB	CJF40Y-20LA CJF40Y-20LB CJF40Y-20NA CJF40Y-20NB CJF40Y-20PA CJF40Y-20PB CJF40Y-20KA CJF40Y-20KB	CJF80-50LA CJF80-50LB CJF80-50NA CJF80-50NB CJF80-50PA CJF80-50PB CJF80-50KA CJF80-50KB
Sensing distance	20mm	20mm	50mm
Hysteresis	Max. 10% of sensing distance		
Standard sensing target	75 × 75 × 1mm (Iron)	75 × 75 × 1mm (Iron)	120 × 120 × 1mm (Iron)
Setting distance	0~15.5mm	0~15.5mm	0~40mm
Power supply (Operating voltage)	10-30VDC / 24-250VAC		
Leakage current	Max.10mA		
Response frequency (※1)	DC 200Hz / AC 20Hz		
Residual voltage	DC second line: Max. 3.5V DC three-wire: Max. 1.0V AC two-wire: below 10V Max. 10V		
Affection by Temp.	Max. ± 10% for sensing distance at ambient temperature 20℃		
Control output	Max. 200mA		
Insulation resistance	Min. 50MΩ (at 500VDC megger)		
Dielectric strength	1500VAC 50/60Hz for 1minute		
Vibration	1mm amplitude at frequency of 10 to 55Hz(for 1 min.) in each of X, Y, Z directions for 2 hours		
Shock	500m/s <sup>2</sup> (approx. 50G) X, Y, Z directions for 3 times		
Indicator	Operation indicator(red LED)		
Ambient temperature	-25~+70℃ (No icing)		
Storage temperature	-30~+80℃ (No icing)		
Ambient humidity	35~95%RH (No condensation)		
Protection circuit	Surge protection circuit, Reverse polarity protection circuit, Overcurrent protection circuit		
Material	Case: PBT, Standard cable(Grey): Polyvinyl chloride(PVC)		
Protection	IP65		

(※1): The response frequency is the average value. The standard sensing target is used and the width is set as 2 times of the standard sensing target, 1/2 of the sensing distance for the distance.

Appearance and Dimension

CJF40Y-20

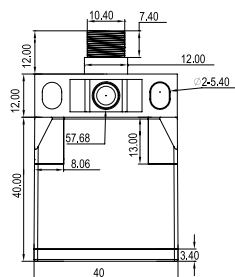

CJF40X-20

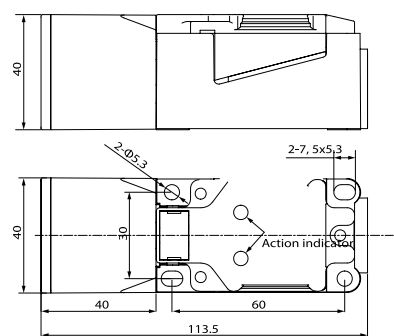
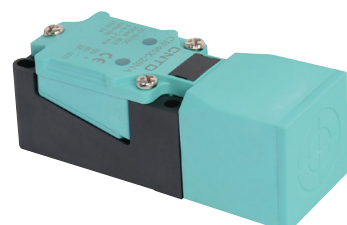

CJF80-50

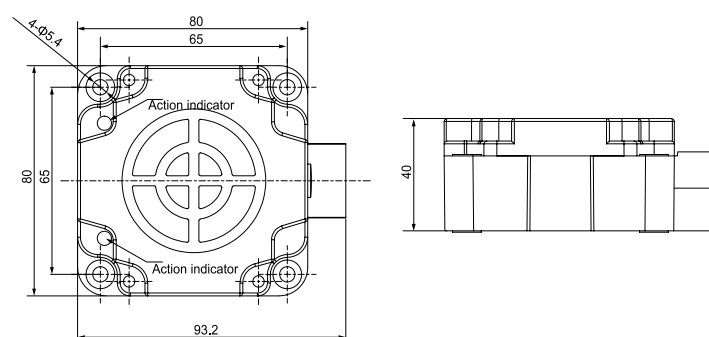

Control Output Diagram

DC 3-wire type

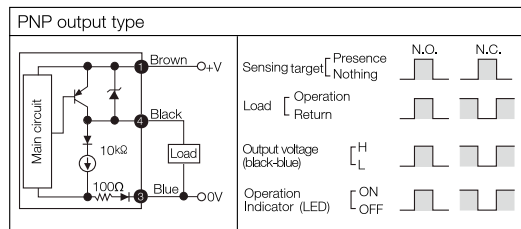
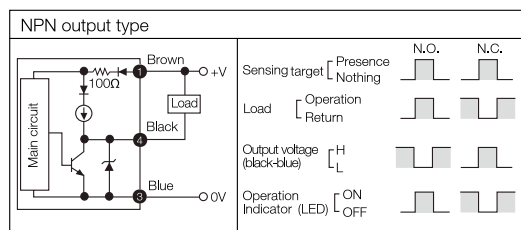

AC 2-wire type

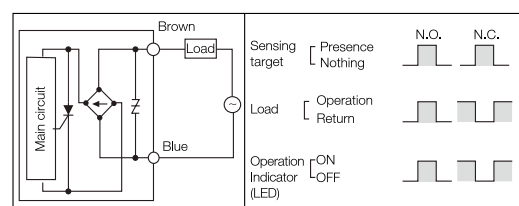

Features

- Inside surge protection, reverse polarity protection
- Long use-life cycle and high reliability, easy install, economic price
- Red LED status indication, easy to confirm work situation
- Protection structure IP65(IEC standard)

Model Number Structure

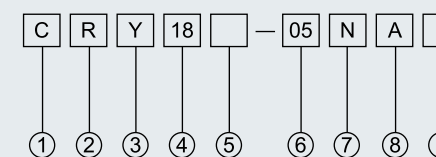

Item	Code	Description
① Company code	C	Company code
② Product name	R	Capacitive proximity sensor
③ Shape of shell	Y	Cylinder-shaped
④ Dimension code	18	18=M18
⑤ Product type	Without	High-end type
⑥ Detection distance	05	05=5mm
	K	AC 2wires
	L	DC 2wires
	P	PNP 3wires
⑦ Output mode	N	NPN 3wires
	A	NO
	B	NC
⑧ Output state	C	NO+NC
	Without	Without: Lead wire
	T	Plug-in
⑨ Connection	R	Wiring leads Plug-in



Specifications

DC 3wire type

Model	CRY12-02NA CRY12-02NB CRY12-02PA CRY12-02PB	CRY12-04NA CRY12-04NB CRY12-04PA CRY12-04PB	CRY18-05NA CRY18-05NB CRY18-05NC CRY18-05PA CRY18-05PB CRY18-05PC	CRY18-08NA CRY18-08NB CRY18-08NC CRY18-08PA CRY18-08PB CRY18-08PC	CRY30-10NA CRY30-10NB CRY30-10NC CRY30-10PA CRY30-10PB CRY30-10PC	CRY30-15NA CRY30-15NB CRY30-15NC CRY30-15PA CRY30-15PB CRY30-15PC
Sensing distance	2mm	4mm	5mm	8mm	10mm	15mm
Hysteresis	Max. 10% of sensing distance					
Setting distance	0~1.4mm	0~2.8mm	0~3.5mm	0~5.6mm	0~7mm	0~10.5mm
Power supply (Operating voltage)	12-24VDC (10-30VDC)					
Leakage current	Max.10mA					
Response frequency (*1)	50Hz					
Residual voltage	Max. 1.0V					
Affection by Temp.	Max. ± 10% for sensing distance at ambient temperature 20℃					
Control output	Max. 200mA					
Insulation resistance	Min. 50MΩ (at 500VDC megger)					
Dielectric strength	1500VAC 50/60Hz for 1minute					
Vibration	1mm amplitude at frequency of 10 to 55Hz(for 1 min.) in each of X, Y, Z directions for 2 hours					
Shock	500m/s <sup>2</sup> (approx. 50G) X, Y, Z directions for 3 times					
Indicator	Operation indicator(red LED)					
Ambient temperature	-25~+60℃ (No icing)					
Storage temperature	-30~+80℃ (No icing)					
Ambient humidity	35~95%RH (No condensation)					
Protection circuit	Surge protection circuit, Overcurrent protection circuit					
Material	Case/Nut: ABS, Washer: Plastic, Sensing surface: PBT, Standard cable(Gray): Polyvinyl chloride(PVC), Oil resistant cable(Black): Oil resistant Polyvinyl chloride(PVC)					
Cable	φ 3.8, 3P, 2m (AWG22, Core diameter: 0.1mm, Number of cores: 25, Insulator diameter: φ 1.25		φ 4.8, 3P,4P 2m (AWG22, Core diameter: 0.1mm, Number of cores: 30, Insulator diameter: φ 1.25			
Protection	IP65					

Specifications

AC 2wire type

Model	CRY18-05KA CRY18-05KB	CRY18-08KA CRY18-08KB	CRY30-10KA CRY30-10KB	CRY30-15KA CRY30-15KB
Sensing distance	5mm	8mm	10mm	15mm
Hysteresis	Max. 10% of sensing distance			
Setting distance	0~3.5mm	0~5.6mm	0~7mm	0~10.5mm
Power supply (Operating voltage)	90-250VAC			
Leakage current	Max.10mA			

Specifications

AC 2wire type

Model	CRY18-05KA CRY18-05KB	CRY18-08KA CRY18-08KB	CRY30-10KA CRY30-10KB	CRY30-15KA CRY30-15KB
Response frequency (*1)	50Hz			
Residual voltage	Max. 10V			
Affection by Temp.	Max. ± 10% for sensing distance at ambient temperature 20℃			
Control output	Max. 200mA			
Insulation resistance	Min. 50MΩ (at 500VDC megger)			
Dielectric strength	1500VAC 50/60Hz for 1minute			
Vibration	1mm amplitude at frequency of 10 to 55Hz(for 1 min.) in each of X, Y, Z directions for 2 hours			
Shock	500m/s <sup>2</sup> (approx. 50G) X, Y, Z directions for 3 times			
Indicator	Operation indicator(red LED)			
Ambient temperature	-25~+60℃ (No icing)			
Storage temperature	-30~+80℃ (No icing)			
Ambient humidity	35~95%RH (No condensation)			
Protection circuit	Surge protection circuit,			
Material	Case/Nut: ABS, Sensing surface: PBT, Standard cable(Gray): Polyvinyl chloride(PVC), Oil resistant cable(Black): Oil resistant Polyvinyl chloride(PVC)			
Cable	φ 4.8, 2P, 2m (AWG22, Core diameter: 0.1mm, Number of cores: 30, Insulator diameter: φ 1.25			
Protection	IP65			

Appearance and Dimension

CRY12

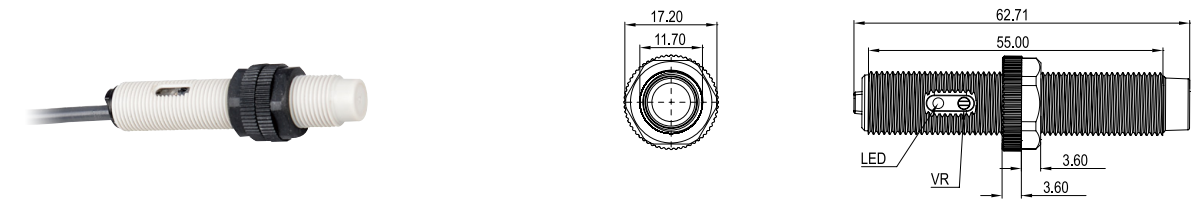

CRY18

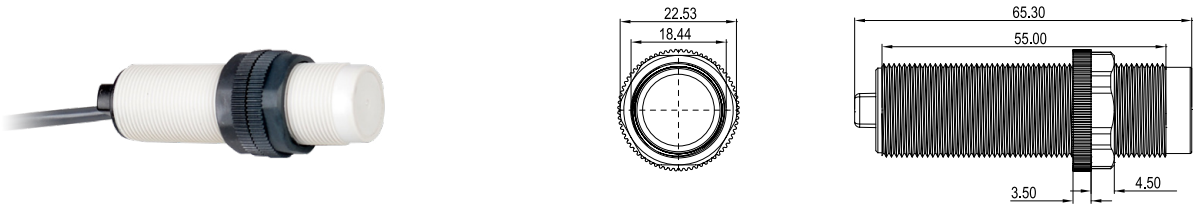

CRY30

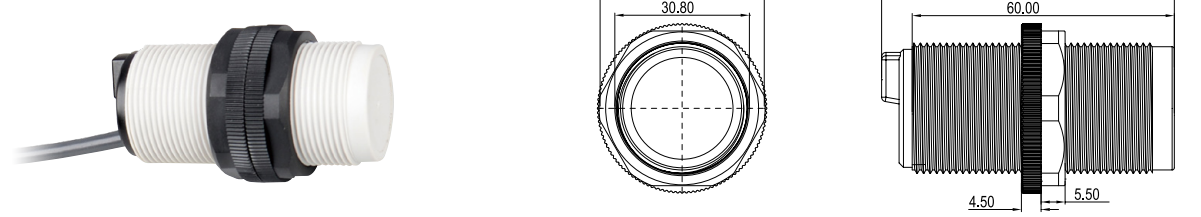

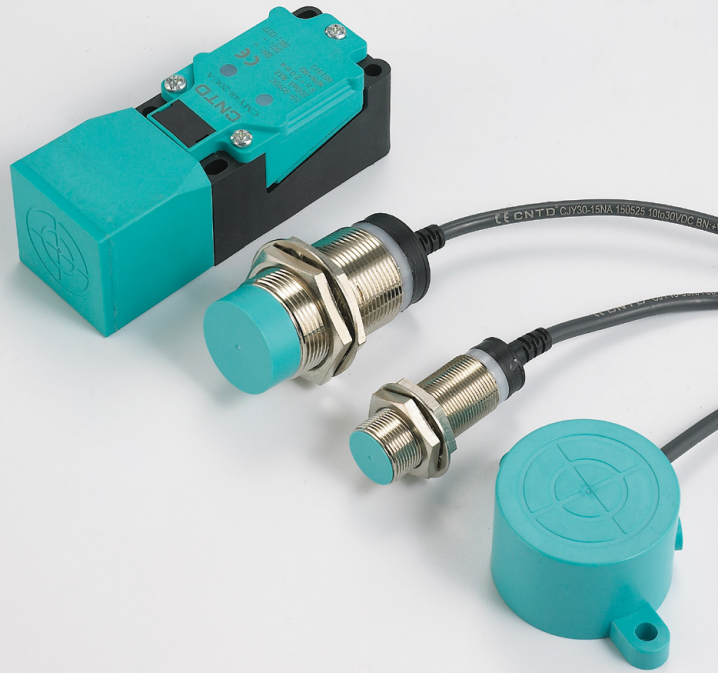

**Features**

- Inside surge protection, reverse polarity protection
- Long use-life cycle and high reliability, easy install, economic price
- Red LED status indication, easy to confirm work situation
- Protection structure IP65(IEC standard)

**Model Number Structure**

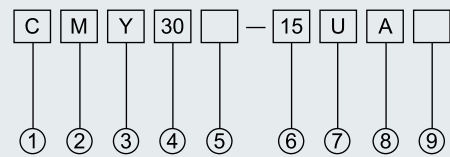

Item	Code	Description
① Company code	C	Company code
② Product name	M	Analog proximity sensor
③ Shape of shell	Y	Cylinder-shaped
④ Dimension code	30	30=M30
⑤ Product type	Without	High-end type
	E	Standard type
⑥ Detection distance	15	15=15mm
⑦ Output mode	U	Voltage mode
	I	Current mode
⑧ Output state	A	NO
	B	NC
	C	NO+NC
⑨ Connection	Without	Without: Lead wire
	T	Plug-in
	R	Wiring leads Plug-in

**Specifications**

Model	CMY18-08U CMY18-08 I	CMY30-15U CMY30-15 I	CMF40-20U CMF40-20 I	CMF48-20U CMF48-20 I
Sensing distance	1-8mm	1-15mm	1-20mm	1-20mm
Hysteresis	3-20%			
Power supply (Operating voltage)	15-30VDC			
Affection by Temp.	Max. ± 10% for sensing distance at ambient temperature 20℃			
Control output	Output voltage / Current output			
Insulation resistance	Min. 50MΩ (at 500VDC megger)			
Dielectric strength	1500VAC 50/60Hz for 1minute			
Vibration	1mm amplitude at frequency of 10 to 55Hz(for 1 min.) in each of X, Y, Z directions for 2 hours			
Shock	500m/s <sup>2</sup> (approx. 50G) X, Y, Z directions for 3 times			
Indicator	Operation indicator(red LED)			
Ambient temperature	-15~+55℃ (No icing)			
Storage temperature	-15~+55℃ (No icing)			
Ambient humidity	35~95%RH (No condensation)			
Protection circuit	Surge protection circuit, Overcurrent protection circuit			
Material	Case/Nut: Plastic, Washer: Plastic, Sensing surface: PBT, Standard cable(Gray): Polyvinyl chloride(PVC), Oil resistant cable(Black): Oil resistant Polyvinyl chloride(PVC)			
Cable	φ 3.8, 2P, 2m		φ 4.8, 2P, 2m	
	(AWG22, Core diameter: 0.1mm, Number of cores: 25, Insulator diameter: φ 1.25		(AWG22, Core diameter: 0.1mm, Number of cores: 30, Insulator diameter: φ 1.25	
Protection	IP65			

**Appearance and Dimension**

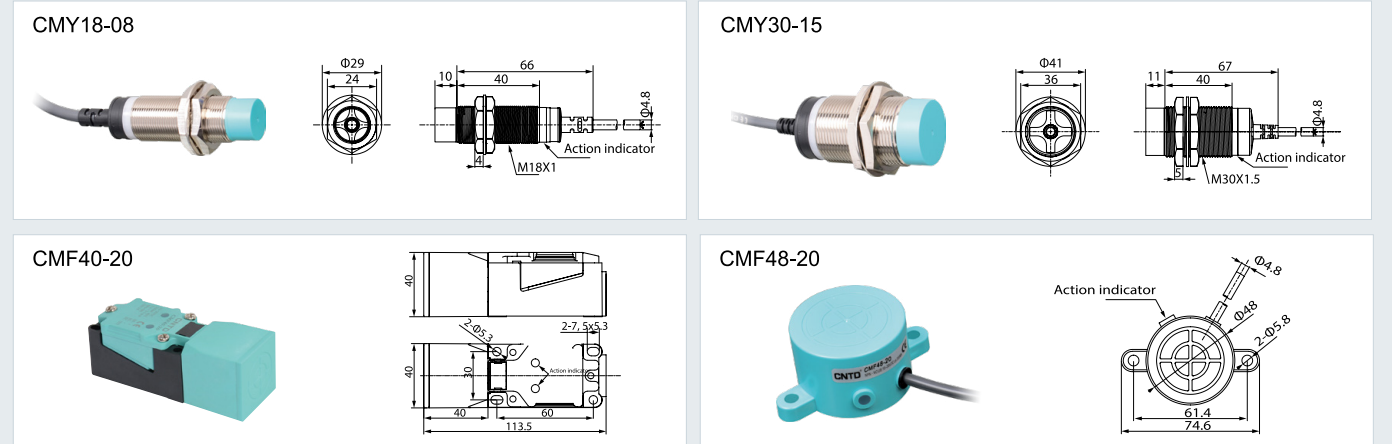



Features

- Inside surge protection, reverse polarity protection
- Long use-life cycle and high reliability, easy install, economic price
- Red LED status indication, easy to confirm work situation
- Protection structure IP67(IEC standard)

Model Number Structure

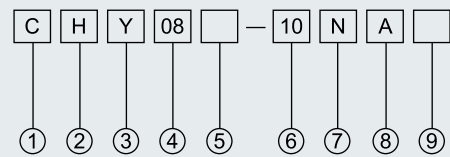

Item	Code	Description
① Company code	C	Company code
② Product name	H	Hall sensor
③ Shape of shell	Y	Cylinder-shaped
④ Dimension code	08	08=M08
⑤ Product type	Without	High-end type
⑦ Output mode	P	PNP 3wires
	N	NPN 3wires
	A	NO
⑧ Output state	B	NC
	C	NO+NC
	Without	Without: Lead wire
⑨ Connection	T	Plug-in
	R	Wiring leads Plug-in

Specifications

Model	CHY08-10NA CHY08-10NB	CHY08-10PA CHY08-10PB	CHY12-10NA CHY12-10NB CHY12-10NC	CHY12-10PA CHY12-10PB CHY12-10PC	CHY18-10NA CHY18-10NB CHY18-10NC	CHY18-10PA CHY18-10PB CHY18-10PC
Sensing distance	10mm		10mm		10mm	
Hysteresis	3-20%					
Consumption current	Max. 10mA					
Power supply (Operating voltage)	6-36VDC					
Response frequency	1000Hz					
Residual voltage	Max. 1V					
Affection by Temp.	Max. ± 10% for sensing distance at ambient temperature 20℃					
Control output	Max. 200mA					
Insulation resistance	Min. 50MΩ (at 500VDC megger)					
Dielectric strength	1500VAC 50/60Hz for 1minute					
Vibration	1mm amplitude at frequency of 10 to 55Hz(for 1 min.) in each of X, Y, Z directions for 2 hours					
Shock	500m/s <sup>2</sup> (approx. 50G) X, Y, Z directions for 3 times					
Indicator	Operation indicator(red LED)					
Ambient temperature	-15~+55℃ (No icing)					
Storage temperature	-15~+55℃ (No icing)					
Ambient humidity	35~95%RH (No condensation)					
Protection circuit	Surge protection circuit, Overcurrent protection circuit					
Material	Case/Nut: Nickel plated Brass, Washer: Nickel plated Iron, Sensing surface: PBT, Standard cable(Gray): Polyvinyl chloride(PVC), Oil resistant cable(Black): Oil resistant Polyvinyl chloride(PVC)					
Cable	φ 2.8, 3P, 2m		φ 3.8, 3P, 4P 2m		φ 4.8, 3P, 4P 2m	
	(AWG22, Core diameter: 0.1mm, Number of cores: 22, Insulator diameter: φ 1.25		(AWG22, Core diameter: 0.1mm, Number of cores: 25, Insulator diameter: φ 1.25		(AWG22, Core diameter: 0.1mm, Number of cores: 30, Insulator diameter: φ 1.25	
Protection	IP67					

Appearance and Dimension

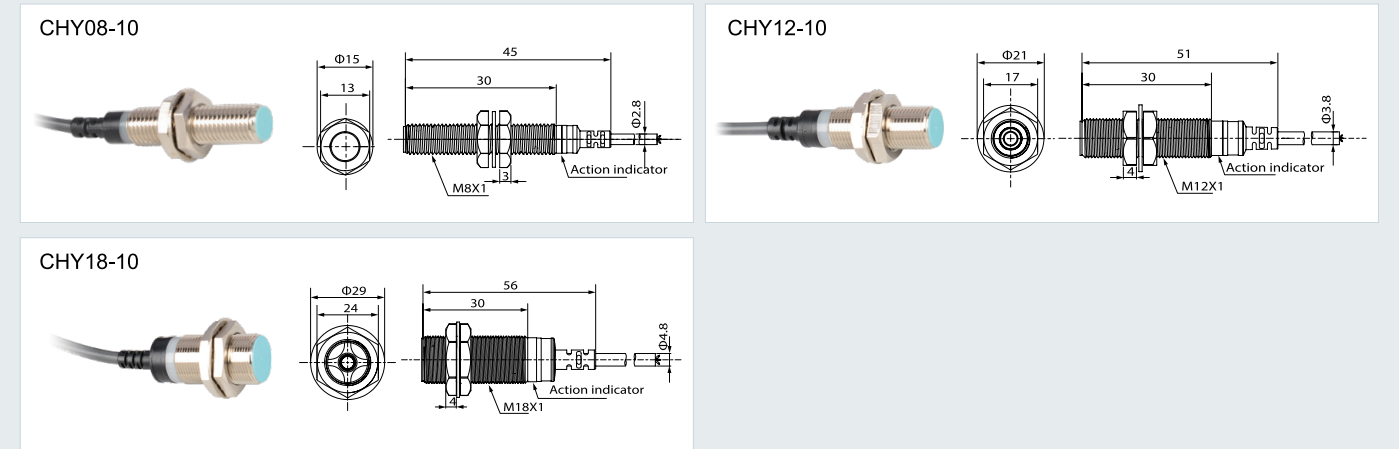





**Features**

- Inside surge protection, reverse polarity protection
- Long use-life cycle and high reliability, easy install, economic price
- Red LED status indication, easy to confirm work situation
- Protection structure IP67(IEC standard)

**Model Number Structure**

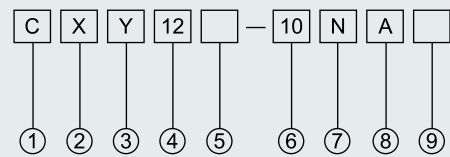

Item	Code	Description
① Company code	C	Company code
② Product name	X	Magnetic sensor
③ Shape of shell	Y	Cylinder-shaped
④ Dimension code	12	12=M12
⑤ Product type	Without	High-end type
⑥ Detection distance	10	10=10mm
	K	AC 2 wires
⑦ Output mode	L	DC 2 wires
	A	NO
⑧ Output state	B	NC
	C	NO+NC
	Without	Without: Lead wire
⑨ Connection	T	Plug-in
	R	Wiring leads Plug-in

**Specifications**

Model	CXY08-10LA CXY08-10KA	CXY12-10LA CXY12-10KA	CXY18-10LA CXY18-10KA	CXF18-10LA CXF18-10KA
Sensing distance	10mm	10mm	10mm	10mm
Hysteresis	3-20%			
Consumption current	Max. 10mA			
Power supply (Operating voltage)	12-240VDC/AC			
Response frequency	100Hz			
Residual voltage	Max. 3V			
Affection by Temp.	Max. ± 10% for sensing distance at ambient temperature 20℃			
Control output	Max. 200mA			
Insulation resistance	Min. 50MΩ (at 500VDC megger)			
Dielectric strength	1500VAC 50/60Hz for 1minute			
Vibration	1mm amplitude at frequency of 10 to 55Hz(for 1 min.) in each of X, Y, Z directions for 2 hours			
Shock	500m/s <sup>2</sup> (approx. 50G) X, Y, Z directions for 3 times			
Indicator	Operation indicator(red LED)			
Ambient temperature	-15~+55℃ (No icing)			
Storage temperature	-15~+55℃ (No icing)			
Ambient humidity	35~95%RH (No condensation)			
Protection circuit	Surge protection circuit			
Material	Case/Nut: Nickel plated Brass, Washer: Nickel plated Iron, Sensing surface: PBT, Standard cable(Gray): Polyvinyl chloride(PVC), Oil resistant cable(Black): Oil resistant Polyvinyl chloride(PVC)			
Cable	φ 2.8, 2P, 2m	φ 3.8, 2P, 2m	φ 4.8, 2P, 2m	
	(AWG22, Core diameter: 0.1mm, Number of cores: 22, Insulator diameter: φ 1.25	(AWG22, Core diameter: 0.1mm, Number of cores: 25, Insulator diameter: φ 1.25	(AWG22, Core diameter: 0.1mm, Number of cores: 30, Insulator diameter: φ 1.25	
Protection	IP67			

**Appearance and Dimension**

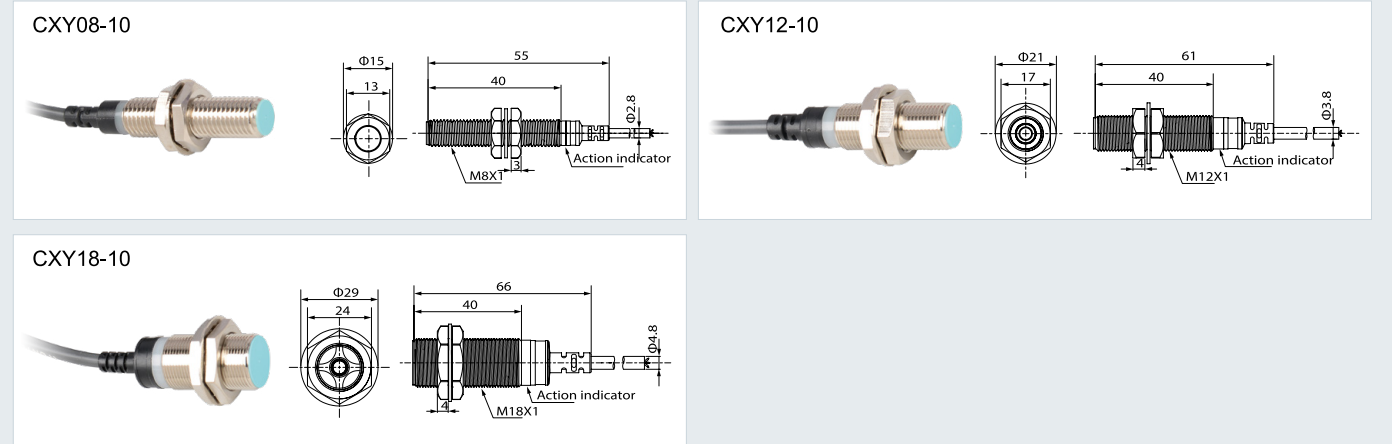



Features

- Dark grey mark for standard type
- Blue green mark for high-end type
- Exclusively designed IC for improving anti-jamming capability
- Inside surge protection, reverse polarity protection
- Long use-life cycle and high reliability, easy install, economic price
- Red LED status indication, easy to confirm work situation
- Protection structure IP65(IEC standard)



■ Rice white



■ Dark grey

Model Number Structure

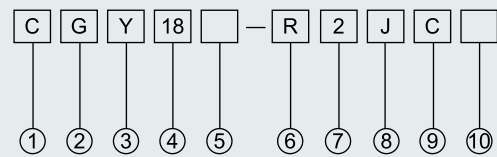

Item	Code	Description
① Company code	C	Company code
② Product name	G	Photoelectric sensor
③ Shape of shell	Y	Cylinder-shaped
④ Dimension code	18	18=M18
⑤ Product type	Without	Without =High-end type (Dark grey)
	E	E=Standard type (Rice white)
⑥ Installation form	D	Diffuse-reflective type
	R	Retro-reflective type
	T	Through-bethod type
⑦ Detection distance	2	2=2m
⑧ Output mode	K	AC 2wires
	P	PNP 3wires
	N	NPN 3wires
	J	Relay
⑨ Output state	A	NO
	B	NC
	C	NO+NC
⑩ Connection	Without	Without: Lead wire
	T	Plug-in
	R	Wiring leads Plug-in

Note: Shell nuts can be customized nickel plated brass material, product model plus (-B), example: CGY18-R2JC-B.

Specifications

Diffuse-reflective type

Model	High-end type	CGY12-D05NA CGY12-D05NB CGY12-D05PA CGY12-D05PB	CGY12-D10NA CGY12-D10NB CGY12-D10PA CGY12-D10PB	CGY18-D10NA CGY18-D10NB CGY18-D10NC CGY18-D10PA CGY18-D10PB CGY18-D10PC CGY18-D10KA CGY18-D10KB	CGY18-D30NA CGY18-D30NB CGY18-D30NC CGY18-D30PA CGY18-D30PB CGY18-D30PC CGY18-D30KA CGY18-D30KB	CGY30-D50NA CGY30-D50NB CGY30-D50NC CGY30-D50PA CGY30-D50PB CGY30-D50PC CGY30-D50KA CGY30-D50KB	CGY30-D70NA CGY30-D70NB CGY30-D70NC CGY30-D70PA CGY30-D70PB CGY30-D70PC CGY30-D70KA CGY30-D70KB
	Standard type	CGY12E-D05NA CGY12E-D05NB CGY12E-D05PA CGY12E-D05PB	CGY12E-D10NA CGY12E-D10NB CGY12E-D10PA CGY12E-D10PB	CGY18E-D10NA CGY18E-D10NB CGY18E-D10NC CGY18E-D10PA CGY18E-D10PB CGY18E-D10PC CGY18E-D10KA CGY18E-D10KB	CGY18E-D30NA CGY18E-D30NB CGY18E-D30NC CGY18E-D30PA CGY18E-D30PB CGY18E-D30PC CGY18E-D30KA CGY18E-D30KB	CGY30E-D50NA CGY30E-D50NB CGY30E-D50NC CGY30E-D50PA CGY30E-D50PB CGY30E-D50PC CGY30E-D50KA CGY30E-D50KB	CGY30E-D70NA CGY30E-D70NB CGY30E-D70NC CGY30E-D70PA CGY30E-D70PB CGY30E-D70PC CGY30E-D70KA CGY30E-D70KB
Sensing distance	5cm	10cm (Adjustable)	10cm	30cm (Adjustable)	50cm	70cm (Adjustable)	
Hysteresis	3-20%						
Light source	Infrared LED (880nm)						
Consumption current	Max. 25mA						
Power supply (Operating voltage)	10-30VDC / 90-250VAC						
Response time	< 8.2ms						
Residual voltage	DC Max. 1V / AC Max. 10V						
Affection by Temp.	Max. ± 10% for sensing distance at ambient temperature 20℃						
Control output	Max. 200mA						
Insulation resistance	Min. 50MΩ (at 500VDC megger)						
Dielectric strength	1500VAC 50/60Hz for 1minute						
Vibration	1mm amplitude at frequency of 10 to 55Hz(for 1 min.) in each of X, Y, Z directions for 2 hours						
Shock	500m/s <sup>2</sup> (approx. 50G) X, Y, Z directions for 3 times						
Indicator	Operation indicator(red LED)						
Ambient temperature	-15~+55℃ (No icing)						
Storage temperature	-15~+55℃ (No icing)						
Ambient humidity	35~95%RH (No condensation)						
Protection circuit	Surge protection circuit, Overcurrent protection circuit						
Material	Case/Nut: ABS, Sensing surface: PMMA, Standard cable(Gray): Polyvinyl chloride(PVC), Oil resistant cable(Black): Oil resistant Polyvinyl chloride(PVC)						
Cable	High-end type	φ 3.8, 3P, 2m (AWG22, Core diameter: 0.1mm, Number of cores: 25, Insulator diameter: φ 1.25)		φ 4.8, 2P,3P,4P 2m (AWG22, Core diameter: 0.1mm, Number of cores: 30, Insulator diameter: φ 1.25)			
	Standard type	φ 3.8, 3P, 1.5m (AWG22, Core diameter: 0.1mm, Number of cores: 25, Insulator diameter: φ 1.25)		φ 4.8, 2P,3P,4P 1.5m (AWG22, Core diameter: 0.1mm, Number of cores: 30, Insulator diameter: φ 1.25)			
Protection	IP65						





Specifications

Retro-reflective type

Model	High-end type	CGY12-R1NA CGY12-R1NB CGY12-R1PA CGY12-R1PB	CGY18-R2NA CGY18-R2NB CGY18-R2NC CGY18-R2PA CGY18-R2PB CGY18-R2PC CGY18-R2KA CGY18-R2KB	CGY30-R4NA CGY30-R4NB CGY30-R4NC CGY30-R4PA CGY30-R4PB CGY30-R4PC CGY30-R4KA CGY30-R4KB
	Standard type	CGY12E-R1NA CGY12E-R1NB CGY12E-R1PA CGY12E-R1PB	CGY18E-R2NA CGY18E-R2NB CGY18E-R2NC CGY18E-R2PA CGY18E-R2PB CGY18E-R2PC CGY18E-R2KA CGY18E-R2KB	CGY30E-R4NA CGY30E-R4NB CGY30E-R4NC CGY30E-R4PA CGY30E-R4PB CGY30E-R4PC CGY30E-R4KA CGY30E-R4KB
Sensing distance		1m	2m	4m
Hysteresis		3-20%		
Light source		Infrared LED (880nm)		
Consumption current		Max. 25mA		
Power supply (Operating voltage)		10-30VDC / 90-250VAC		
Response time		< 8.2ms		
Reflector		TD02		TD08
Residual voltage		DC Max. 1V / AC Max. 10V		
Affection by Temp.		Max. ± 10% for sensing distance at ambient temperature 20°C		
Control output		Max. 200mA		
Insulation resistance		Min. 50MΩ (at 500VDC megger)		
Dielectric strength		1500VAC 50/60Hz for 1minute		
Vibration		1mm amplitude at frequency of 10 to 55Hz(for 1 min.) in each of X, Y, Z directions for 2 hours		
Shock		500m/s <sup>2</sup> (approx. 50G) X, Y, Z directions for 3 times		
Indicator		Operation indicator(red LED)		
Ambient temperature		-15~+55°C (No icing)		
Storage temperature		-15~+55°C (No icing)		
Ambient humidity		35~95%RH (No condensation)		
Protection circuit		Surge protection circuit, Overcurrent protection circuit		
Material		Case/Nut: ABS, Washer: Plastic, Sensing surface: PMMA, Standard cable(Gray): Polyvinyl chloride(PVC), Oil resistant cable(Black): Oil resistant Polyvinyl chloride(PVC)		
Cable	High-end type	φ 3.8, 3P, 2m (AWG22, Core diameter: 0.1mm, Number of cores: 25, Insulator diameter: φ 1.25)	φ 4.8, 2P,3P,4P 2m (AWG22, Core diameter: 0.1mm, Number of cores: 30, Insulator diameter: φ 1.25)	
	Standard type	φ 3.8, 3P, 1.5m (AWG22, Core diameter: 0.1mm, Number of cores: 25, Insulator diameter: φ 1.25)	φ 4.8, 2P,3P,4P 1.5m (AWG22, Core diameter: 0.1mm, Number of cores: 30, Insulator diameter: φ 1.25)	
Protection		IP65		

Specifications

Through-bethod type

Model	High-end type	CGY12-T3NA CGY12-T3NB CGY12-T3PA CGY12-T3PB	CGY18-T5NA CGY18-T5NB CGY18-T5NC CGY18-T5PA CGY18-T5PB CGY18-T5PC CGY18-T5KA CGY18-T5KB	CGY18-T10NA CGY18-T10NB CGY18-T10NC CGY18-T10PA CGY18-T10PB CGY18-T10PC CGY18-T10KA CGY18-T10KB	CGY30-T10NA CGY30-T10NB CGY30-T10NC CGY30-T10PA CGY30-T10PB CGY30-T10PC CGY30-T10KA CGY30-T10KB	CGY30-T15NA CGY30-T15NB CGY30-T15NC CGY30-T15PA CGY30-T15PB CGY30-T15PC CGY30-T15KA CGY30-T15KB
	Standard type	CGY12E-T3NA CGY12E-T3NB CGY12E-T3PA CGY12E-T3PB	CGY18E-T5NA CGY18E-T5NB CGY18E-T5NC CGY18E-T5PA CGY18E-T5PB CGY18E-T5PC CGY18E-T5KA CGY18E-T5KB	CGY18E-T10NA CGY18E-T10NB CGY18E-T10NC CGY18E-T10PA CGY18E-T10PB CGY18E-T10PC CGY18E-T10KA CGY18E-T10KB	CGY30E-T10NA CGY30E-T10NB CGY30E-T10NC CGY30E-T10PA CGY30E-T10PB CGY30E-T10PC CGY30E-T10KA CGY30E-T10KB	CGY30E-T15NA CGY30E-T15NB CGY30E-T15NC CGY30E-T15PA CGY30E-T15PB CGY30E-T15PC CGY30E-T15KA CGY30E-T15KB
Sensing distance		3m	5m	10m	10m	15m
Hysteresis		3-20%				
Light source		Infrared LED (880nm)				
Consumption current		Max. 40mA				
Power supply (Operating voltage)		10-30VDC / 90-250VAC				
Response time		< 8.2ms				
Residual voltage		DC Max. 1V / AC Max. 10V				
Affection by Temp.		Max. ± 10% for sensing distance at ambient temperature 20°C				
Control output		Max. 200mA				
Insulation resistance		Min. 50MΩ (at 500VDC megger)				
Dielectric strength		1500VAC 50/60Hz for 1minute				
Vibration		1mm amplitude at frequency of 10 to 55Hz(for 1 min.) in each of X, Y, Z directions for 2 hours				
Shock		500m/s <sup>2</sup> (approx. 50G) X, Y, Z directions for 3 times				
Indicator		Operation indicator(red LED)				
Ambient temperature		-15~+55°C (No icing)				
Storage temperature		-15~+55°C (No icing)				
Ambient humidity		35~95%RH (No condensation)				
Protection circuit		Surge protection circuit, Overcurrent protection circuit				
Material		Case/Nut: ABS, Sensing surface: PMMA, Standard cable(Gray): Polyvinyl chloride(PVC), Oil resistant cable(Black): Oil resistant Polyvinyl chloride(PVC)				
Cable	High-end type	φ 3.8, 3P, 2m (AWG22, Core diameter: 0.1mm, Number of cores: 25, Insulator diameter: φ 1.25)	φ 4.8, 2P,3P,4P 2m (AWG22, Core diameter: 0.1mm, Number of cores: 30, Insulator diameter: φ 1.25)			
	Standard type	φ 3.8, 3P, 1.5m (AWG22, Core diameter: 0.1mm, Number of cores: 25, Insulator diameter: φ 1.25)	φ 4.8, 2P,3P,4P 1.5m (AWG22, Core diameter: 0.1mm, Number of cores: 30, Insulator diameter: φ 1.25)			
Protection		IP65				





Appearance and Dimension

CGY18-D



CGY18-R



CGY18-T



CGY30-D



CGY30-R



CGY30-T



Appearance and Dimension

CGY18E-D



CGY18E-R



CGY18E-T



CGY30E-D



CGY30E-R



CGY30E-T





**Features**

- Black mark for standard type
- Dark grey mark for high-end type
  
- Exclusively designed IC for improving anti-jamming capability
- Inside surge protection, reverse polarity protection
- Long use-life cycle and high reliability, easy install, economic price
- Red LED status indication, easy to confirm work situation
- Protection structure IP65(IEC standard)



■ Black



■ Dark grey



**Model Number Structure**

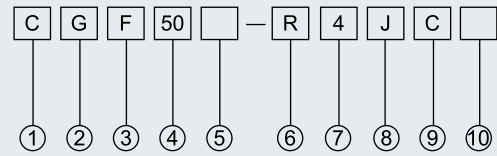

Item	Code	Description
① Company code	C	Company code
② Product name	G	Photoelectric sensor
③ Shape of shell	F	Square
④ Dimension code	50	50=Square 50
⑤ Product type	Without	Without =High-end type (Dark grey shell)
	E	E=Standard type (Black shell)
⑥ Installation form	D	Diffuse-reflective type
	R	Retro-reflective type
	T	Through-bethod type
⑦ Detection distance	4	4=4m
⑧ Output mode	K	AC 2wires
	P	PNP 3wires
	N	NPN 3wires
	J	Relay
⑨ Output state	A	NO
	B	NC
	C	NO+NC
⑩ Connection	Without	Without: Lead wire
	T	Plug-in
	R	Wiring leads Plug-in

**Specifications**

Diffuse-reflective type

Model	High-end type	CGF50-D30JC	CGF70-D50JC	
	Standard type	CGF50E-D30JC	CGF70E-D50JC	
Sensing distance		30cm(adjustable)	50cm(adjustable)	
Hysteresis	3-20%			
Light source	Infrared LED (880nm)			
Consumption current	Max. 25mA			
Power supply (Operating voltage)	24-250VDC/AC(High-end type) 10-30VDC / 90-250VAC(Standard type)			
Response time	< 8.2ms			
Residual voltage	Max. 1V			
Affection by Temp.	Max. ± 10% for sensing distance at ambient temperature 20℃			
Control output	3A			
Insulation resistance	Min. 50MΩ(at 500VDC megger)			
Dielectric strength	1500VAC 50/60Hz for 1minute			
Vibration	1mm amplitude at frequency of 10 to 55Hz(for 1 min.) in each of X, Y, Z directions for 2 hours			
Shock	500m/s <sup>2</sup> (approx. 50G) X, Y, Z directions for 3 times			
Indicator	Operation indicator(red LED)			
Ambient temperature	-15~+55℃ (No icing)			
Storage temperature	-15~+55℃ (No icing)			
Ambient humidity	35~95%RH (No condensation)			
Protection circuit	Surge protection circuit			
Material	Case: ABS, Sensing surface: PMMA, Standard cable(Gray): Polyvinyl chloride(PVC), Oil resistant cable(Black): Oil resistant Polyvinyl chloride(PVC)			
Cable	High-end type	φ 3.8, 3P,4P 2m (AWG22, Core diameter: 0.1mm, Number of cores:25, Insulator diameter: φ 1.25)	φ 6, 5P, 2m (AWG22, Core diameter: 0.1mm, Number of cores: 22, Insulator diameter: φ 1.25)	/
		φ 3.8, 3P,4P 1.5m (AWG22, Core diameter: 0.1mm, Number of cores:25, Insulator diameter: φ 1.25)	φ 6, 5P, 1.5m (AWG22, Core diameter: 0.1mm, Number of cores: 22, Insulator diameter: φ 1.25)	/
Cable	Standard type	φ 3.8, 3P,4P 1.5m (AWG22, Core diameter: 0.1mm, Number of cores:25, Insulator diameter: φ 1.25)	φ 6, 5P, 1.5m (AWG22, Core diameter: 0.1mm, Number of cores: 22, Insulator diameter: φ 1.25)	/
		φ 3.8, 3P,4P 2m (AWG22, Core diameter: 0.1mm, Number of cores:25, Insulator diameter: φ 1.25)	φ 6, 5P, 2m (AWG22, Core diameter: 0.1mm, Number of cores: 22, Insulator diameter: φ 1.25)	/
Protection	IP65			



Specifications

Diffuse-reflective type

Model	High-end type	CGF30-D30NA CGF30-D30NB CGF30-D30NC CGF30-D30PA CGF30-D30PB CGF30-D30PC	CGF50-D30NA CGF50-D30NB CGF50-D30NC CGF50-D30PA CGF50-D30PB CGF50-D30PC	CGF70-D50NA CGF70-D50NB CGF70-D50NC CGF70-D50PA CGF70-D50PB CGF70-D50PC
	Standard type	CGF30E-D30NA CGF30E-D30NB CGF30E-D30NC CGF30E-D30PA CGF30E-D30PB CGF30E-D30PC	CGF50E-D30NA CGF50E-D30NB CGF50E-D30NC CGF50E-D30PA CGF50E-D30PB CGF50E-D30PC	CGF70E-D50NA CGF70E-D50NB CGF70E-D50NC CGF70E-D50PA CGF70E-D50PB CGF70E-D50PC
Sensing distance	30cm(Adjustable)		50cm(Adjustable)	
Hysteresis	3-20%			
Light source	Infrared LED (880nm)			
Consumption current	Max. 25mA			
Power supply (Operating voltage)	10-30VDC			
Response time	< 8.2ms			
Residual voltage	Max.1V			
Affection by Temp.	Max. ± 10% for sensing distance at ambient temperature 20 °C			
Control output	Max. 200mA			
Insulation resistance	Min. 50MΩ(at 500VDC megger)			
Dielectric strength	1500VAC 50/60Hz for 1minute			
Vibration	1mm amplitude at frequency of 10 to 55Hz(for 1 min.) in each of X, Y, Z directions for 2 hours			
Shock	500m/s <sup>2</sup> (approx. 50G) X, Y, Z directions for 3 times			
Indicator	Operation indicator(red LED)			
Ambient temperature	-15~+55 °C (No icing)			
Storage temperature	-15~+55 °C (No icing)			
Ambient humidity	35~95%RH (No condensation)			
Protection circuit	Surge protection circuit, Overcurrent protection circuit			
Material	Case: ABS, Sensing surface: PMMA, Standard cable(Gray): Polyvinyl chloride(PVC), Oil resistant cable(Black): Oil resistant Polyvinyl chloride(PVC)			
Cable	High-end type	φ 3.8, 3P,4P 2m (AWG22, Core diameter: 0.1mm, Number of cores:25, Insulator diameter: φ 1.25)	φ 6, 3P,4P, 2m (AWG22, Core diameter: 0.1mm, Number of cores: 22, Insulator diameter: φ 1.25)	/
	Standard type	φ 3.8, 3P,4P 1.5m (AWG22, Core diameter: 0.1mm, Number of cores:25, Insulator diameter: φ 1.25)	φ 6, 3P,4P, 1.5m (AWG22, Core diameter: 0.1mm, Number of cores: 22, Insulator diameter: φ 1.25)	/
Protection	IP65			

Specifications

Retro-reflective type

Model	High-end type	CGF50-R4JC	CGF70-R5JC
	Standard type	CGF50E-R4JC	CGF70E-R5JC
Sensing distance		4m	5m
Hysteresis	3-20%		
Light source	Infrared LED (880nm)		
Consumption current	Max. 25mA		
Power supply (Operating voltage)	24-250VDC/AC(High-end type) 10-30VDC / 90-250VAC(Standard type)		
Response time	< 8.2ms		
Reflector	TD08		
Residual voltage	Max. 1V		
Affection by Temp.	Max. ± 10% for sensing distance at ambient temperature 20 °C		
Control output	3A		
Insulation resistance	Min. 50MΩ(at 500VDC megger)		
Dielectric strength	1500VAC 50/60Hz for 1minute		
Vibration	1mm amplitude at frequency of 10 to 55Hz(for 1 min.) in each of X, Y, Z directions for 2 hours		
Shock	500m/s <sup>2</sup> (approx. 50G) X, Y, Z directions for 3 times		
Indicator	Operation indicator(red LED)		
Ambient temperature	-15~+55 °C (No icing)		
Storage temperature	-15~+55 °C (No icing)		
Ambient humidity	35~95%RH (No condensation)		
Protection circuit	Surge protection circuit,		
Material	Case: ABS, Sensing surface: PMMA, Standard cable(Gray): Polyvinyl chloride(PVC), Oil resistant cable(Black): Oil resistant Polyvinyl chloride(PVC)		
Cable	High-end type	φ 3.8, 3P,4P 2m (AWG22, Core diameter: 0.1mm, Number of cores:25, Insulator diameter: φ 1.25)	φ 6, 5P, 2m (AWG22, Core diameter: 0.1mm, Number of cores: 22, Insulator diameter: φ 1.25)
	Standard type	φ 3.8, 3P,4P 1.5m (AWG22, Core diameter: 0.1mm, Number of cores:25, Insulator diameter: φ 1.25)	φ 6, 5P, 1.5m (AWG22, Core diameter: 0.1mm, Number of cores: 22, Insulator diameter: φ 1.25)
Protection	IP65		





Specifications

Retro-reflective type

Model	High-end type	CGF30-R1NA CGF30-R1NB CGF30-R1NC CGF30-R1PA CGF30-R1PB CGF30-R1PC	CGF50-R4NA CGF50-R4NB CGF50-R4NC CGF50-R4PA CGF50-R4PB CGF50-R4PC	CGF70-R5NA CGF70-R5NB CGF70-R5NC CGF70-R5PA CGF70-R5PB CGF70-R5PC
	Standard type	CGF30E-R1NA CGF30E-R1NB CGF30E-R1NC CGF30E-R1PA CGF30E-R1PB CGF30E-R1PC	CGF50E-R4NA CGF50E-R4NB CGF50E-R4NC CGF50E-R4PA CGF50E-R4PB CGF50E-R4PC	CGF70E-R5NA CGF70E-R5NB CGF70E-R5NC CGF70E-R5PA CGF70E-R5PB CGF70E-R5PC
Sensing distance		1m	4m	5m
Hysteresis	3-20%			
Light source	Infrared LED (880nm)			
Consumption current	Max. 25mA			
Power supply (Operating voltage)	10-30VDC			
Response time	< 8.2ms			
Reflector	High-end type	TD08		
	Standard type	TD09		TD05
Residual voltage	Max. 1V			
Affection by Temp.	Max. ± 10% for sensing distance at ambient temperature 20°C			
Control output	Max. 200mA			
Insulation resistance	Min. 50MΩ (at 500VDC megger)			
Dielectric strength	1500VAC 50/60Hz for 1minute			
Vibration	1mm amplitude at frequency of 10 to 55Hz(for 1 min.) in each of X, Y, Z directions for 2 hours			
Shock	500m/s <sup>2</sup> (approx. 50G) X, Y, Z directions for 3 times			
Indicator	Operation indicator(red LED)			
Ambient temperature	-15~+55°C (No icing)			
Storage temperature	-15~+55°C (No icing)			
Ambient humidity	35~95%RH (No condensation)			
Protection circuit	Surge protection circuit, Overcurrent protection circuit			
Material	Case: ABS, Sensing surface: PMMA, Standard cable(Gray): Polyvinyl chloride(PVC), Oil resistant cable(Black): Oil resistant Polyvinyl chloride(PVC)			
Cable	High-end type	φ 3.8, 3P,4P 2m	φ 6, 3P,4P, 2m	/
		(AWG22, Core diameter: 0.1mm, Number of cores:25, Insulator diameter: φ 1.25)	(AWG22, Core diameter: 0.1mm, Number of cores: 22, Insulator diameter: φ 1.25)	/
Cable	Standard type	φ 3.8, 3P,4P 1.5m	φ 6, 3P,4P, 1.5m	/
		(AWG22, Core diameter: 0.1mm, Number of cores:25, Insulator diameter: φ 1.25)	(AWG22, Core diameter: 0.1mm, Number of cores: 22, Insulator diameter: φ 1.25)	/
Protection	IP65			

Specifications

Through-bethod type

Model	High-end type		CGF50-T10JC	CGF70-T15JC
	Standard type		CGF50E-T10JC	CGF70E-T15JC
Sensing distance			10m	15m
Hysteresis	3-20%			
Light source	Infrared LED (880nm)			
Consumption current	Max. 50mA			
Power supply (Operating voltage)	24-250VDC/AC(High-end type) 10-30VDC / 90-250VAC(Standard type)			
Response time	< 8.2ms			
Residual voltage	Max. 1V			
Affection by Temp.	Max. ± 10% for sensing distance at ambient temperature 20°C			
Control output	3A			
Insulation resistance	Min. 50MΩ (at 500VDC megger)			
Dielectric strength	1500VAC 50/60Hz for 1minute			
Vibration	1mm amplitude at frequency of 10 to 55Hz(for 1 min.) in each of X, Y, Z directions for 2 hours			
Shock	500m/s <sup>2</sup> (approx. 50G) X, Y, Z directions for 3 times			
Indicator	Operation indicator(red LED)			
Ambient temperature	-15~+55°C (No icing)			
Storage temperature	-15~+55°C (No icing)			
Ambient humidity	35~95%RH (No condensation)			
Protection circuit	Surge protection circuit			
Material	Case: ABS, Sensing surface: PMMA, Standard cable(Gray): Polyvinyl chloride(PVC), Oil resistant cable(Black): Oil resistant Polyvinyl chloride(PVC)			
Cable	High-end type	φ 3.8, 3P,4P 2m	φ 6, 5P, 2m	/
		(AWG22, Core diameter: 0.1mm, Number of cores:25, Insulator diameter: φ 1.25)	(AWG22, Core diameter: 0.1mm, Number of cores: 22, Insulator diameter: φ 1.25)	/
Cable	Standard type	φ 3.8, 3P,4P 1.5m	φ 6, 5P, 1.5m	/
		(AWG22, Core diameter: 0.1mm, Number of cores:25, Insulator diameter: φ 1.25)	(AWG22, Core diameter: 0.1mm, Number of cores: 22, Insulator diameter: φ 1.25)	/
Protection	IP65			



Specifications

Through-bethod type

Model	High-end type	CGF30-T5NA CGF30-T5NB CGF30-T5NC CGF30-T5PA CGF30-T5PB CGF30-T5PC	CGF50-T10NA CGF50-T10NB CGF50-T10NC CGF50-T10PA CGF50-T10PB CGF50-T10PC	CGF70-T15NA CGF70-T15NB CGF70-T15NC CGF70-T15PA CGF70-T15PB CGF70-T15PC
	Standard type	CGF30E-T5NA CGF30E-T5NB CGF30E-T5NC CGF30E-T5PA CGF30E-T5PB CGF30E-T5PC	CGF50E-T10NA CGF50E-T10NB CGF50E-T10NC CGF50E-T10PA CGF50E-T10PB CGF50E-T10PC	CGF70E-T15NA CGF70E-T15NB CGF70E-T15NC CGF70E-T15PA CGF70E-T15PB CGF70E-T15PC
Sensing distance	5m		10m	15m
Hysteresis	3-20%			
Light source	Infrared LED (880nm)			
Consumption current	Max. 40mA			
Power supply (Operating voltage)	10-30VDC			
Response time	< 8.2ms			
Residual voltage	Max. 1V			
Affection by Temp.	Max. ± 10% for sensing distance at ambient temperature 20 °C			
Control output	Max. 200mA			
Insulation resistance	Min. 50MΩ (at 500VDC megger)			
Dielectric strength	1500VAC 50/60Hz for 1minute			
Vibration	1mm amplitude at frequency of 10 to 55Hz(for 1 min.) in each of X, Y, Z directions for 2 hours			
Shock	500m/s <sup>2</sup> (approx. 50G) X, Y, Z directions for 3 times			
Indicator	Operation indicator(red LED)			
Ambient temperature	-15~+55 °C (No icing)			
Storage temperature	-15~+55 °C (No icing)			
Ambient humidity	35~95%RH (No condensation)			
Protection circuit	Surge protection circuit, Overcurrent protection circuit			
Material	Case: ABS, Sensing surface: PMMA, Standard cable(Gray): Polyvinyl chloride(PVC), Oil resistant cable(Black): Oil resistant Polyvinyl chloride(PVC)			
Cable	High-end type	φ 3.8, 3P,4P 2m (AWG22, Core diameter: 0.1mm, Number of cores:25, Insulator diameter: φ 1.25)	φ 6, 2P,3P,4P, 2m (AWG22, Core diameter: 0.1mm, Number of cores:22, Insulator diameter: φ 1.25)	/
	Standard type	φ 3.8, 3P,4P 1.5m (AWG22, Core diameter: 0.1mm, Number of cores:25, Insulator diameter: φ 1.25)	φ 6, 2P,3P,4P, 1.5m (AWG22, Core diameter: 0.1mm, Number of cores:22, Insulator diameter: φ 1.25)	/
Protection	IP65			

Appearance and Dimension

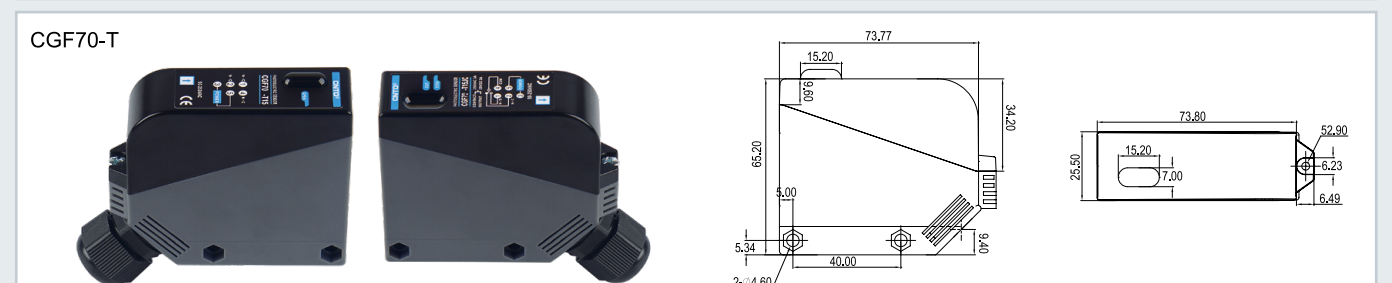
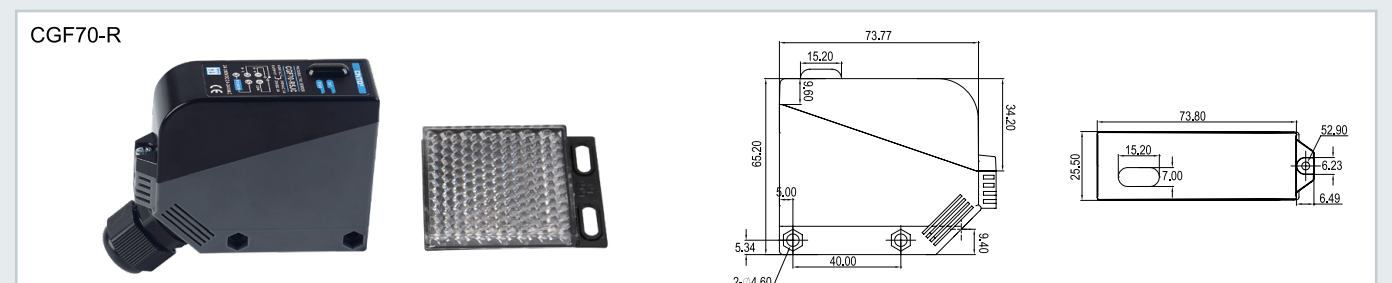
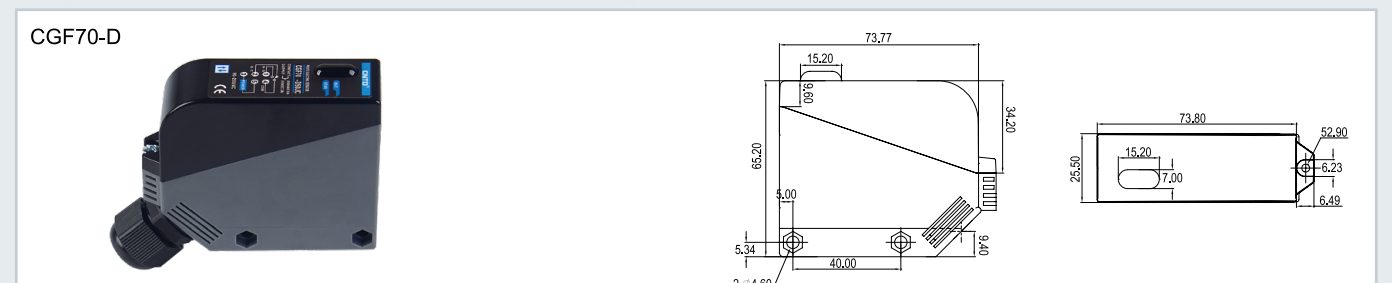
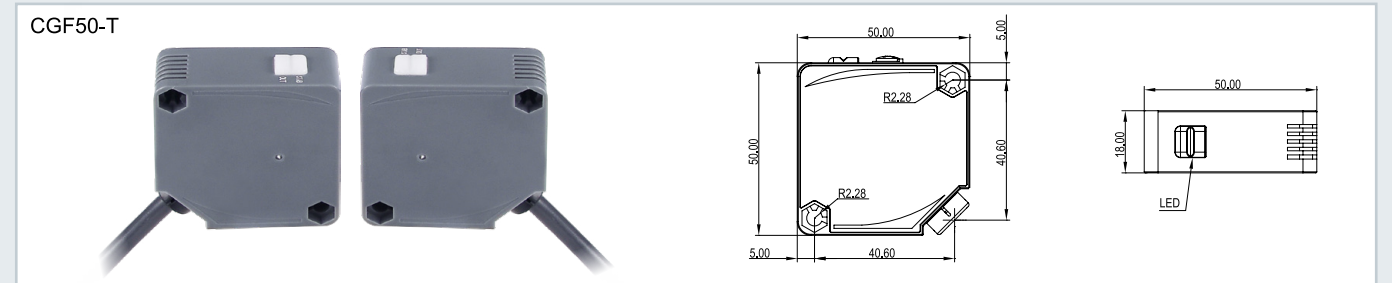
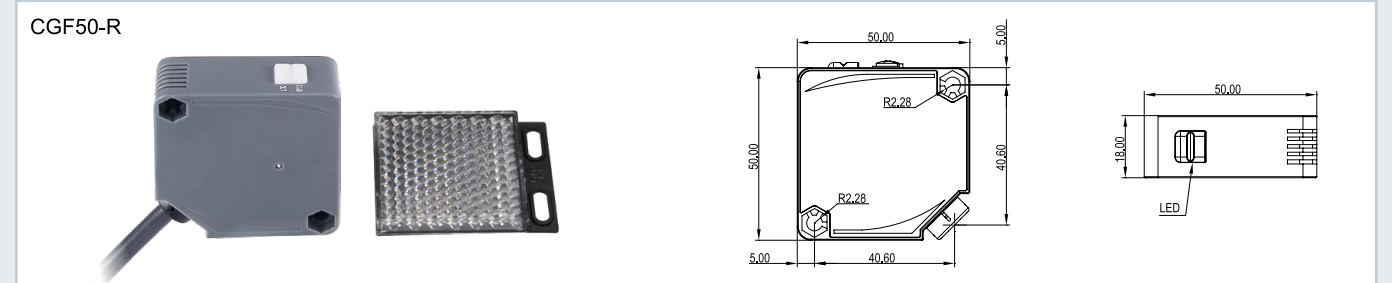
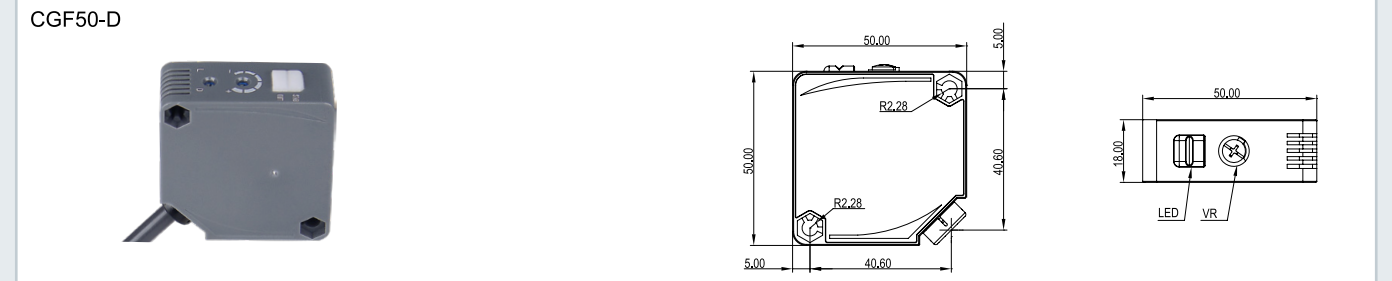



Appearance and Dimension

**CGF30E-D**

**CGF30E-R**

**CGF30E-T**

**CGF50E-D**

**CGF50E-R**

**CGF50E-T**

Appearance and Dimension

**CGF70E-D**

**CGF70E-R**

**CGF70E-T**





Features

- Black mark for standard type
- Dark grey mark for high-end type
  
- Exclusively designed IC for improving anti-jamming capability
- Inside surge protection, reverse polarity protection
- Long use-life cycle and high reliability, easy install, economic price
- Red LED status indication, easy to confirm work situation
- Protection structure IP65(IEC standard)



■ Black

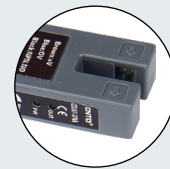

■ Dark grey

Model Number Structure

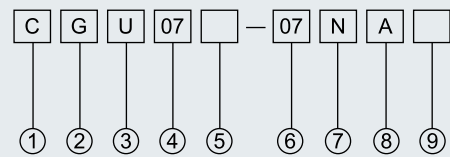

Item	Code	Description
① Company code	C	Company code
② Product name	G	Photoelectric sensor
③ Shape of shell	U	U type
④ Dimension code	07	7mm Groove width 7mm
⑤ Product type	Without	Without =High-end type (Dark grey shell)
	E	E = Standard type (Black shell)
⑥ Detection distance	07	7=7mm
⑦ Output mode	K	AC 2wires
	P	PNP 3wires
	N	NPN 3wires
	J	Relay
⑧ Output state	A	NO
	B	NC
	C	NO+NC
⑨ Connection	Without	Without: Lead wire
	T	Plug-in
	R	Wiring leads Plug-in

Specifications

Model	High-end type	CGU07-07NA CGU07-07NB CGU07-07NC CGU07-07PA CGU07-07PB CGU07-07PC	CGU10-10NA CGU10-10NB CGU10-10PA CGU10-10PB	CGU30-30NA CGU30-30NB CGU30-30NC CGU30-30PA CGU30-30PB CGU30-30PC	CGU50-50NA CGU50-50NB CGU50-50NC CGU50-50PA CGU50-50PB CGU50-50PC
	Standard type	CGU07E-07NA CGU07E-07NB CGU07E-07NC CGU07E-07PA CGU07E-07PB CGU07E-07PC	CGU10E-10NA CGU10E-10NB CGU10E-10PA CGU10E-10PB	CGU30E-30NA CGU30E-30NB CGU30E-30NC CGU30E-30PA CGU30E-30PB CGU30E-30PC	CGU50E-50NA CGU50E-50NB CGU50E-50NC CGU50E-50PA CGU50E-50PB CGU50E-50PC
Sensing distance	7mm	10mm	30mm	50mm	
Light source	Infrared LED (Modulation)				
Consumption current	Max. 15mA				
Power supply (Operating voltage)	10-30VDC				
Response time	< 1ms				
Residual voltage	Max. 1V				
Affection by Temp.	Max. ± 10% for sensing distance at ambient temperature 20℃				
Control output	Max. 200mA				
Insulation resistance	Min. 50MΩ (at 500VDC megger)				
Dielectric strength	1500VAC 50/60Hz for 1minute				
Vibration	1mm amplitude at frequency of 10 to 55Hz(for 1 min.) in each of X, Y, Z directions for 2 hours				
Shock	500m/s <sup>2</sup> (approx. 50G) X, Y, Z directions for 3 times				
Indicator	Operation indicator(red LED)				
Ambient temperature	-15~+55℃ (No icing)				
Storage temperature	-15~+55℃ (No icing)				
Ambient humidity	35~95%RH (No condensation)				
Protection circuit	Surge protection circuit, Overcurrent protection circuit				
Material	Case: ABS, Sensing surface: PMMA, Standard cable(Gray): Polyvinyl chloride(PVC), Oil resistant cable(Black): Oil resistant Polyvinyl chloride(PVC)				
Cable	High-end type	φ 4.8, 3P,4P 2m (AWG22, Core diameter: 0.1mm, Number of cores:30, Insulator diameter: φ 1.25	φ 3.8, 3P, 2m (AWG22, Core diameter: 0.1mm, Number of cores:25, Insulator diameter: φ 1.25	φ 4.8, 3P,4P 2m (AWG22, Core diameter: 0.1mm, Number of cores:30, Insulator diameter: φ 1.25	
		φ 4.8, 3P,4P 1.5m (AWG22, Core diameter: 0.1mm, Number of cores:30, Insulator diameter: φ 1.25	φ 3.8, 3P, 1.5m (AWG22, Core diameter: 0.1mm, Number of cores:25, Insulator diameter: φ 1.25	φ 4.8, 3P,4P 1.5m (AWG22, Core diameter: 0.1mm, Number of cores:30, Insulator diameter: φ 1.25	
Standard type					
Protection	IP65				



Appearance and Dimension

CGU07-07

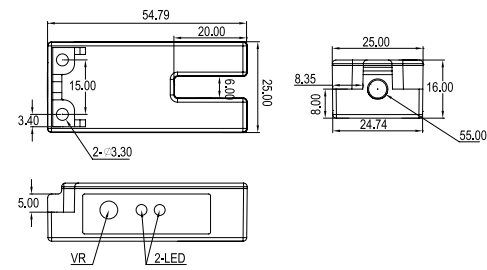

Appearance and Dimension

CGU07E-07

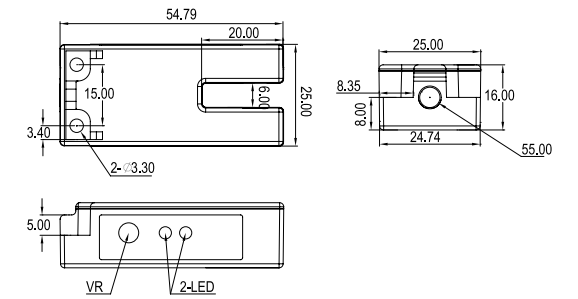

CGU10-10

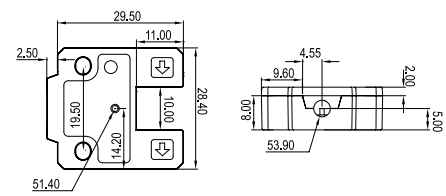

CGU10E-10

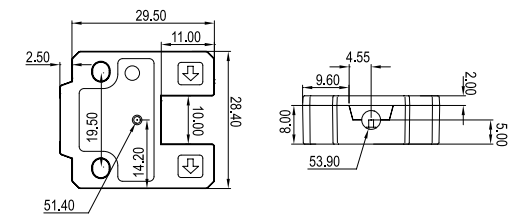
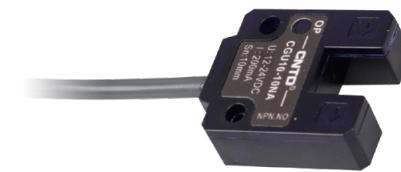

CGU30-30

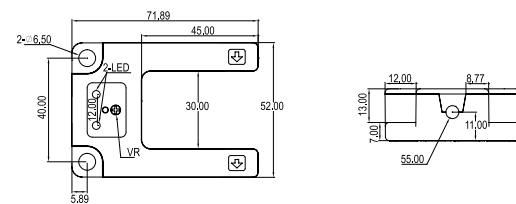

CGU30E-30

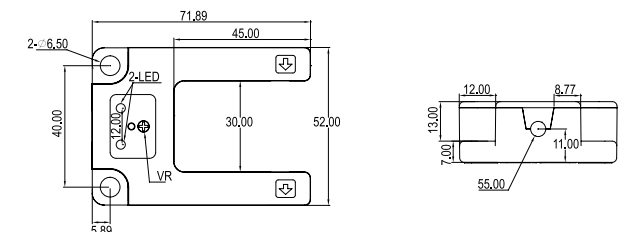

CGU50-50

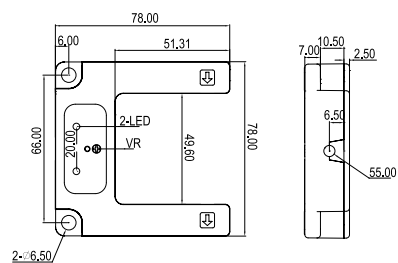

CGU50E-50

