

Manual of Immersion-energy Dry Cooler

Introduction | Structure | Installation | Maintenance



Feature:

1. Refrigerants include but are not limited to chilled water, brine, BC-888, propylene glycol, ethylene glycol.
2. Copper tube aluminum fin or copper tube copper fin, casing is stainless steel and galvanized steel coating.
3. The max refrigerant volume is 150 m³/h.
4. **Especially recommended for Bitcoin Mining cooling.**

www.immersion-energy.com 

Catalog

1	Equipment Introduction	1
1.1	Product model and name	1
1.2	Scope of application	1
1.3	Applicable environment	1
1.4	Standards	1
1.5	Technical Data	1
2	Structure	2
2.1	Schematic Diagram	2
2.2	Function Details	2
3	Installation.....	2
3.1	Lifting.....	2
3.2	Fork lifting.....	2
3.3	Installation	3
3.4	Site assessment	3
3.5	Wiring.....	4
3.6	Electrical Installation.....	5
4	Equipment commissioning.....	5
4.1	Power on check	5
4.2	Power supply check.....	5
4.3	Trial Operation	5
5	Maintenance	6
5.1	Maintenance Schedule.....	6
5.2	Maintenance Norm	6
6	Common fault and treatment	7
7	Others.....	7
7.1	Unpacking note.....	7
7.2	Transportation storage	7

1 Equipment Introduction

1.1 Product model and name

Product: Dry Cooler

Model Number: SHSL-D1-502-12X630F2

1.2 Scope of application

Dry Coolers are widely used in refrigeration, air-conditioning, crypto mining cooling, food processing, heating plants and power plants.

1.3 Applicable environment

A. Dry Cooler series: D1 and D2 series

B. Environment temperature: 0°C

C. Air does not contain chemical substances, corrosive gasses and dust-free

D. Please specify requirements for explosion-proof upon order

E. Design conditions: refrigerant. Medium: water

F. Design pressure 2.0MP. Test pressure 2.5MPa

G. Working conditions

Environment	Specifications
Ambient Temperature 35°C Inlet Temperature 45°C Outlet Temperature 40°C	D2 Series

1.4 Standards

This product implements the standard: JB/T7659.5-1995

1.5 Technical Data

Model: SHSL-D1-502-12X630F

A. Capacity: 493kW

B. Surface: 2315m²

C. Medium: Glycol concentration 20%

D. Airflow volume: 197326m³/h

E. Air outlet Static Pressure: 0 Pa

F. Design Pressure: 2.0MPa

G. Test Pressure: 2.5MPa

H. Power Supply: 3Ph/400V/50Hz

I. Total Motor Power: 22 kW

J. Total Current: 61.2A

K. Dry Weight: 1584 kg

2 Structure

2.1 Schematic Diagram

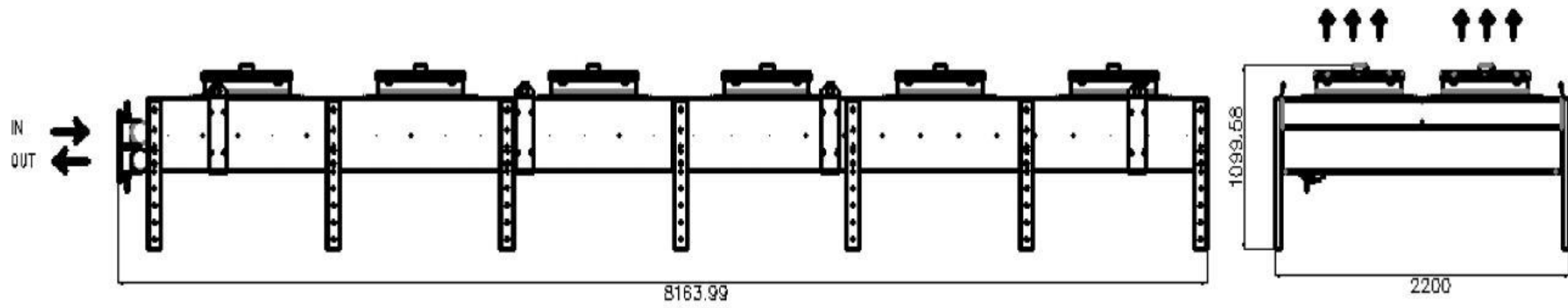

Model of SHSL-D1-502-12X630F2

2.2 Function Details

Sign	Name	Function
A	Stand	Fix equipment
B	Metal Sheet Casing	Galvanized Steel Coated Casing
C	Cooling Coil	Aluminum Fin and Copper Tube
D	Fan	Low Energy consumption fan to maximize air flow and low noise

3 Installation

3.1 Lifting

Lifting position as the picture

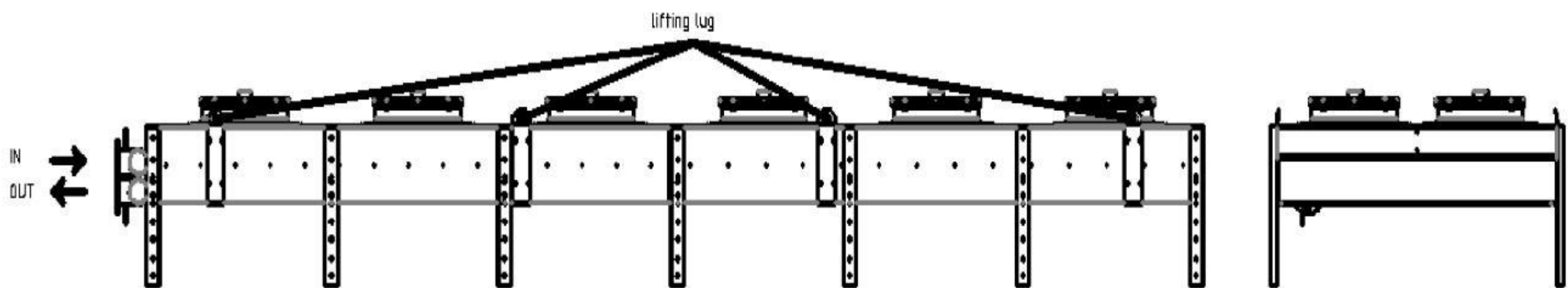

3.2 Fork lifting

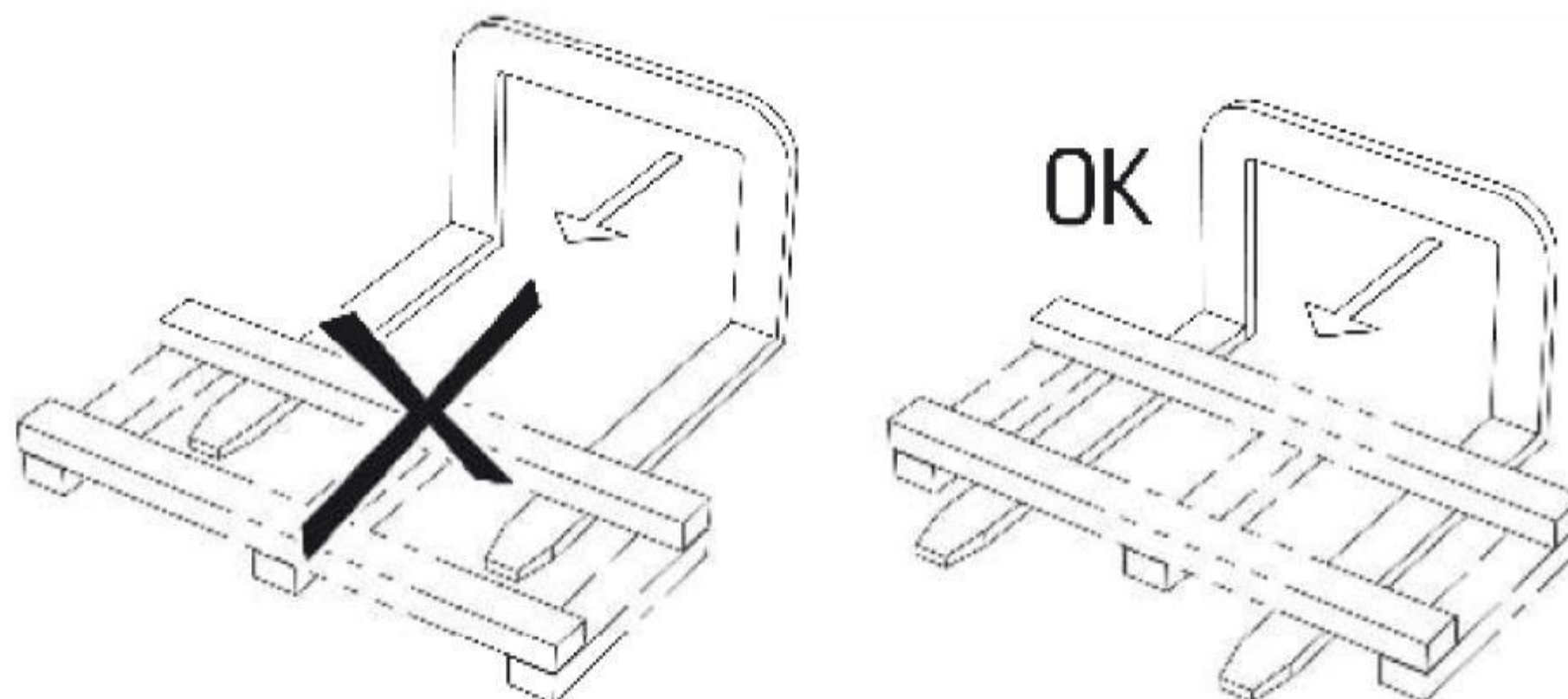

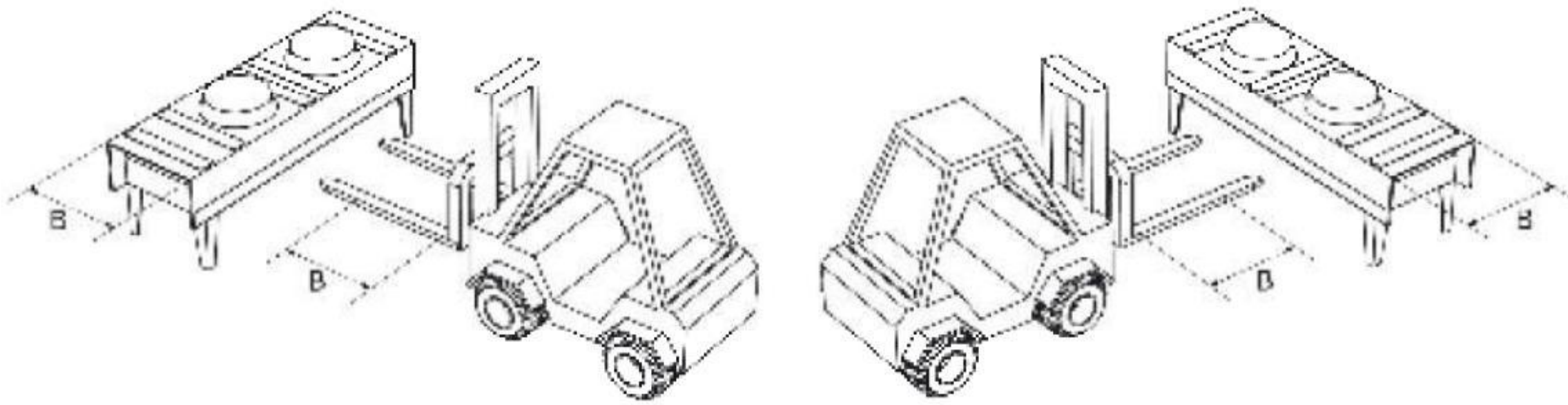

Warning: Forklift arm to be longer than product width

3.3 Installation

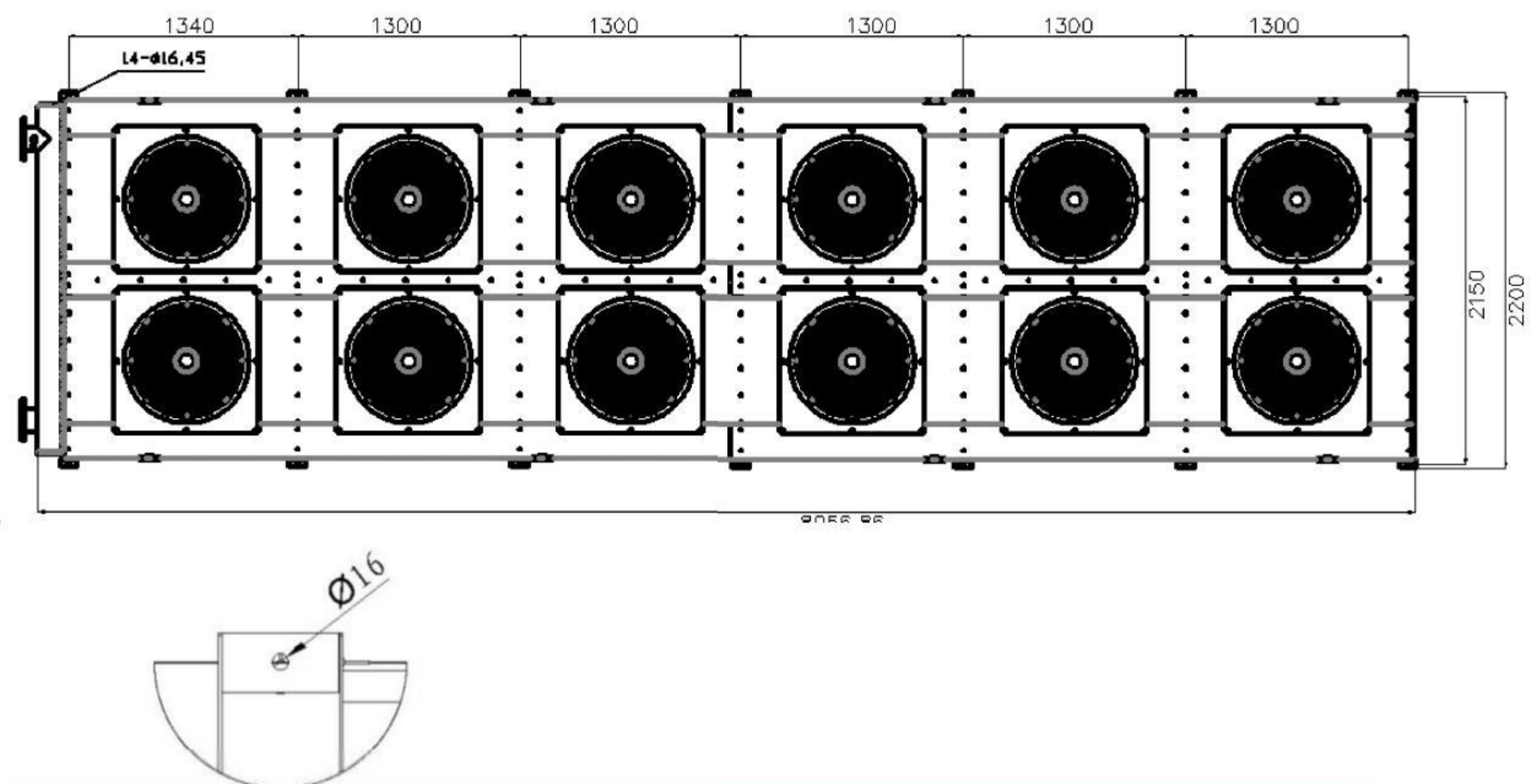

 Warning

Dry coolers are pressure tested and filled with nitrogen prior to shipment
(Excepting Flange Connection)

3.4 Site assessment

Selected installation site must meet the following requirements:

- Level Ground
- Ground or Floor strength able to support the weight of equipment
- No obstructions at air outlet
- Upon confirming above conditions, take the following installation steps:

Forklift or lifting product out of wooden pallets, loosen transport screw at stand and tighten after raising the screws to same horizontal plane as product. After moving product to the predetermined location, bolt tightly with large washer and spring washer.

 Warning

- ✓ Minimize bias and ensure the level of the product during installation.
- ✓ Ensure tubes level and no loosen parts in dry cooler
- ✓ During installation, avoid weight of pipeline on the dry coolers.

3.5 Wiring

Power requirements:

- Axial Fan power wiring: Axial fans are often using one phase or 3 phase motor. The 3 phase motor has two configuration, Y-shape and Δ Shape
- Fan motor should have reliable power supply equipped with over voltage, under voltage and over current protection. Each fan is equipped with current protection settings.

Internal thermal protection devise should be connected to the control lines to prevent damage to the motor due to over voltage, under voltage, lack of phase, contact failure. Motor wiring shall be installed according to the requirements when using two-speed motor.

 Warning

- ✓ Motor overcurrent protection and built in thermal protection settings must be connected
- ✓ Electrical connections must be completed by qualified professionals
- ✓ Ensure wiring are correct and accurate to prevent motor failure

3.6 Electrical Installation

 Warning	
<ul style="list-style-type: none">✓ Equipment installation must be done by qualified personnel✓ Ensure all electrical circuits are installed in accordance GB 8877-88(household appliances installation, use, maintenance and safety requirements) or any other local regulations✓ All electrical terminal lines at the end of the outlet end (fan terminals connection in electrical box for low temperature and medium temperature models)✓ Equipment shall be safely grounded with resistance less than 2Ω✓ Ensure all fan connecting cables are according to required standards of fan manufacturers.	

4 Equipment commissioning

4.1 Power on check

Check to ensure all requirements above are met. All requirements are to be met before trial run. Ensure all accessories are installed securely before powering on.

4.2 Power supply check

Ensure voltage and power supply matches name plate by measuring equipment and is safely grounded with less than 2ohm before power up.

4.3 Trial Operation

Ensure each fan is tighten and is not obstructed prior to commissioning. Rotation of the motor must be accordance with the factory specification. Ensure no jamming and free rotation to fan and motor.

 Reminder	
<ul style="list-style-type: none">✓ Please check with qualified personnel if operations are not successful.	

 Danger	
<ul style="list-style-type: none">✓ High voltage is present during equipment operations.✓ Do not disassemble any components without disconnecting main power	

5 Maintenance

Maintenance of equipment is required to ensure long term stable operations with high efficiency.

5.1 Maintenance Schedule

Schedule	Items
Daily	Keep device surface clean Check for loose equipment, abnormal sound from the motor and fan working smoothly
Monthly	Ensure air inlet are not blocked Clean any dirt on finned tube

5.2 Maintenance Norm

 Mandate
✓ Operators must wear goggles, gloves, helmets and protective clothing to prevent skin or personal injury due to alkaline liquid

5.2.1 Motor maintenance

Fan: Operations should be immediately stopped if fan produces grazing noise. Check fan motor, fan blade, wire insulation and replace or repair accordingly Operating with faulty fan may cause damage to the equipment or personal and property.

Replacement of the fan and motor should be done by qualified personnel. Power supply must be disconnected before repair. Commissioning check the direction of airflow and other functions are required after every repair or replacement. Monitor fan current during daily operations.

Immediately cut off power supply, check and troubleshoot if fan current is abnormal. Do not restart the fan and motor until troubleshooting is completed.

Do not operate in case of motor protection circuit failure.

5.2.2 Spare parts catalog and critical parts:

Item	Model Specification	Number of units	Spare quantity
Motor	FN063-VDS.6N.V7	12	

6 Common fault and treatment

No.	Observation	Possible cause	Action
1	Fan not turning, noise or vibration when started	<ul style="list-style-type: none"> ◆ Lack of phase ◆ Fan impeller blocked 	<ul style="list-style-type: none"> ◆ Eliminate blockage
2	Overheating	<ul style="list-style-type: none"> ◆ Air inlet blocked or obstructed by foreign objects ◆ Impeller severely deformed or damaged ◆ Wrong power supply voltage or frequency ◆ Lack of phase, stator and rotor friction 	<ul style="list-style-type: none"> ◆ Remove foreign objects ◆ Replace impeller ◆ Replace motor to match voltage and frequency ◆ Replace fuse and faulty motor components
3	Current too high	<ul style="list-style-type: none"> ◆ Bearings worn ◆ Impeller and duct friction ◆ Impeller blocked, or out of phase ◆ Other obstacles 	<ul style="list-style-type: none"> ◆ Replace bearings ◆ Adjust the gap between impeller and ducting ◆ Repair circuits ◆ Defrosting
4	Excessive noise or vibration	<ul style="list-style-type: none"> ◆ Impeller damaged ◆ Loose stand ◆ Grill damaged ◆ Airflow obstruction 	<ul style="list-style-type: none"> ◆ Replace impeller ◆ Tighten loose parts ◆ Repair and replace grill ◆ Defrost
5	Leakage, low insulation resistance	<ul style="list-style-type: none"> ◆ Motor storage influent ◆ Moisture 	<ul style="list-style-type: none"> ◆ Dry motor before use

7 Others

7.1 Unpacking note

Carefully unpack equipment, check and ensure no surface damages, bumps and other defects, check against packing list to ensure parts are complete with acceptance certificate and instructions.

7.2 Transportation storage

Equipment should be stored in a dry, airy environment. Avoid high temperature, moisture, acidic or corrosive gases.