

## System analysis

- Sliding roller system
- Hanging sliding roller accessory kit

Perfect A01-G Hanging sliding roller Medium damping for Single door set(High equipment)	Inner Packing Specification	Outer Packing Specification	SAP Code
	1 set/box	20 boxes/case	CA420001-002

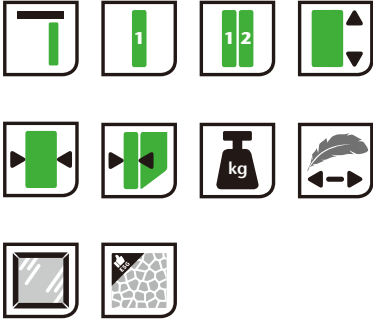

Single door width	≥600mm
Single door thickness	40 or 45mm
Suitable for Glass Thickness	8~11mm
Single door load bearing	≤80kg

### Order instructions

- Please order the profiles and tracks separately
- OVERLAP SLIDING 2 DOORS: Please order 2 sets of Perfect A01-G Hanging sliding roller Medium damping for Single door set(High equipment)

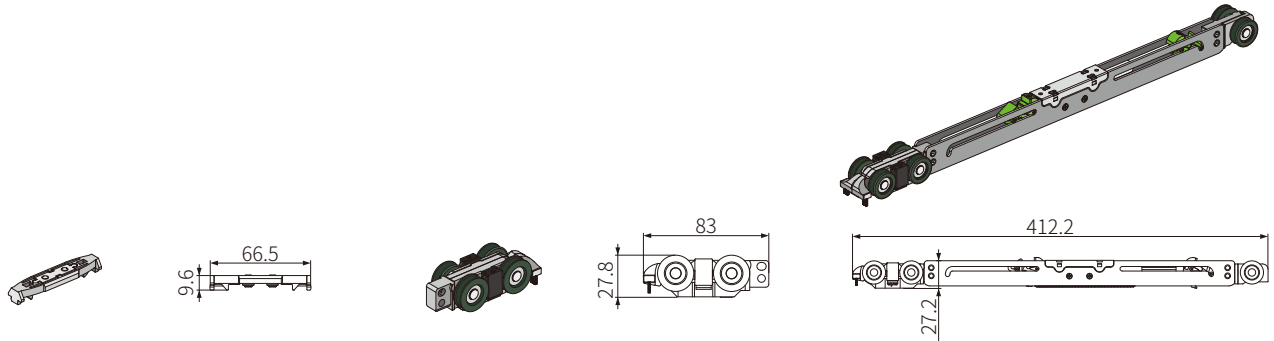

Product name	Quantity	SAP Code	Product name	Quantity	SAP Code	Product name	Quantity	SAP Code
Stopper	x2	CA991385-001	Single hanging sliding roller	x1	CA991383-001	Two-way damping hanging sliding roller	x1	CA991384-001

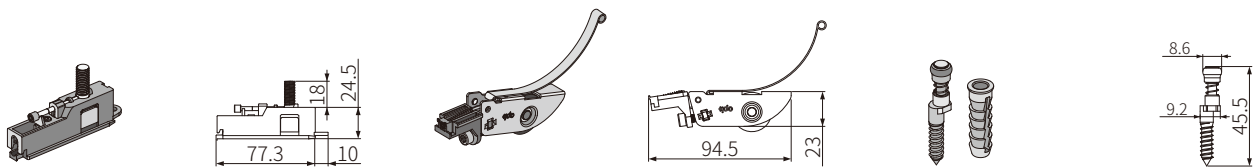

Product name	Quantity	SAP Code	Product name	Quantity	SAP Code	Product name	Quantity	SAP Code
Perfect A01-Hanging Box	x2	CA991441-001	Anti-swing wheel	x2	CA991387-001	the floor guide wheel	x1	CA991393-001

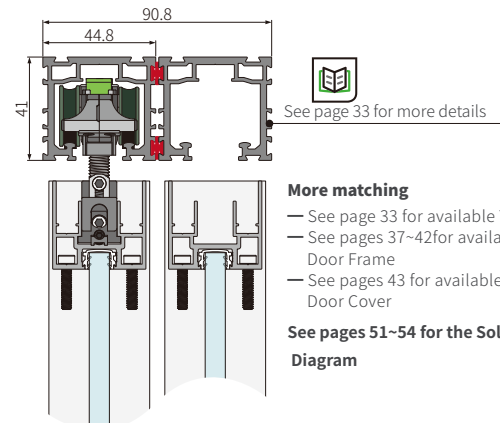

### More matching

- See page 33 for available Tracks
- See pages 37~42for available Door Frame
- See pages 43 for available Door Cover

See pages 51~54 for the Solution Diagram

## System analysis

- Sliding roller system
- Schematic diagram of the Hanging sliding roller Installation

### Split sliding roller Installation

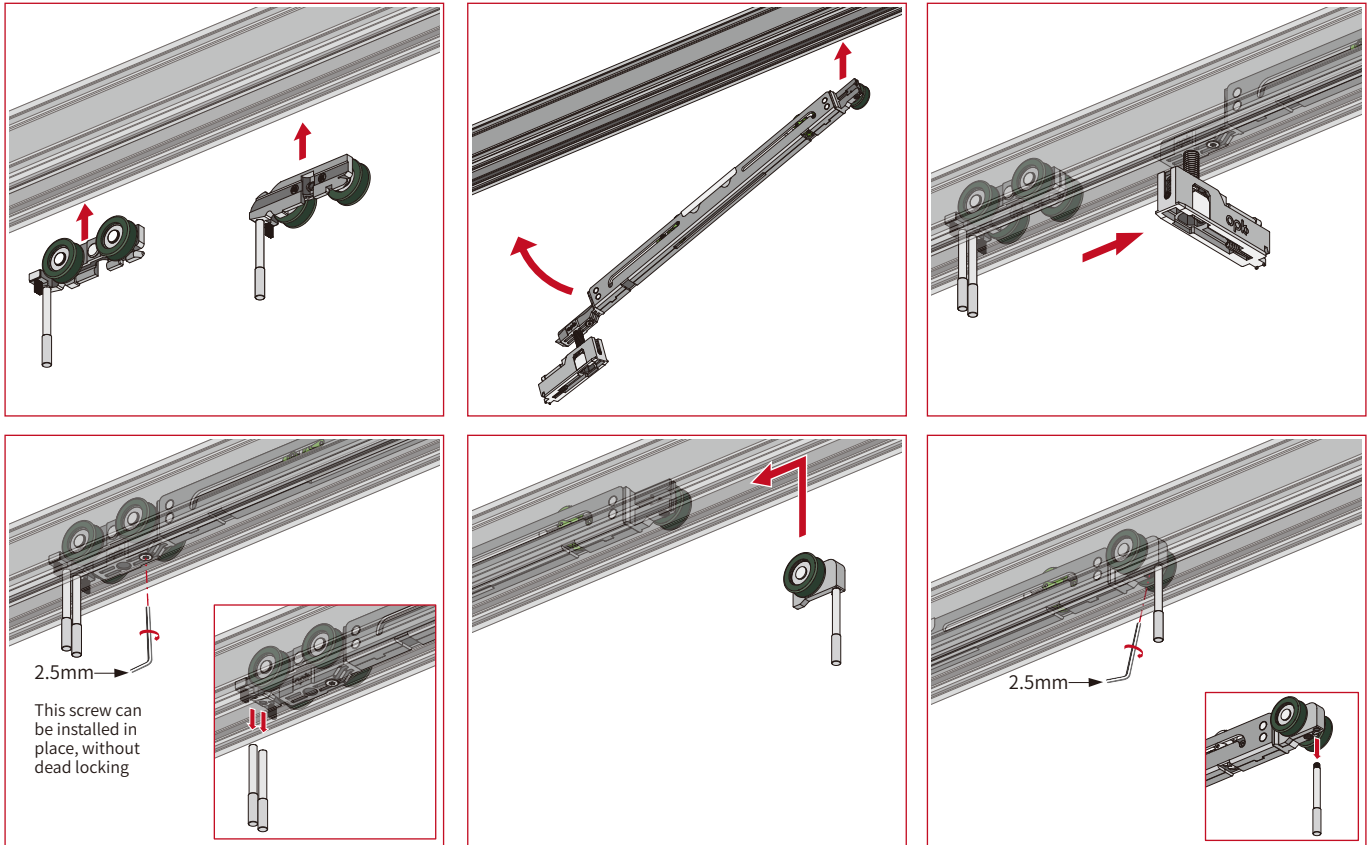

### after-installing damper

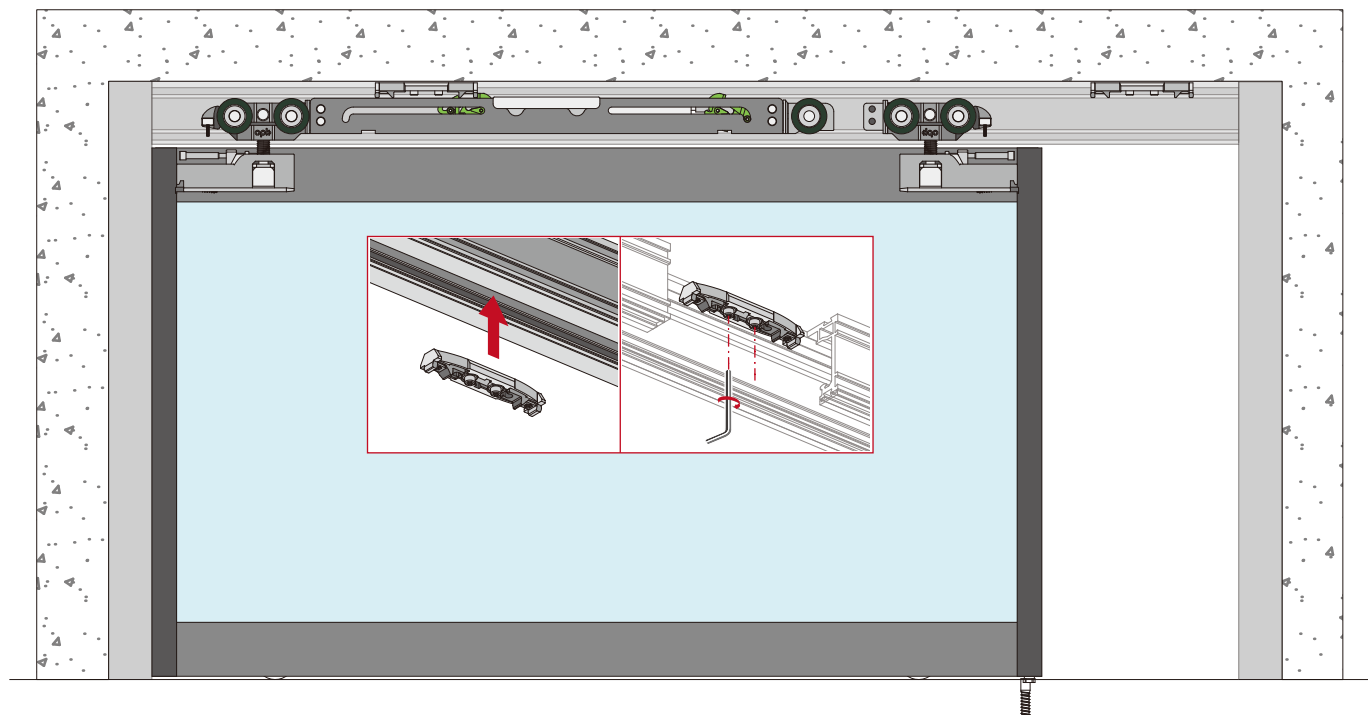

# System analysis

- Sliding roller system
- Hanging sliding roller accessory kit

Perfect A02-G Hanging sliding 3 linkage door for Middle door set (High equipment)40 system	Inner Packing Specification	Outer Packing Specification	SAP code
	1 set/box	20 boxes/case	CA991399-001

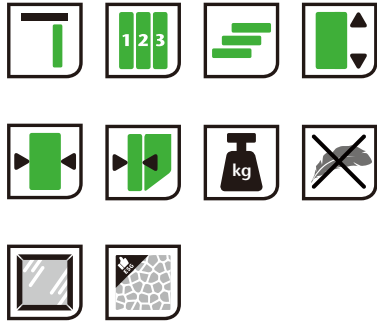

Single door width	Depending on the single-door set
Single door thickness	40mm
Suitable for Glass Thickness	8~11mm
Single door load bearing	≤80kg

### Order Instructions

- Please order the profiles and tracks separately
- 3 LINKAGE DOOR: Please order 2 sets of Perfect A01-G Hanging sliding roller Medium damping for Single door set and 1 sets of Perfect A02-G Hanging sliding 3 linkage door for Middle door set(High equipment)40 system
- Right Angle Linkage Door: Please order 4 sets of Perfect A01-G Hanging sliding roller Medium damping for Single door set and 1 sets of Perfect A02-G Hanging sliding 3 linkage door for Middle door set(High equipment)40 system

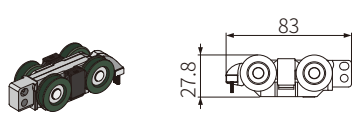

Product name	Quantity	SAP code
Single hanging sliding roller	x2	CA991383-001



Product name	Quantity	SAP code
Perfect A01-Hanging Box	x2	CA991441-001

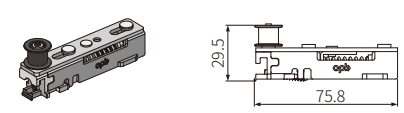

Product name	Quantity	SAP code
Easy Belt Sliding Roller (with elasticity)	x1	CA991582-001



Product name	Quantity	SAP code
Easy Belt Sliding Roller	x1	CA991583-001

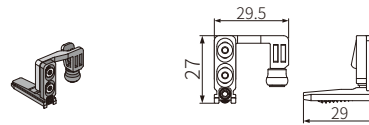

Product name	Quantity	SAP code
Hanging sliding roller belt clamp fixer	x2	CA991390-001

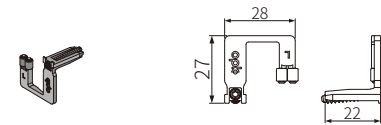

Product name	Quantity	SAP code
Bottom guide wheel (left)	x2	CA991392-001

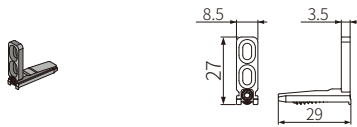

Product name	Quantity	SAP code
Belt clamp limiter	x1	CA991398-001



Product name	Quantity	SAP code
2.5m Synchronous belt	x1	653705

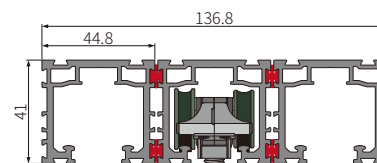

See page 39 for available Tracks

### More matching

- See page 39 for available Tracks
- See pages 43~46 for available Door Frame
- See pages 49 for available Door Cover

### The Solution Diagram

3 Linkage Door: See pages 67~70

Right Angle Linkage Door: See pages 75~78

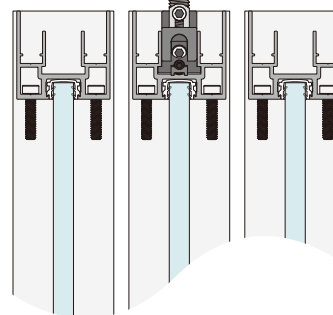

## System analysis

- Sliding roller system
- Schematic diagram of the Hanging sliding roller Installation

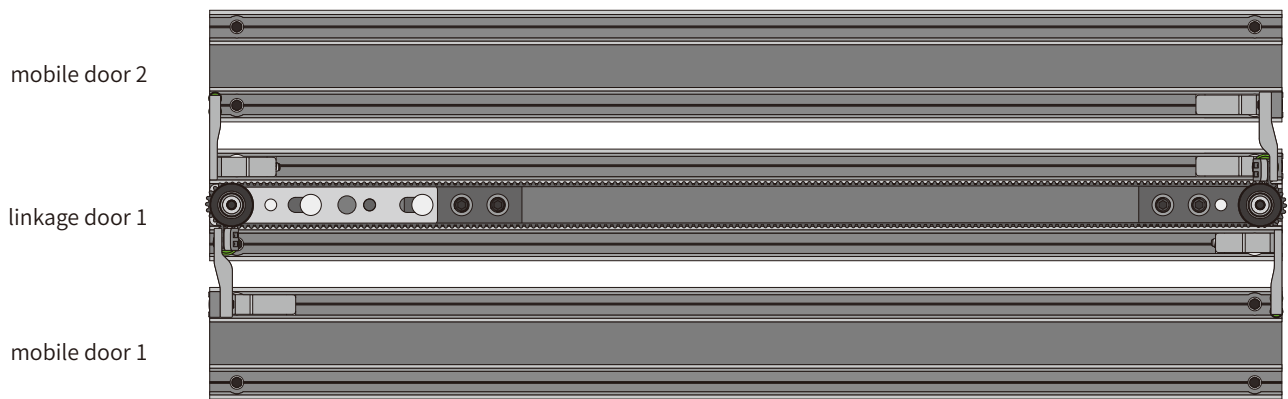

### Bottom view

Connect the door fan

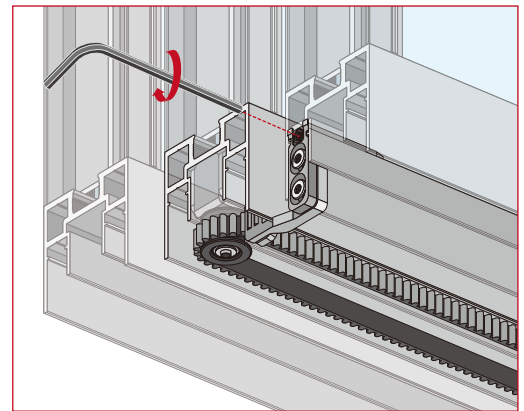
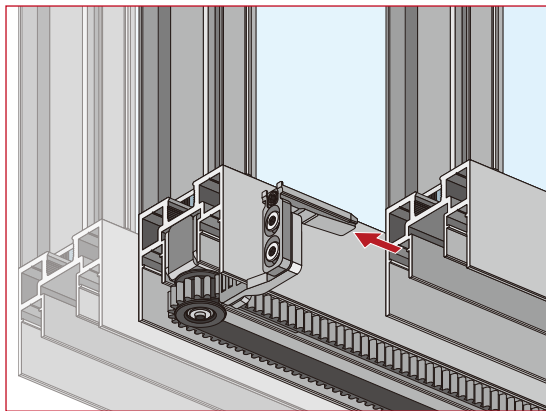

Install the belt clip holder

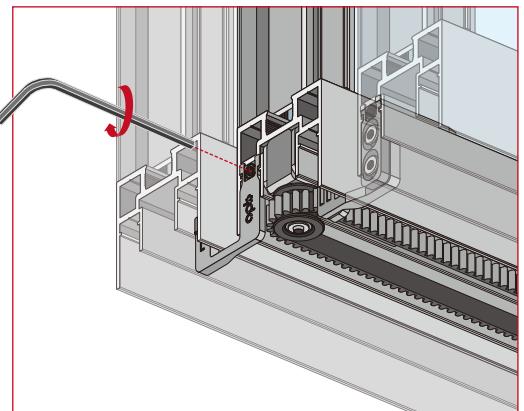
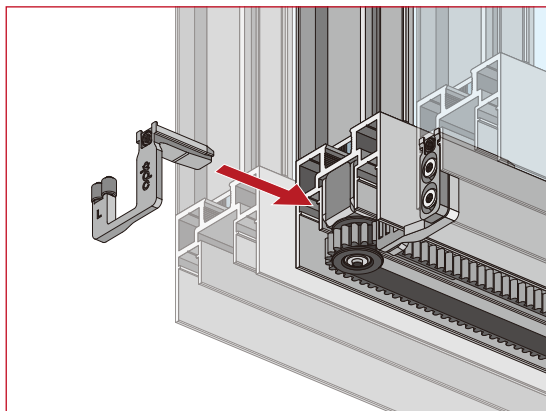

Install the belt clip stopper

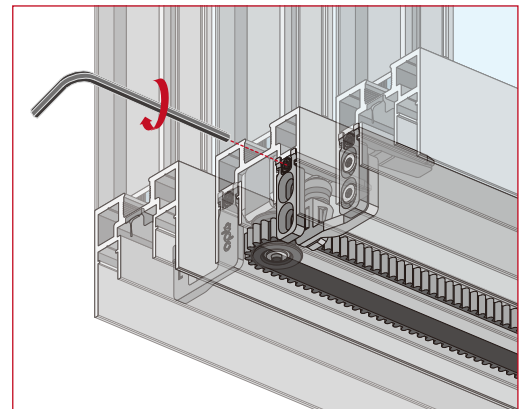
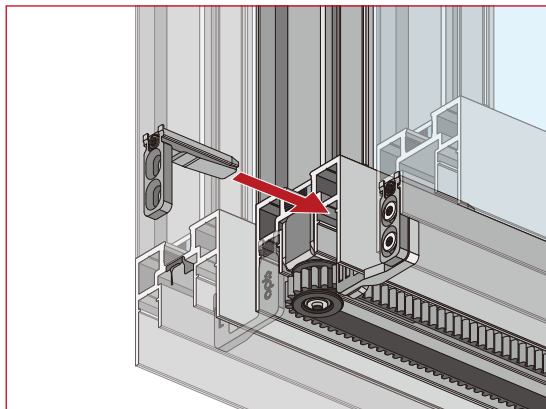

# System analysis

- Door frame system
- 4016 door frame

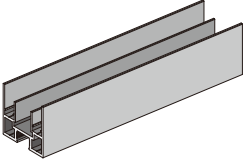

**Technical Overview**

- Meter Weight: 0.76kg/m
- Material: Aluminum Alloy
- Surface Treatment: Enamelled copper/Cypress grey/Titanium void grey
- Length: 6000mm

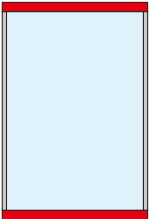

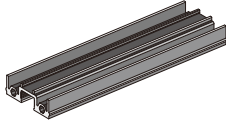

Product name	Model Number
40 door frame top and bottom frame	OPK-A201-40

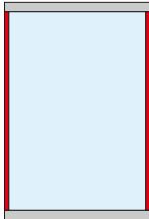

**Technical Overview**

- Meter Weight: 0.45kg/m
- Material: Aluminum Alloy
- Surface Treatment: Enamelled copper/Cypress grey/Titanium void grey
- Length: 6000mm



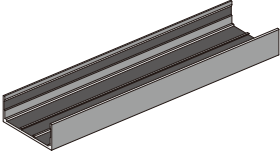

Product name	Model Number
40 door frame mullion (inside)	OPK-A202-40

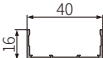
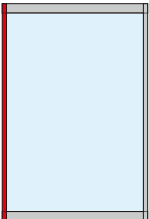

**Technical Overview**

- Meter Weight: 0.27kg/m
- Material: Aluminum Alloy
- Surface Treatment: Enamelled copper/Cypress grey/Titanium void grey
- Length: 6000mm



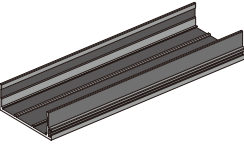

Product name	Model Number
40 door frame mullion (outside)	OPK-A203-40



**Technical Overview**

- Meter Weight: 0.29kg/m
- Material: Aluminum Alloy
- Surface Treatment: Enamelled copper/Cypress grey/Titanium void grey
- Length: 6000mm



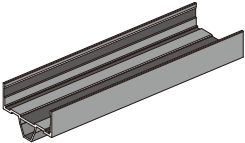

Product name	Model Number
40 door frame mullion (External clasp)	OPK-A204-40

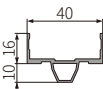
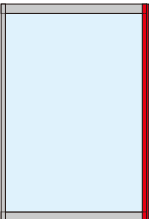

**Technical Overview**

- Meter Weight: 0.35kg/m
- Material: Aluminum Alloy
- Surface Treatment: Enamelled copper/Cypress grey/Titanium void grey
- Length: 6000mm



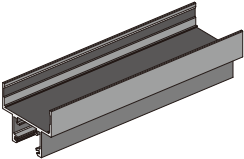

Product name	Model Number
40 synchronized door cover A	OPK-A207-40

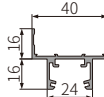
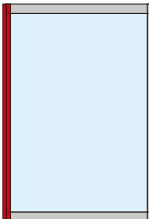

**Technical Overview**

- Meter Weight: 0.48kg/m
- Material: Aluminum Alloy
- Surface Treatment: Enamelled copper/Cypress grey/Titanium void grey
- Length: 6000mm

Product name	Model Number
40 synchronized door cover B	OPK-A208-40

## System analysis

- Door frame system
- 4016 door frame

### Technical Overview

- Meter Weight: 0.41kg/m
- Material: Aluminum Alloy
- Surface Treatment: Enamelled copper/Cypress grey/Titanium void grey
- Length: 6000mm

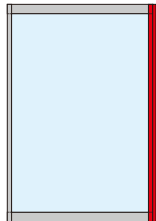
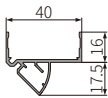
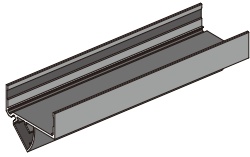

Product name	Model Number
40 right-angle synchronized door cover (arc surface)	OPK-A206-40

### — Schematic diagram of the Door frame system Installation

#### Top and bottom horizontal frame opening dimensions

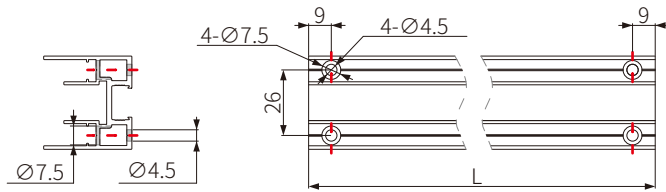

#### Install glass rubber strips

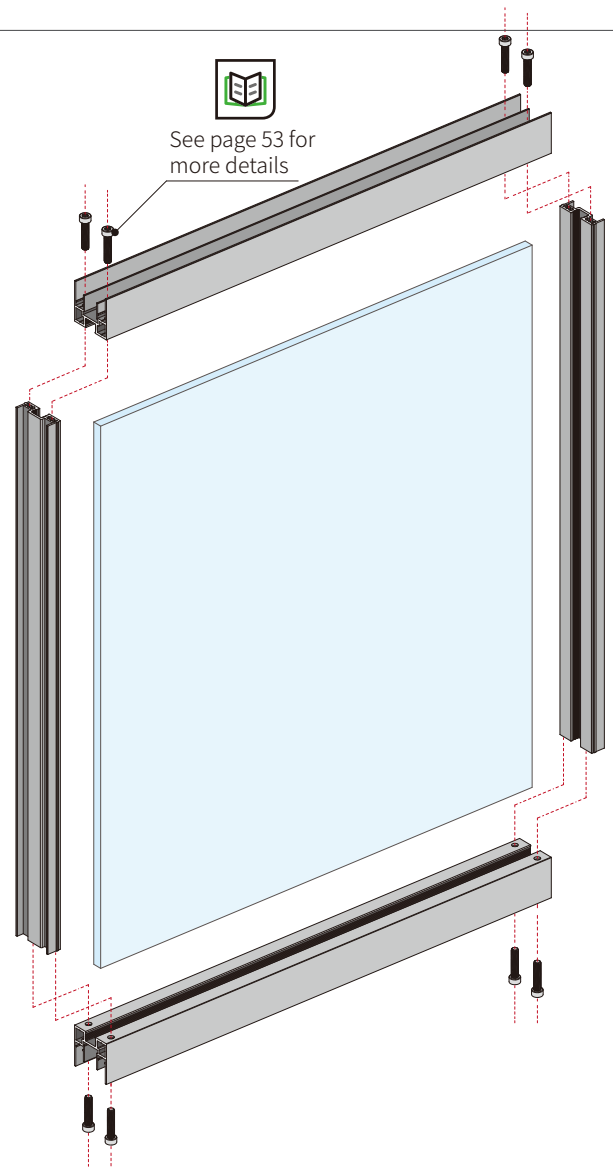
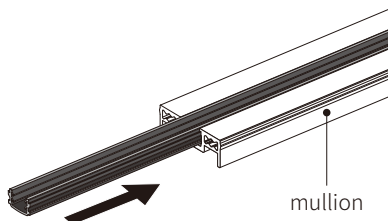
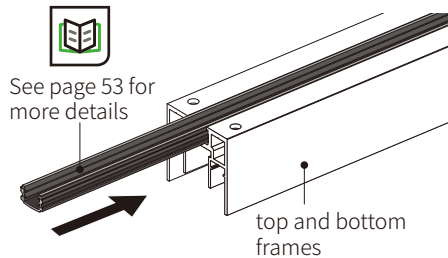

## System analysis

- Auxiliary accessories system
- Door frame auxiliary accessories

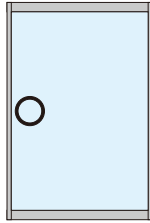
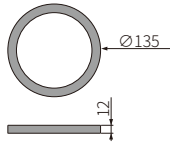

### Technology general situation

- Material: Aluminum Alloy
- Surface Treatment:

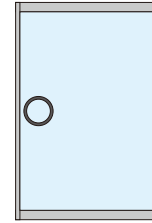
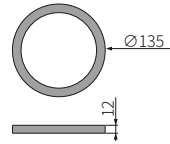

### Technology general situation

- Material: Aluminum Alloy
- Surface Treatment:



Product name	Model Number	SAP code
Perfect Round Handle # 1 (Two-color)135mm_Perfect metal black	OPK-A533	CA991626-001
Perfect Round Handle # 1 (Two-color)135mm_Perfect porcelain Swimming Ash	OPK-A533	CA991626-002
Perfect Round Handle # 1 (Two-color)135mm_Perfect Mocaffine	OPK-A533	CA991626-003
Perfect Round Handle # 1 (Two-color)135mm_Perfect moonlight grey	OPK-A533	CA991626-004

Product name	Model Number	SAP code
Perfect Round Handle # 1 (one-color)135mm_Perfect metal black	OPK-A534	CA991629-001
Perfect Round Handle # 1 (one-color)135mm_Perfect porcelain Swimming Ash	OPK-A534	CA991629-002
Perfect Round Handle # 1 (one-color)135mm_Perfect Mocaffine	OPK-A534	CA991629-003
Perfect Round Handle # 1 (one-color)135mm_Perfect moonlight grey	OPK-A534	CA991629-004

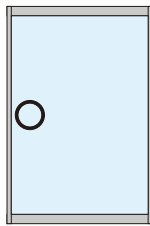
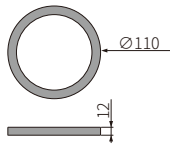

### Technology general situation

- Material: Aluminum Alloy
- Surface Treatment:

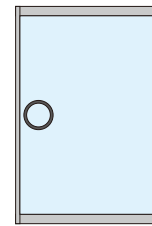
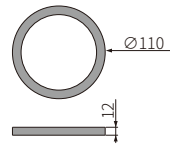

### Technology general situation

- Material: Aluminum Alloy
- Surface Treatment:

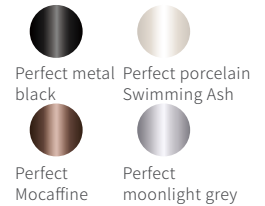

Product name	Model Number	SAP code
Perfect Round Handle # 1 (Two-color)110mm_Perfect metal black	OPK-A535	CA991627-001
Perfect Round Handle # 1 (Two-color)110mm_Perfect porcelain Swimming Ash	OPK-A535	CA991627-002
Perfect Round Handle # 1 (Two-color)110mm_Perfect Mocaffine	OPK-A535	CA991627-003
Perfect Round Handle # 1 (Two-color)110mm_Perfect moonlight grey	OPK-A535	CA991627-004

Product name	Model Number	SAP code
Perfect Round Handle # 1 (one-color) 110mm_Perfect metal black	OPK-A536	CA991628-001
Perfect Round Handle # 1 (one-color) 110mm_Perfect porcelain Swimming Ash	OPK-A536	CA991628-002
Perfect Round Handle # 1 (one-color) 110mm_Perfect Mocaffine	OPK-A536	CA991628-003
Perfect Round Handle # 1 (one-color) 110mm_Perfect moonlight grey	OPK-A536	CA991628-004

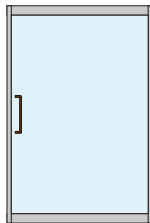
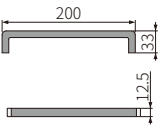

### Technology general situation

- Material: Aluminum Alloy
- Surface Treatment:

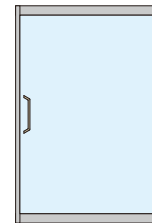
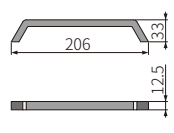

### Technology general situation

- Material: Aluminum Alloy
- Surface Treatment:



Product name	Inner Packing Specification	Outer Packing Specification	Model Number	SAP code
Perfect U-shaped handle # 1	Perfect metal black	Ten boxes/box	20 boxes/case	OPK-A519 CA991574-007
	Perfect porcelain Swimming Ash	Ten boxes/box	20 boxes/case	OPK-A519 CA991574-008
	Perfect Mocaffine	Ten boxes/box	20 boxes/case	OPK-A519 CA991574-006
	Perfect moonlight grey	Ten boxes/box	20 boxes/case	OPK-A519 CA991574-009

Product name	Inner Packing Specification	Outer Packing Specification	Model Number	SAP code
Perfect boat type handle # 1	Perfect metal black	Ten boxes/box	20 boxes/case	OPK-A518 CA991574-011
	Perfect porcelain Swimming Ash	Ten boxes/box	20 boxes/case	OPK-A518 CA991574-012
	Perfect Mocaffine	Ten boxes/box	20 boxes/case	OPK-A518 CA991574-010
	Perfect moonlight grey	Ten boxes/box	20 boxes/case	OPK-A518 CA991574-013

Use technology to perfect life, And to make industry-benign sustainable development



## System analysis

- Auxiliary accessories system
- Door frame auxiliary accessories

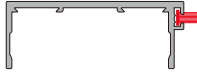

### Usage Instruction

- Use with door mullion (External clasp)

Product name	Inner Packing Specification	Outer Packing Specification	Model Number	SAP code
Sealing strip for clasp	500 m/roll	4 roll/case	OPK-A403	653926

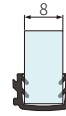

### Technical overview

- Material: PVC
- Finish Treatment: Black

### Usage Instruction

- Can be used for 8mm thick single glass

Product name	Inner Packing Specification	Outer Packing Specification	Model Number	SAP code
8mm Glass rubber strip	3.5m/piece	100 strips/tie	OPK-A408	653889



### Technical overview

- Material: PVC
- Finish Treatment: Black

### Usage Instruction

- can be used for 4mm+4mm thick laminated glass

Product name	Inner Packing Specification	Outer Packing Specification	Model Number	SAP code
9mm Glass rubber strip	3.5m/piece	100 strips/tie	OPK-A409	653822

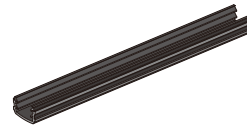

### Technical overview

- Material: PVC
- Finish Treatment: Black

### Usage Instruction

- Can be used for 10mm thick single glass

Product name	Inner Packing Specification	Outer Packing Specification	Model Number	SAP code
10mm Glass rubber strip	3.5m/piece	100 strips/tie	OPK-A410	653890

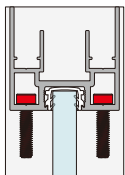
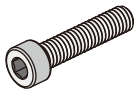

### Technical overview

- Material: carbon steel
- Surface Treatment: nickel plating

### Usage Instruction

- For the connection of the door system
- Eight piece for a door

Product name	Inner Packing Specification	Outer Packing Specification	Model Number	SAP code
internal Hexagonal self-tapping machine wire	500 piece/bag	24 bag/case	OPK-A503	141325

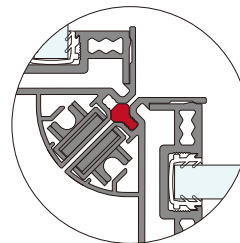
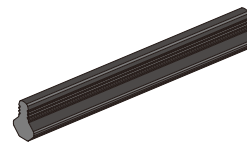

### Technical overview

- Material: rubber
- Surface Treatment: Black

### Usage Instruction

- For shock-proof and dust-proof synchronized decorative door cover

Product name	Inner Packing Specification	Outer Packing Specification	Model Number	SAP code
Right angle synchronized sealing rubber strip	400m/roll	2roll/case	OPK-A405	653763



## Application scheme

- Hanging sliding 3 linkage door
- The visible track without door cover



### Door Opening Top View

#### Door hole door fan width minus ruler rule

**⚠** Theoretical parameters only for reference, and the accuracy and error are adjusted according to the actual situation

