

System analysis

- Sliding roller system
- Hanging sliding roller accessory kit

Perfect A01-G Hanging sliding roller Medium damping for Single door set(High equipment)	Inner Packing Specification	Outer Packing Specification	SAP Code
	1 set/box	20 boxes/case	CA420001-002

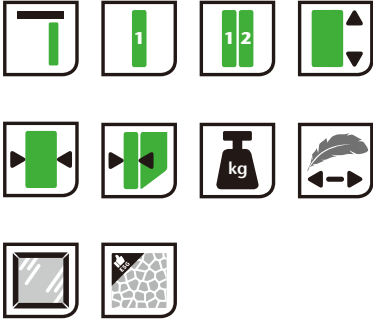

Single door width	≥600mm
Single door thickness	40 or 45mm
Suitable for Glass Thickness	8~11mm
Single door load bearing	≤80kg

Order instructions

- Please order the profiles and tracks separately
- OVERLAP SLIDING 2 DOORS: Please order 2 sets of Perfect A01-G Hanging sliding roller Medium damping for Single door set(High equipment)

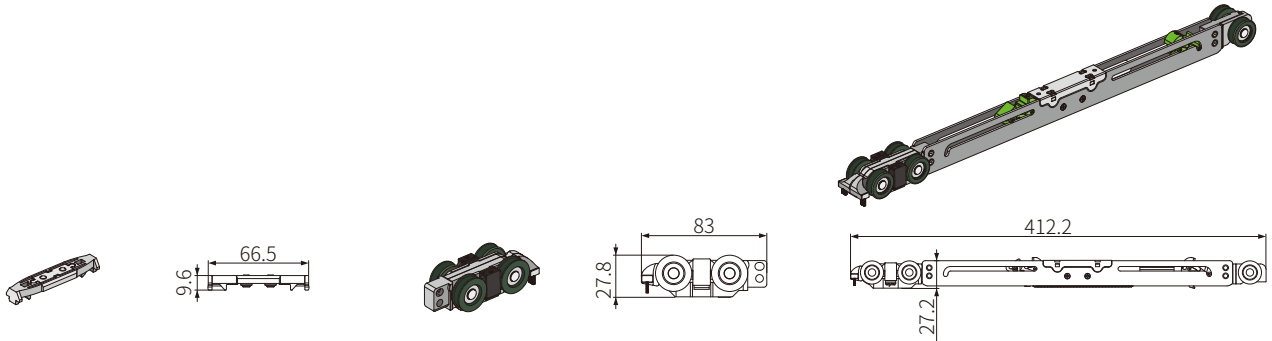

Product name	Quantity	SAP Code	Product name	Quantity	SAP Code	Product name	Quantity	SAP Code
Stopper	x2	CA991385-001	Single hanging sliding roller	x1	CA991383-001	Two-way damping hanging sliding roller	x1	CA991384-001

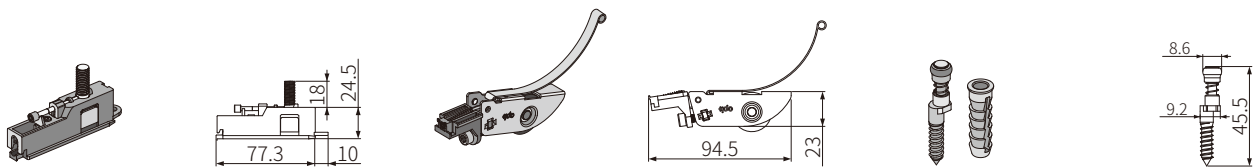

Product name	Quantity	SAP Code	Product name	Quantity	SAP Code	Product name	Quantity	SAP Code
Perfect A01-Hanging Box	x2	CA991441-001	Anti-swing wheel	x2	CA991387-001	the floor guide wheel	x1	CA991393-001

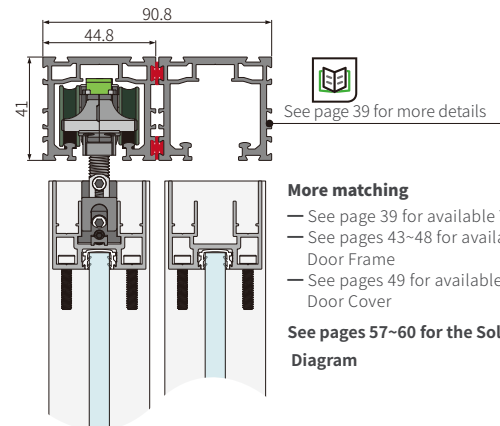

More matching

- See page 39 for available Tracks
- See pages 43~48 for available Door Frame
- See pages 49 for available Door Cover

See pages 57~60 for the Solution Diagram

System analysis

- Sliding roller system
- Schematic diagram of the Hanging sliding roller Installation

Split sliding roller Installation

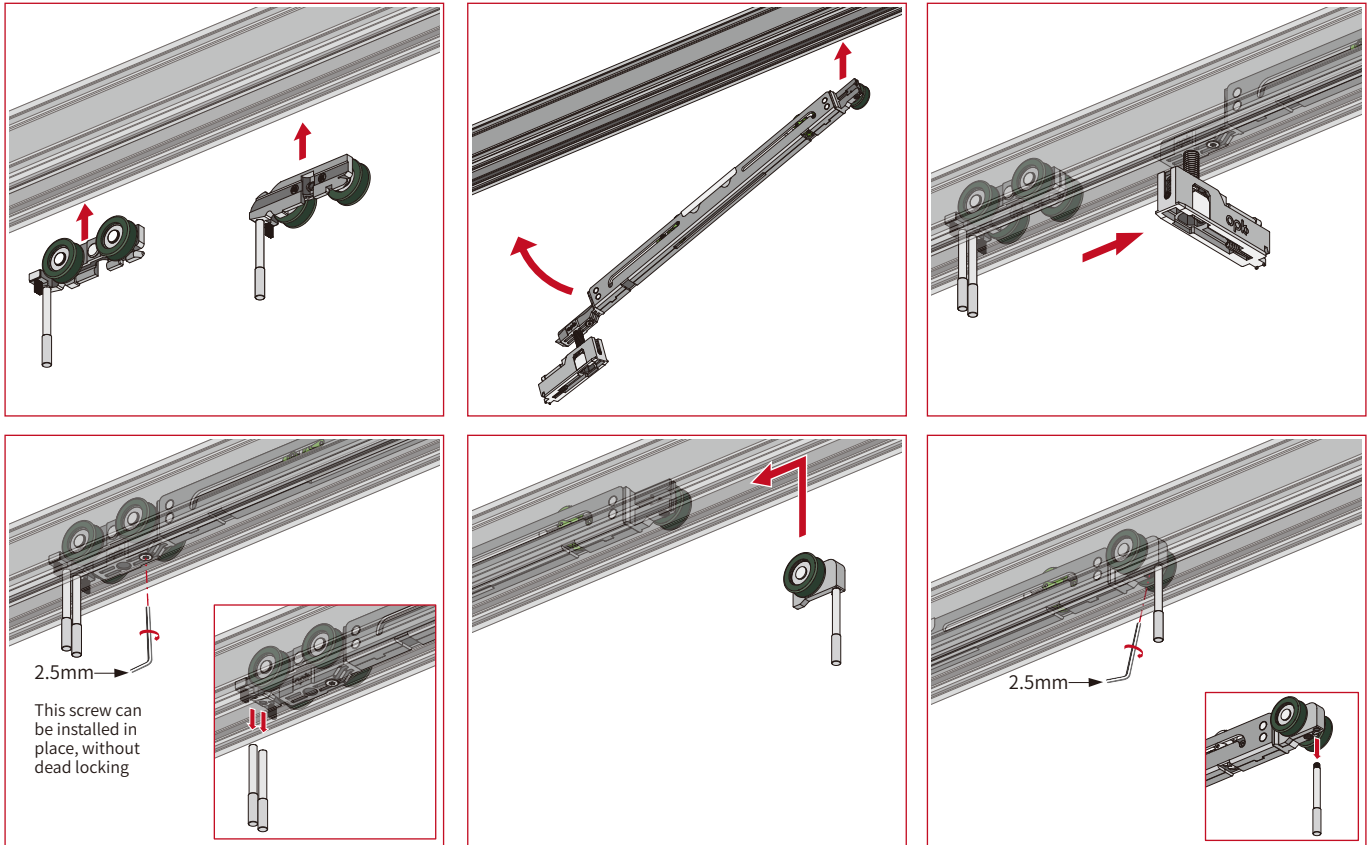

after-installing damper

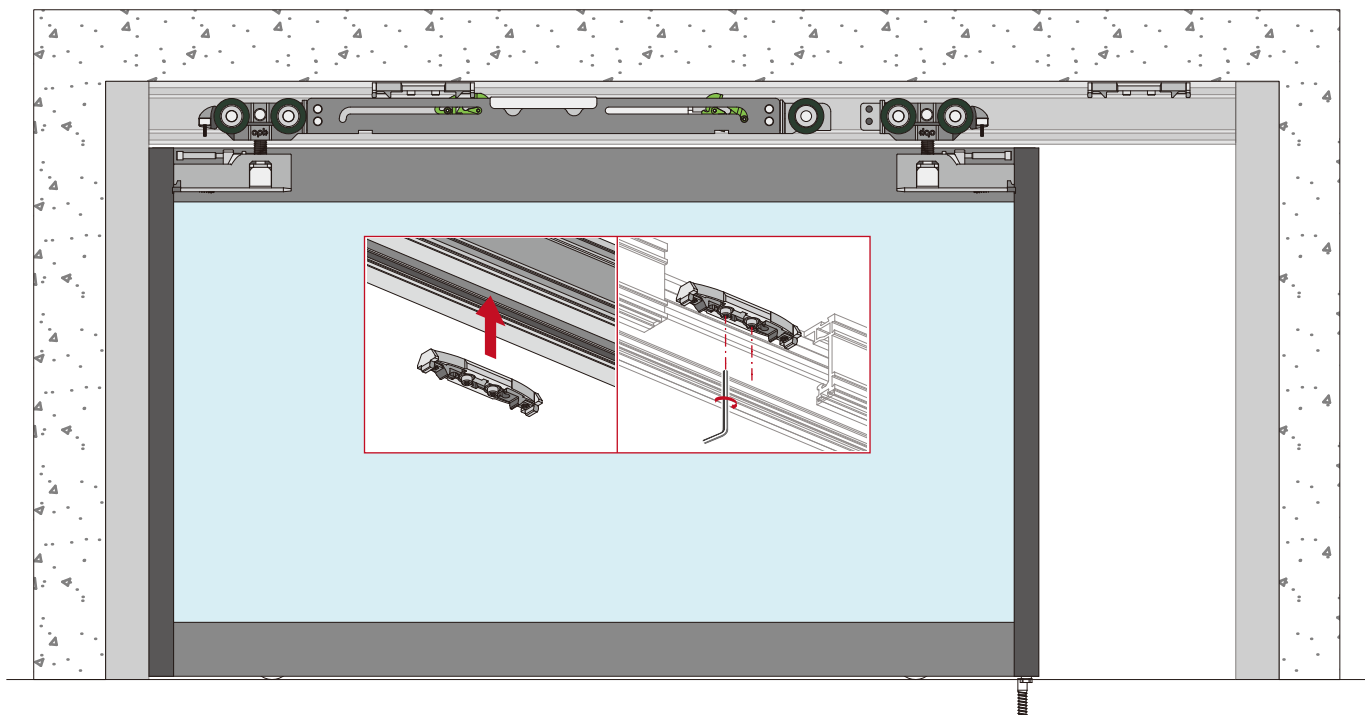

System analysis

- Track system
- Hanging sliding track profile

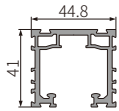
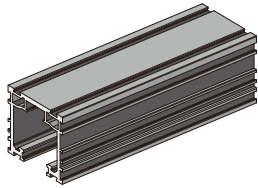

Technical Overview

- Meter Weight:1.35kg/m
- Material:Aluminum Alloy
- Surface Treatment:oxidized flat light black
- Length:6000mm

Usage Instructions

- Used with the Hanging sliding roller system
- Length can be customized according to demand
- Pre-drilling and Screw fixation

Product name	Model Number
Hanging sliding track	OPK-A101

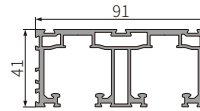
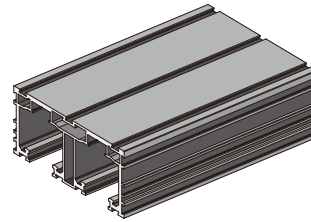

Technical Overview

- Meter Weight:2.14kg/m
- Material:Aluminum Alloy
- Surface Treatment:oxidized flat light black
- Length:6000mm

Usage Instructions

- Apply to 2 Overlap sliding doors
- can be combined with the Hanging sliding track into 3 Linkage door or 2 Linkage doors with one free door
- Length can be customized according to demand
- Pre-drilling and Screw fixation

Product name	Model Number
40Hanging sliding double track	OPK-A114-40

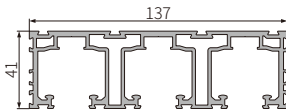
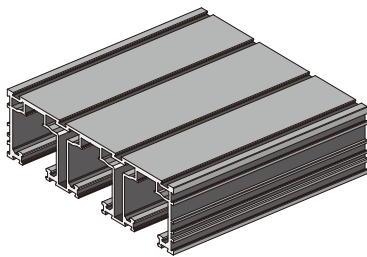

Technical Overview

- Material:Aluminum Alloy
- Surface Treatment:oxidized flat light black
- Length:6000mm

Usage Instructions

- Used with the Hanging sliding roller system
- Apply to 3 Linkage door or 2 Linkage doors with one free door

Product name	Model Number
40 Hanging Sliding Roller Track for 3 Sliding Track	OPK-A116-40

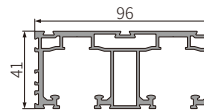
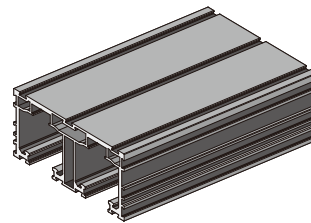

Technical Overview

- Material:Aluminum Alloy
- Surface Treatment:oxidized flat light black
- Length:6000mm

Usage Instructions

- Apply to 2 Overlap sliding doors
- can be combined with the Hanging sliding track into 3 Linkage door or 2 Linkage doors with one free door
- Length can be customized according to demand
- Pre-drilling and Screw fixation

Product name	Model Number
45 Hanging Sliding Roller Track for Double Sliding Track	OPK-A118-45

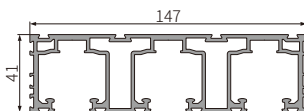
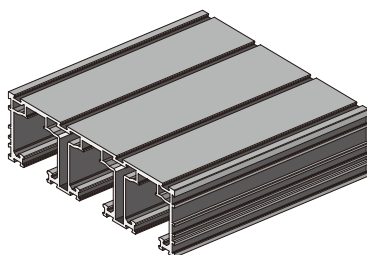

Technical Overview

- Material:Aluminum Alloy
- Surface Treatment:oxidized flat light black
- Length:6000mm

Usage Instructions

- Used with the Hanging sliding roller system
- Apply to 3 Linkage door or 2 Linkage doors with one free door

Product name	Model Number
45 Hanging Sliding Roller Track for 3 Sliding Track	OPK-A120-45

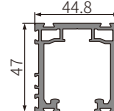
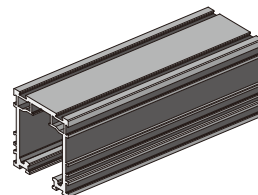

Technical Overview

- Meter Weight:1.21kg/m
- Material:Aluminum Alloy
- Surface Treatment:oxidized flat light black
- Length:6000mm

Usage Instructions

- apply to Synchronized Linkage Door
- Length can be customized according to demand
- Pre-drilling and Screw fixation

Product name	Model Number
Hanging sliding high track(apply to Synchronized Linkage Door)	OPK-A102

System analysis

- Track system
- Hanging sliding track profile

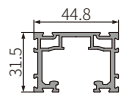
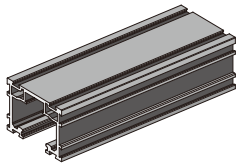

Technical Overview

- Meter Weight: 0.99kg/m
- Material: Aluminum Alloy
- Surface Treatment: oxidized flat light black
- Length: 6000mm

Usage Instructions

- Pair with the Perfect system-30 low track opposite damping hanging sliding track set
- Length can be customized according to demand
- Pre-drilling and Screw fixation

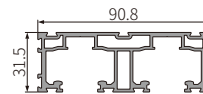
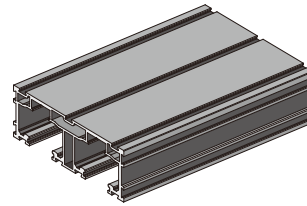

Technical Overview

- Meter Weight: 1.77kg/m
- Material: Aluminum Alloy
- Surface Treatment: oxidized flat light black
- Length: 6000mm

Usage Instructions

- Pair with the Perfect system-30 low track opposite damping hanging sliding track set
- Length can be customized according to demand
- Pre-drilling and Screw fixation

Product name	Model Number
Hanging sliding low track	OPK-A123

Product name	Model Number
40 Hanging sliding low double track	OPK-A124-40

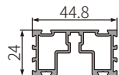
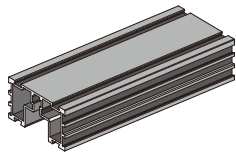

Technical Overview

- Meter Weight: 0.68kg/m
- Material: Aluminum Alloy
- Surface Treatment: oxidized flat light black
- Length: 6000mm

Product name	Model Number
The Bottom load-bearing is matched with the Top sliding track	OPK-A112

System analysis

- Door frame system
- 4016 door frame

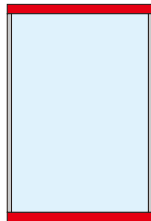
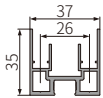
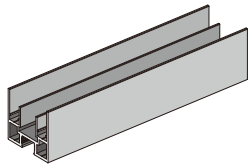

Technical Overview

- Meter Weight: 0.76kg/m
- Material: Aluminum Alloy
- Surface Treatment: Enamelled copper/Cypress grey/Titanium void grey
- Length: 6000mm

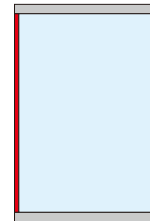
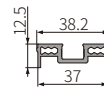
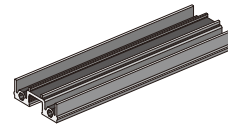

Technical Overview

- Meter Weight: 0.45kg/m
- Material: Aluminum Alloy
- Surface Treatment: Enamelled copper/Cypress grey/Titanium void grey
- Length: 6000mm

Product name	Model Number	Product name	Model Number
40 door frame top and bottom frame	OPK-A201-40	40 door frame mullion(inside)	OPK-A202-40

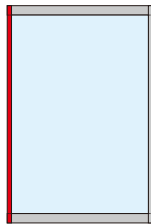
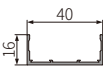
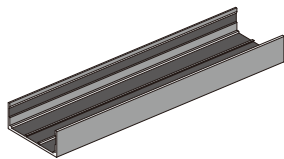

Technical Overview

- Meter Weight: 0.27kg/m
- Material: Aluminum Alloy
- Surface Treatment: Enamelled copper/Cypress grey/Titanium void grey
- Length: 6000mm

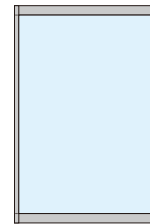
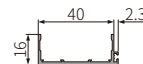
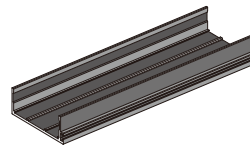

Technical Overview

- Meter Weight: 0.29kg/m
- Material: Aluminum Alloy
- Surface Treatment: Enamelled copper/Cypress grey/Titanium void grey
- Length: 6000mm

Product name	Model Number	Product name	Model Number
40 door frame mullion(outside)	OPK-A203-40	40 door frame mullion(External clasp)	OPK-A204-40

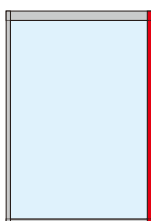
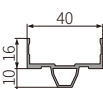
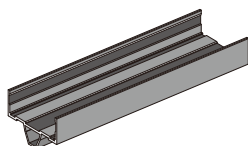

Technical Overview

- Meter Weight: 0.35kg/m
- Material: Aluminum Alloy
- Surface Treatment: Enamelled copper/Cypress grey/Titanium void grey
- Length: 6000mm

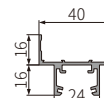
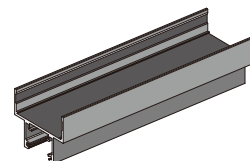

Technical Overview

- Meter Weight: 0.48kg/m
- Material: Aluminum Alloy
- Surface Treatment: Enamelled copper/Cypress grey/Titanium void grey
- Length: 6000mm

Product name	Model Number	Product name	Model Number
40 synchronized door cover A	OPK-A207-40	40 synchronized door cover B	OPK-A208-40

System analysis

- Door frame system
- 4016 door frame

Technical Overview

- Meter Weight: 0.41kg/m
- Material: Aluminum Alloy
- Surface Treatment: Enamelled copper/Cypress grey/Titanium void grey
- Length: 6000mm

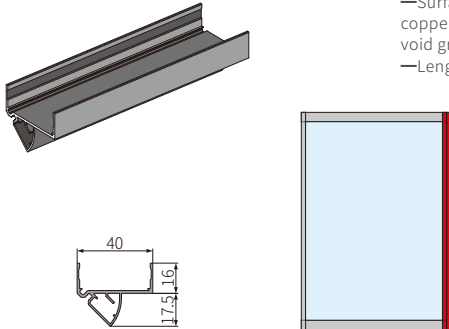

Product name	Model Number
40 right-angle synchronized door cover (arc surface)	OPK-A206-40

— Schematic diagram of the Door frame system Installation

Top and bottom horizontal frame opening dimensions

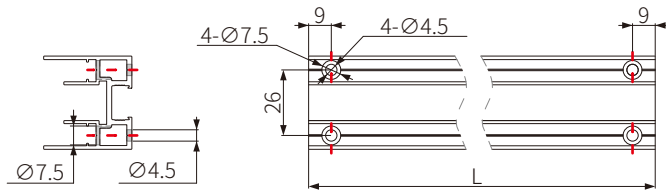

Install glass rubber strips

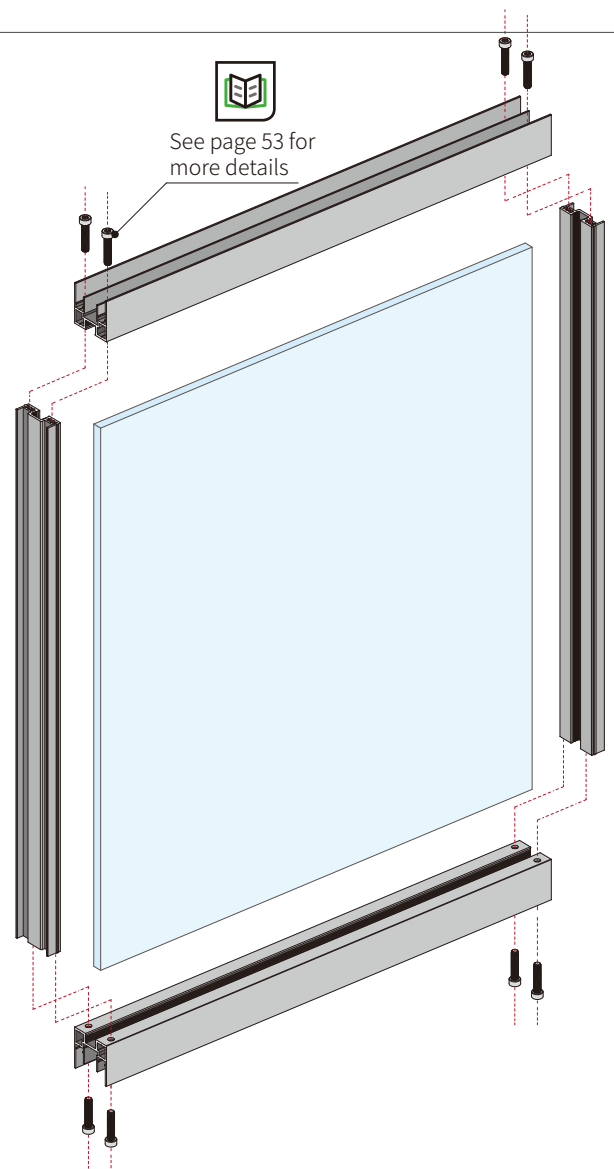
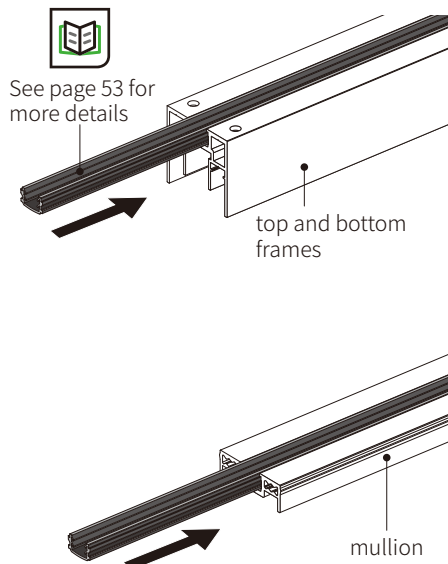

System analysis

- Auxiliary accessories system
- Door frame auxiliary accessories

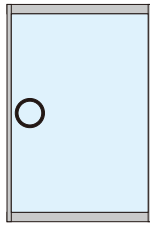
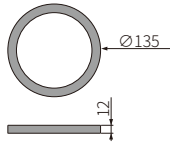

Technology general situation

- Material: Aluminum Alloy
- Surface Treatment:



Technology general situation

- Material: Aluminum Alloy
- Surface Treatment:



Product name	Model Number	SAP code
Perfect Round Handle # 1 (Two-color)135mm_Perfect metal black	OPK-A533	CA991626-001
Perfect Round Handle # 1 (Two-color)135mm_Perfect porcelain Swimming Ash	OPK-A533	CA991626-002
Perfect Round Handle # 1 (Two-color)135mm_Perfect Mocaffine	OPK-A533	CA991626-003
Perfect Round Handle # 1 (Two-color)135mm_Perfect moonlight grey	OPK-A533	CA991626-004

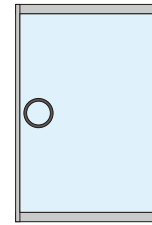
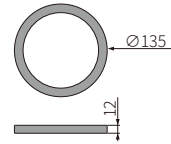
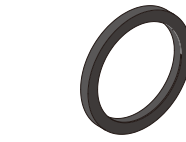

Product name	Model Number	SAP code
Perfect Round Handle # 1 (one-color)135mm_Perfect metal black	OPK-A534	CA991629-001
Perfect Round Handle # 1 (one-color)135mm_Perfect porcelain Swimming Ash	OPK-A534	CA991629-002
Perfect Round Handle # 1 (one-color)135mm_Perfect Mocaffine	OPK-A534	CA991629-003
Perfect Round Handle # 1 (one-color)135mm_Perfect moonlight grey	OPK-A534	CA991629-004

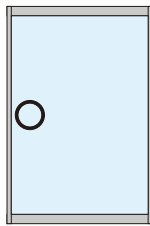
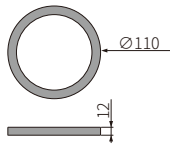

Technology general situation

- Material: Aluminum Alloy
- Surface Treatment:



Technology general situation

- Material: Aluminum Alloy
- Surface Treatment:



Product name	Model Number	SAP code
Perfect Round Handle # 1 (Two-color)110mm_Perfect metal black	OPK-A535	CA991627-001
Perfect Round Handle # 1 (Two-color)110mm_Perfect porcelain Swimming Ash	OPK-A535	CA991627-002
Perfect Round Handle # 1 (Two-color)110mm_Perfect Mocaffine	OPK-A535	CA991627-003
Perfect Round Handle # 1 (Two-color)110mm_Perfect moonlight grey	OPK-A535	CA991627-004

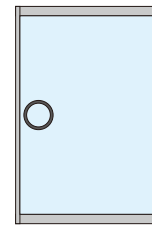
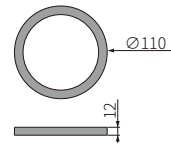
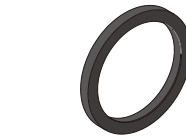

Product name	Model Number	SAP code
Perfect Round Handle # 1 (one-color) 110mm_Perfect metal black	OPK-A536	CA991628-001
Perfect Round Handle # 1 (one-color) 110mm_Perfect porcelain Swimming Ash	OPK-A536	CA991628-002
Perfect Round Handle # 1 (one-color) 110mm_Perfect Mocaffine	OPK-A536	CA991628-003
Perfect Round Handle # 1 (one-color) 110mm_Perfect moonlight grey	OPK-A536	CA991628-004

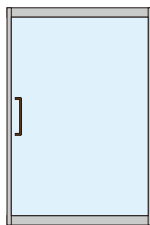
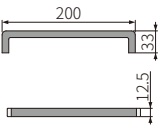
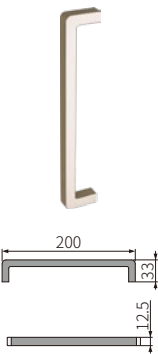

Technology general situation

- Material: Aluminum Alloy
- Surface Treatment:



Technology general situation

- Material: Aluminum Alloy
- Surface Treatment:



Product name	Inner Packing Specification	Outer Packing Specification	Model Number	SAP code
Perfect U-shaped handle # 1	Perfect metal black	Ten boxes/box	20 boxes/case	OPK-A519 CA991574-007
	Perfect porcelain Swimming Ash	Ten boxes/box	20 boxes/case	OPK-A519 CA991574-008
	Perfect Mocaffine	Ten boxes/box	20 boxes/case	OPK-A519 CA991574-006
	Perfect moonlight grey	Ten boxes/box	20 boxes/case	OPK-A519 CA991574-009

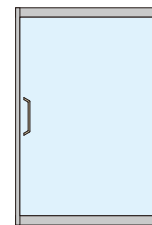
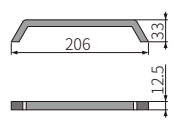

Product name	Inner Packing Specification	Outer Packing Specification	Model Number	SAP code
Perfect boat type handle # 1	Perfect metal black	Ten boxes/box	20 boxes/case	OPK-A518 CA991574-011
	Perfect porcelain Swimming Ash	Ten boxes/box	20 boxes/case	OPK-A518 CA991574-012
	Perfect Mocaffine	Ten boxes/box	20 boxes/case	OPK-A518 CA991574-010
	Perfect moonlight grey	Ten boxes/box	20 boxes/case	OPK-A518 CA991574-013

Use technology to perfect life, And to make industry-benign sustainable development

System analysis

- Auxiliary accessories system
- Door frame auxiliary accessories

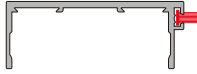
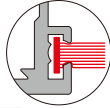

Usage Instruction

- Use with door mullion (External clasp)

Product name	Inner Packing Specification	Outer Packing Specification	Model Number	SAP code
Sealing strip for clasp	500 m/roll	4 roll/case	OPK-A403	653926

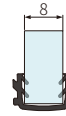

Technical overview

- Material: PVC
- Finish Treatment: Black

Usage Instruction

- Can be used for 8mm thick single glass

Product name	Inner Packing Specification	Outer Packing Specification	Model Number	SAP code
8mm Glass rubber strip	3.5m/piece	100 strips/tie	OPK-A408	653889



Technical overview

- Material: PVC
- Finish Treatment: Black

Usage Instruction

- can be used for 4mm+4mm thick laminated glass

Product name	Inner Packing Specification	Outer Packing Specification	Model Number	SAP code
9mm Glass rubber strip	3.5m/piece	100 strips/tie	OPK-A409	653822

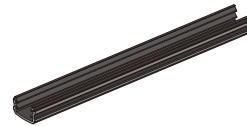

Technical overview

- Material: PVC
- Finish Treatment: Black

Usage Instruction

- Can be used for 10mm thick single glass

Product name	Inner Packing Specification	Outer Packing Specification	Model Number	SAP code
10mm Glass rubber strip	3.5m/piece	100 strips/tie	OPK-A410	653890

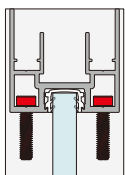
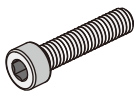

Technical overview

- Material: carbon steel
- Surface Treatment: nickel plating

Usage Instruction

- For the connection of the door system
- Eight piece for a door

Product name	Inner Packing Specification	Outer Packing Specification	Model Number	SAP code
internal Hexagonal self-tapping machine wire	500 piece/bag	24 bag/case	OPK-A503	141325

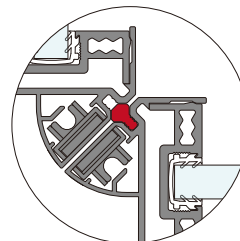
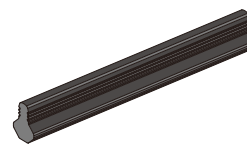

Technical overview

- Material: rubber
- Surface Treatment: Black

Usage Instruction

- For shock-proof and dust-proof synchronized decorative door cover

Product name	Inner Packing Specification	Outer Packing Specification	Model Number	SAP code
Right angle synchronized sealing rubber strip	400m/roll	2roll/case	OPK-A405	653763

Application scheme

- 2-Hanging Overlap sliding doors
- The visible track without door cover



Door Opening Top View

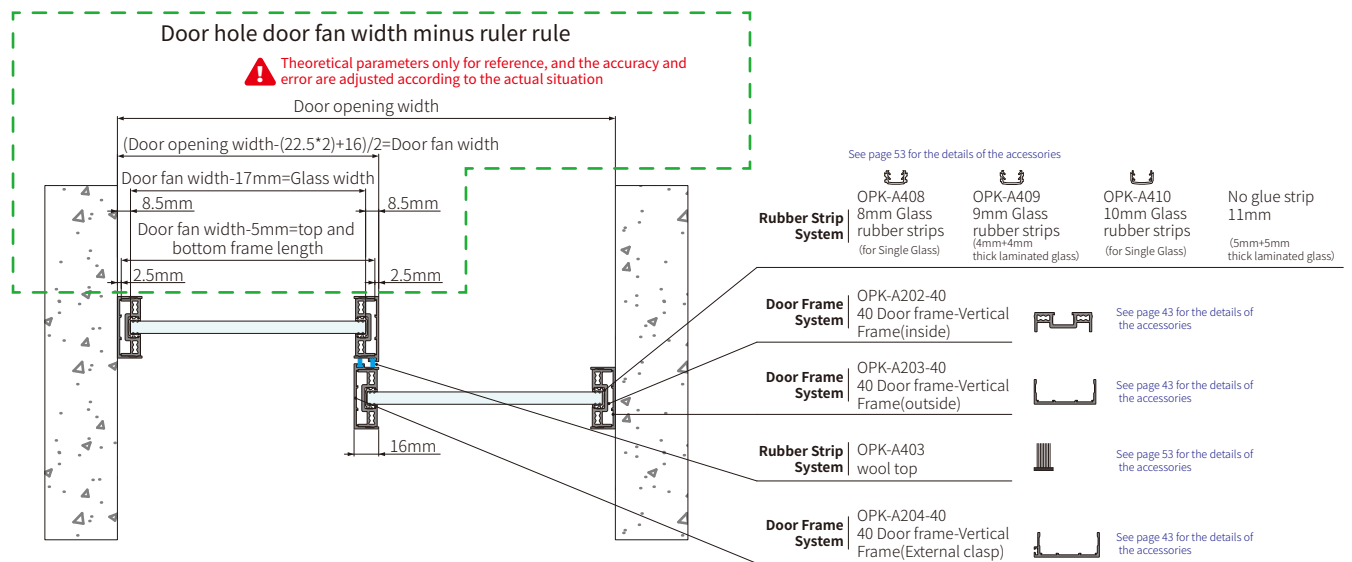

Application scheme

- 2-Hanging Overlap sliding doors
- The visible track without door cover

Door opening front view

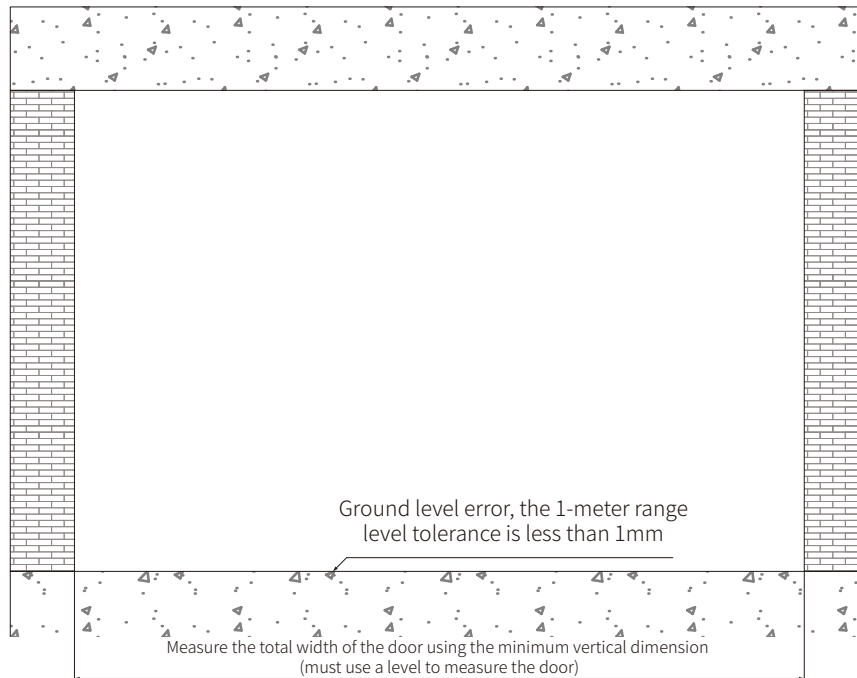

Door opening sectional view

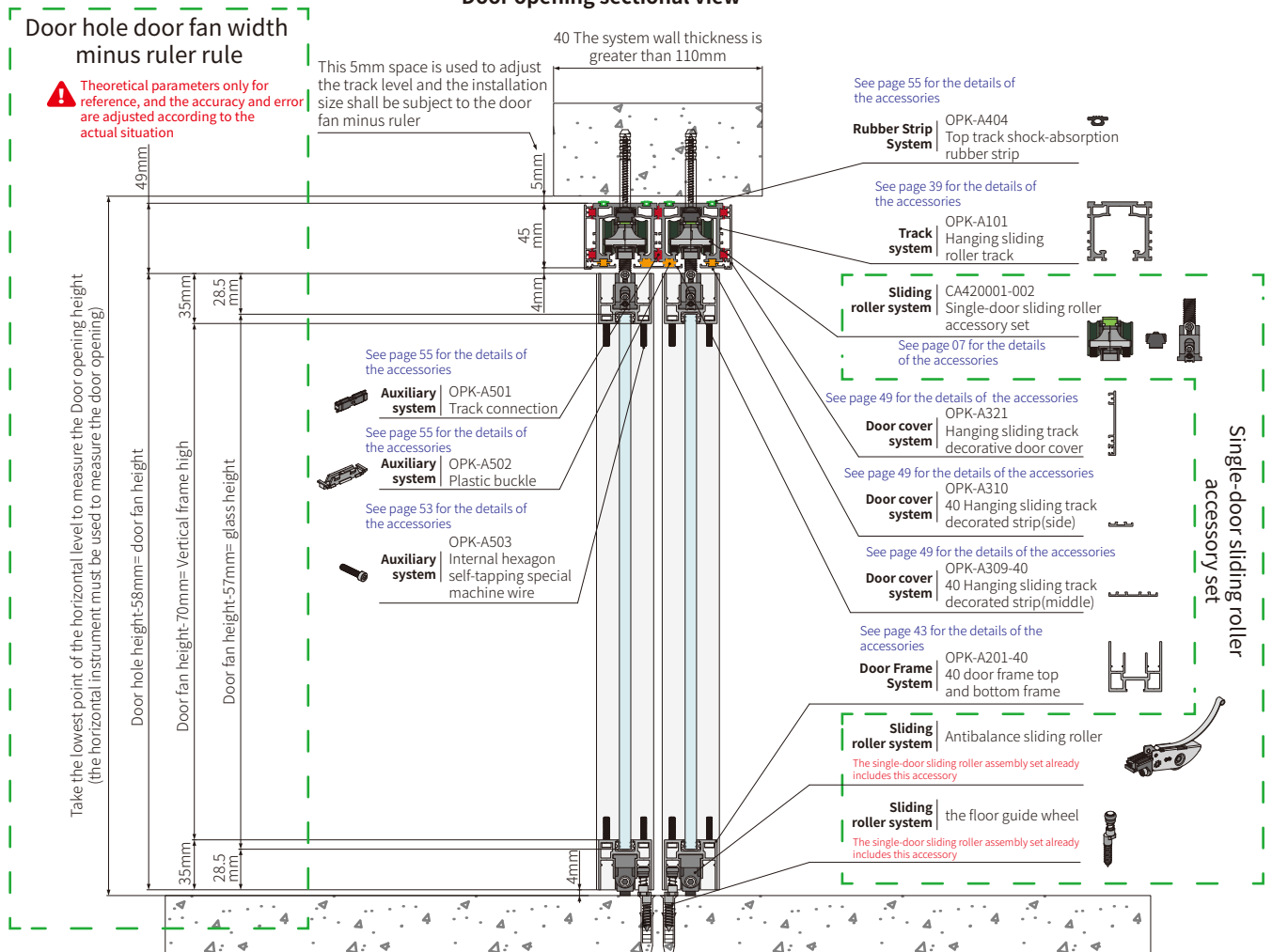

Application scheme

- 2-Hanging Overlap sliding doors
- The hanging concealed track



Door Opening Top View

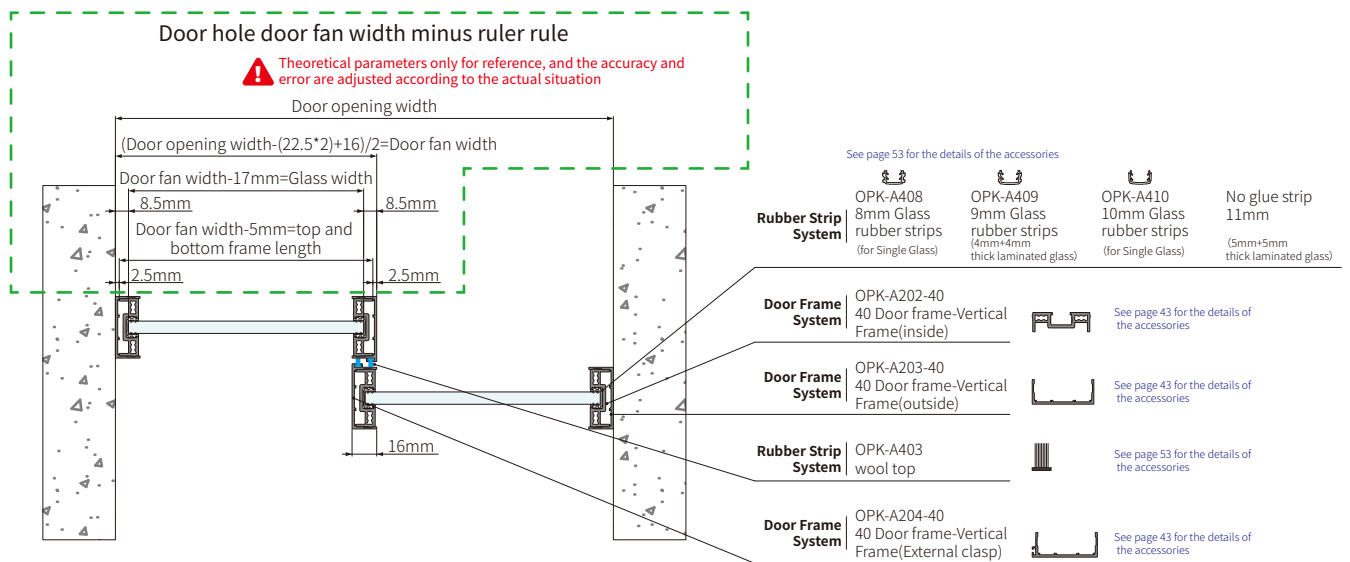

Application scheme

- 2-Hanging Overlap sliding doors
- The hanging concealed track

Door opening front view

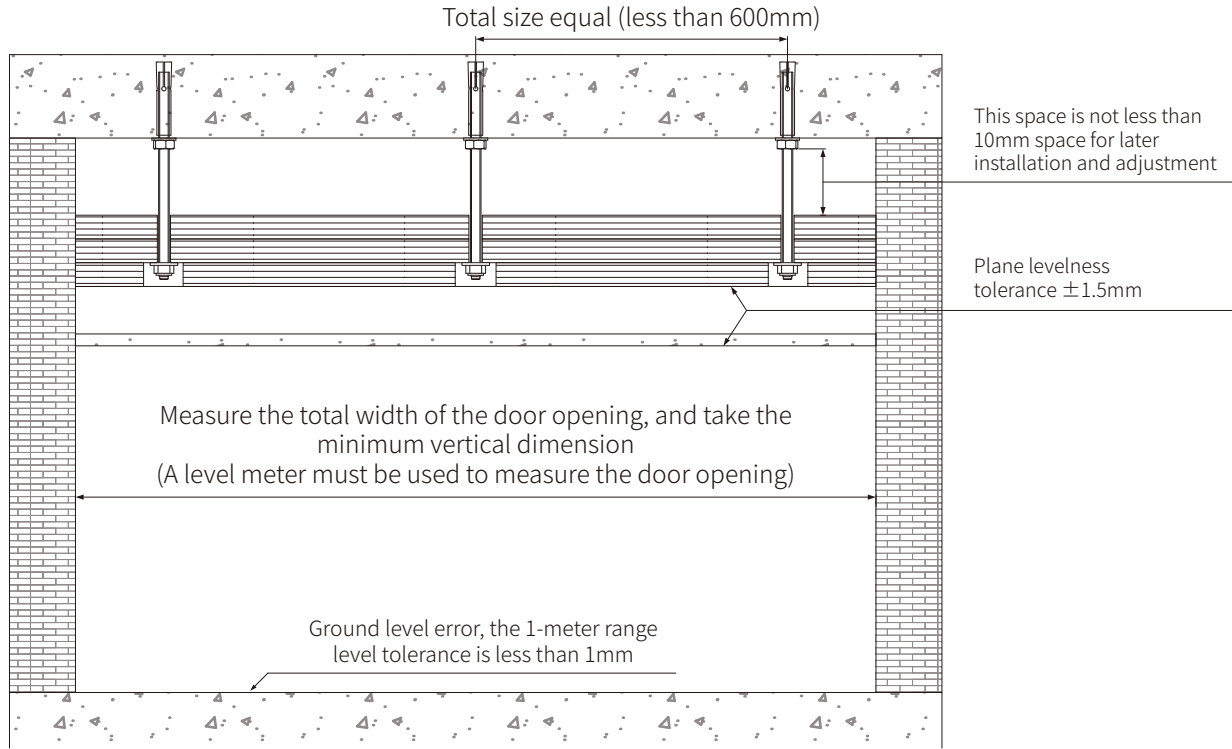

Door opening sectional view

