

## DATA SHEET

### UTS10L1C-xx 10.3125Gbps CWDM 10km SFP+ Transceiver

## Features

- Up to 11.1Gbps Data Links
- Uncooled CWDM DFB Laser and PIN receiver
- Metal enclosure, for lower EMI
- Single +3.3V power supply
- Hot-pluggable
- Power dissipation < 1.5W
- Operating temperature range:  
Commercial: -5°C~+70°C
- RoHS Compliant
- DDMI function available with internally calibrated mode
- Up to 10km transmission distance over Single Mode Fiber(SMF) without CDR inside

## Application

- 10GBASE-LR/LW
- 10G Fiber Channel

## Standard

- Compliant with MSA SFP+ specification(SFF-8431)
- Compliant with SFF-8472
- Compliant with SFP+ MSA
- Compliant to IEEE 802.3ae

## Product selection

Wavelength	xx	Clasp Color Code	Wavelength	xx	Clasp Color Code
1270 nm	27	Aqua	1370 nm	37	Pink
1290 nm	29	Fuchsia	1390 nm	39	Light brown
1310 nm	31	Olive	1410 nm	41	Tawny
1330 nm	33	Lime	1430 nm	43	Beige
1350 nm	35	Sky blue	1450 nm	45	Navy
1470 nm	47	Gray	1550 nm	55	Yellow
1490 nm	49	Purple	1570 nm	57	Orange
1510 nm	51	Blue	1590 nm	59	Red
1530 nm	53	Green	1610 nm	61	Maroon

## Specification

Absolute Maximum Ratings				
Parameter	Symbol	Min	Max	Unit
Storage temperature	TS	-40	85	°C
Power Supply Voltage	Vcc3	-0.3	+4	V
Relative Humidity	RH	5	95	%
Signal Input Voltage		Vcc-0.3	Vcc+0.3	V

Recommended Operating Conditions					
Parameter	Symbol	Min	Typical	Max	Unit
Operating Case Temperature (Commercial)	Tc	-5		70	°C
Power Supply Voltage	Vcc3	3.13	3.3	3.47	V
Supply Current	Icc3			450	mA
Data Rate			10.3125		Gbps
Fiber Length 9/125µm core SMF		-	10	-	km

Electrical Characteristics						
Parameter	Symbol	Min	Typical	Max	Unit	Notes
Transmitter differential input voltage	Vin,pp	180		1200	m V	
Receiver differential output Voltage	Vout,pp	300		850	m V	
Input differential impedance	Rin		100		Ω	1
LOS Fault	VLOS fault	Vcc-1.3		VccHost	V	2
LOS Normal	VLOS norm	Vee		Vee+0.8	V	2

Transmit disable voltage	VIH	Vcc-1.3		Vcc	v	
Transmit enable voltage	VIL	Vee		Vee+0.8	v	
Data output rise time	Tr	30			ps	
Data output fall time	Tf	30			ps	
Transmit Disable Assert Time				10	us	
Power Supply Rejection	PSR			100	mVpp	3

**Notes:**

- 1) Connected directly to TX data input pins. AC coupled thereafter.
- 2) Loss Of Signal is LVTTTL. Logic 0 indicates normal operation; logic 1 indicates no signal detected.
- 3) Receiver sensitivity is compliant with power supply sinusoidal modulation of 20 Hz to 1.5 MHz up to specified value applied through the recommended power supply filtering network.

Optical transmitter Characteristics						
Parameter	Symbol	Min	Typical	Max	Unit	Notes
Launched Power (avg.)	Pout	-6		-0.5	dBm	4
Operating Wavelength Range	$\lambda_c$	$\lambda-6.5$		$\lambda+6.5$	nm	5
Spectral Width(-20dB)	$\Delta\lambda$			1	nm	
Side Mode Suppression Ratio	SMSR	30			dB	
Extinction Ratio	ER	3.5			dB	
Transmitter and Dispersion Penalty	TDP			3.2	dB	
Output Eye Diagram	Compliant with ITU-T G.691 eye mask and IEEE802.3ae eye mask					
Optical receiver Characteristics						
Parameter	Symbol	Min	Typical	Max	Unit	Notes
Receiver Sensitivity	S			-14.4	dBm	6
Wavelength Range	$\lambda_c$	1270		1610	nm	
Optical Power Input Overload	P <sub>in-max</sub>	0.5			dBm	
LOS	Optical De-assert	Pd		-17	dBm	
	Optical Assert	Pa	-30			
LOS hysteresis		0.5			dB	

**Notes:**

- 4) Class 1 Laser Safety per FDA/CDRH and IEC-825-1 regulations.
- 5) “ $\lambda$ ” is:1270,1290,1310,1330,1350,1370,1390,1410,1430,1450, 1470,1490,1510,1530,1550,1570,1590,1610, base on the “product selection” .
- 6) Receiver Reflectance Measured with a PRBS 2<sup>31</sup>-1 test pattern, @10.3125Gbps, ER=3.5dB, BER<10<sup>-12</sup>.

## Digital Diagnostic Monitoring Information

UNIVISO UTS10L1C-XX transceivers support the 2-wire serial communication protocol as defined in the SFP+MSA. The standard SFP serial ID provides access to identification information that describes the transceiver’s capabilities, standard interfaces, manufacturer, and other information.

Additionally, SFP+ transceivers provide a unique enhanced digital diagnostic monitoring interface, which allows real-time access to device operating parameters such as transceiver temperature, laser bias current, transmitted optical power, received optical power and transceiver supply voltage. It also defines a sophisticated system of alarm and warning flags, which alerts end-users when particular operating parameters are outside of a factory set normal range.

The SFP+ MSA defines a 256-byte memory map in EEPROM that is accessible over a 2-wire serial interface at the 8 bit address 1010000X (A0h).The digital diagnostic monitoring interface makes use of the 8 bit address 1010001X (A2h), so the originally defined serial ID memory map remains unchanged.

The operating and diagnostics information is monitored and reported by a Digital Diagnostics Transceiver Controller (DDTC) inside the transceiver, which is accessed through a 2-wire serial interface. When the serial protocol is activated, the serial clock signal (SCL, Mod Def 1) is generated by the host. The positive edge clocks data into the SFP transceiver into those segments of the E2PROM that are not write-protected. The negative edge clocks data from the SFP transceiver. The serial data signal (SDA, Mod Def 2) is bi-directional for serial data transfer. The host uses SDA in conjunction with SCL to mark the start and end of serial protocol activation. The memories are organized as a series of 8-bit data words that can be addressed individually or sequentially.

## Pin Descriptions

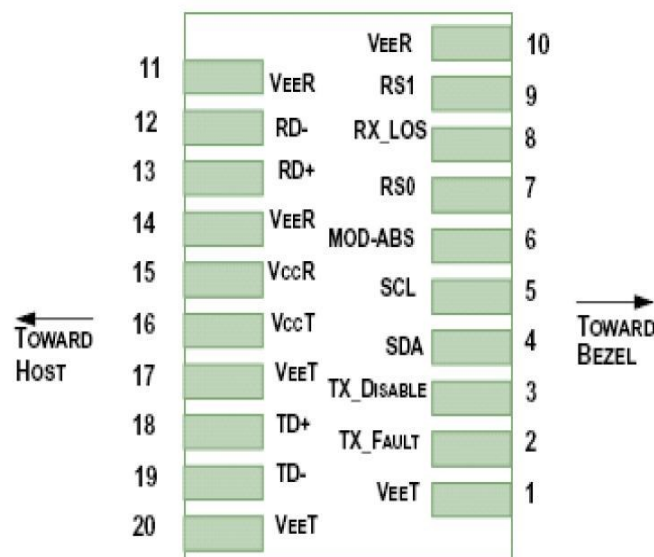

Diagram of Host Board Connector Block Pin Numbers and Name

## Pin Assignment

Pin	Symbol	Description	Notes
1	VeeT	Module Ground(Common with Receiver Ground)	1
2	TX_Fault	Transmitter Fault, Low: normal; High: abnormal	2
3	TX_Disable	Transmitter Disable High: Transmitter off Low: Transmitter on	3
4	SDA	2-Wire Serial Interface Data Line (Same as MOD-DEF2 in INF-8074i)	4
5	SCL	2-Wire Serial Interface Data Line (Same as MOD-DEF2 in INF-8074i)	4
6	Mod_ABS	Module Absent, Connect to VeeT or VeeR in Module	4
7	RS0	Rate Select 0, optionally controls SFP+ module receiver	5
8	RX_LOS	Receiver Loss of Signal indication High: loss of signal Low: signal detected	6
9	RS1	Rate Select 1, optionally controls SFP+ module transmitter	1
10	VeeR	Receiver Ground	1
11	VeeR	Receiver Ground	1
12	RD-	Receiver Inverted DATA out. AC Coupled. CML-O	
13	RD+	Receiver Non-inverted DATA out. AC Coupled. CML-O	
14	VeeR	Receiver Ground	1
15	VccR	Receiver Power Supply	
16	VccT	Transmitter Power Supply	
17	VeeT	Transmitter Ground	1
18	TD+	Transmitter Non-Inverted DATA in. AC Coupled. CML-I	
19	TD-	Transmitter Inverted DATA in. AC Coupled. CML-I	
20	SDA	Transmitter Ground	1

### Notes:

- 1) Circuit ground is internally isolated from chassis ground.
- 2) TFAULT is an open collector/drain output, which should be pulled up with a 4.7k – 10k Ohms resistor on the host board if intended for use. Pull up voltage should be between 2.0V to Vcc + 0.3V. A high output indicates a transmitter fault caused by either the TX bias current or the TX output power exceeding the preset alarm thresholds. A low output indicates normal operation. In the low state, the output is pulled to <0.8V.
- 3) Laser output disabled on TDIS >2.0V or open, enabled on TDIS <0.8V.
- 4) Should be pulled up with 4.7kΩ- 10kΩ host board to a voltage between 2.0V and 3.6V. MOD\_ABS pulls line low to indicate module is plugged in.
- 5) Internally pulled down per SFF-8431 Rev 4.1.
- 6) LOS is open collector output. It should be pulled up with 4.7kΩ – 10kΩ on host board to a voltage between 2.0V and

3.6V. Logic 0 indicates normal operation; logic 1 indicates loss of signal.

### Block Diagram

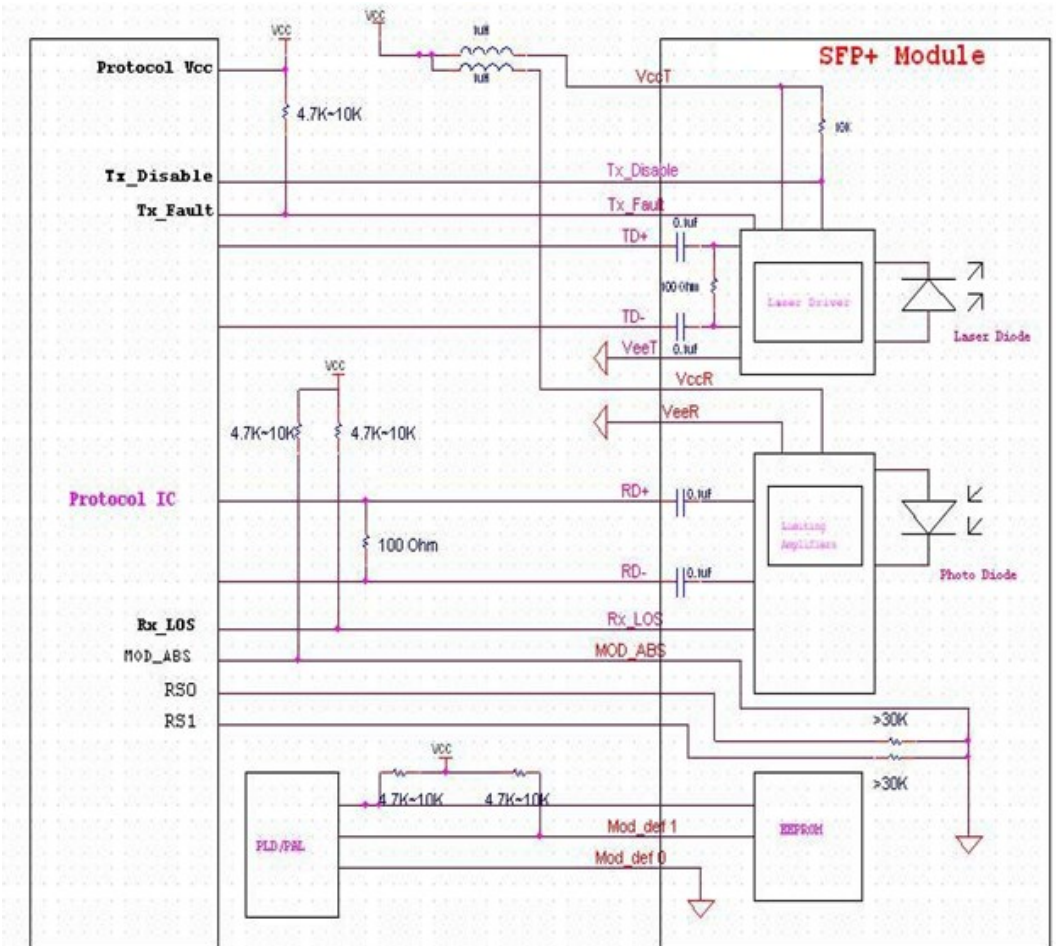

## Package Outline

Dimensions are in millimeters. All dimensions are  $\pm 0.2\text{mm}$  unless otherwise specified. (Unit: mm)

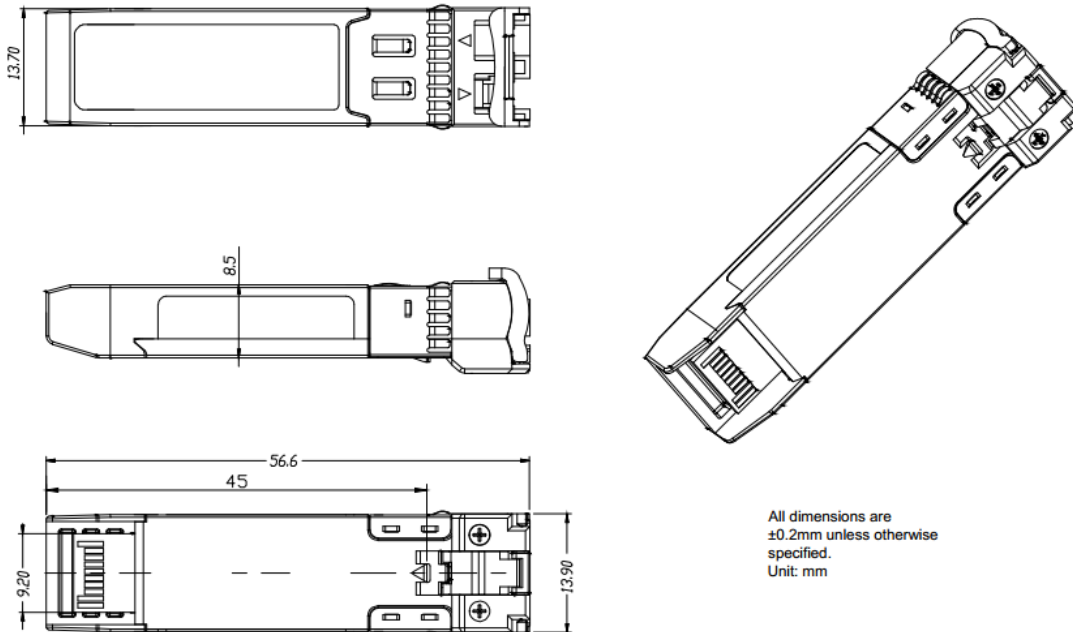

## Regulatory Compliance

Feature	Test	Method
Electrostatic Discharge (ESD) to the Electrical Pins	MIL-STD-883E Method 3015.7	Class 1(>1000V for SFI pins, >2000Vfor other pins.)
Electrostatic Discharge (ESD) Immunity	IEC61000-4-2	Class 2(>4.0kV)
Electromagnetic Interference (EMI)	CISPR22 ITE Class B FCC Class B CENELEC EN55022 VCCI Class 1	Comply with standard
Immunity	IEC61000-4-3	Comply with standard
Eye Safety	FDA 21CFR 1040.10 and 1040.11 EN (IEC) 60825-1,2	Compatible with Class I laser Product

## Ordering information

Part. No	Specifications								
	Pack	Rate (Gbps)	Tx (nm)	Po (dBm)	RX	Sen (dBm)	Temp (°C)	Reach (km)	DDM
UTS10L1C-XX	SFP+	10.3125	CWDM DFB	-6~-0.5	PIN	<-14.4	-5~70	10	Y