

DATA SHEET

USQ1HL2

100Gb/s QSFP28 LR4 Lite Transceiver

PRODUCT FEATURES

- Hot-pluggable QSFP28 MSA form factor
- Duplex LC receptacle optical interface
- Transmitter: cooled 4x25Gb/s DML laser
- Receiver: 4x25Gb/s PIN receiver
- Compliant with CEI-28G-VSR
- Single +3.3V power supply
- Low power dissipation (Max:4.0W)
- Built in digital diagnostic function
- Operating case temperature range: 0°C to 70°C

APPLICATIONS

- 100GBASE-LR4
- Infiniband QDR and DDR interconnects
- Client-side 100G Telecom connections

Functional Description

The 100G QSFP28 LR4 optical transceiver integrates the transmit and receive path onto one module. On the transmit side, four lanes of serial data streams are recovered, retimed, and passed on to four laser drivers, which control four lasers with 1295.5, 1300.0, 1304.5, and 1309.1nm center wavelengths. The optical signals are then multiplexed into a single-mode fiber through an industry-standard LC connector. On the receive side, four lanes of optical data streams are optically demultiplexed by an integrated optical demultiplexer. Each data stream is recovered by a photodetector and transimpedance amplifier, retimed, and passed on to an output driver. This module features a hot-pluggable electrical interface, low power consumption, and 2-wire serial interface.

Functional Diagram

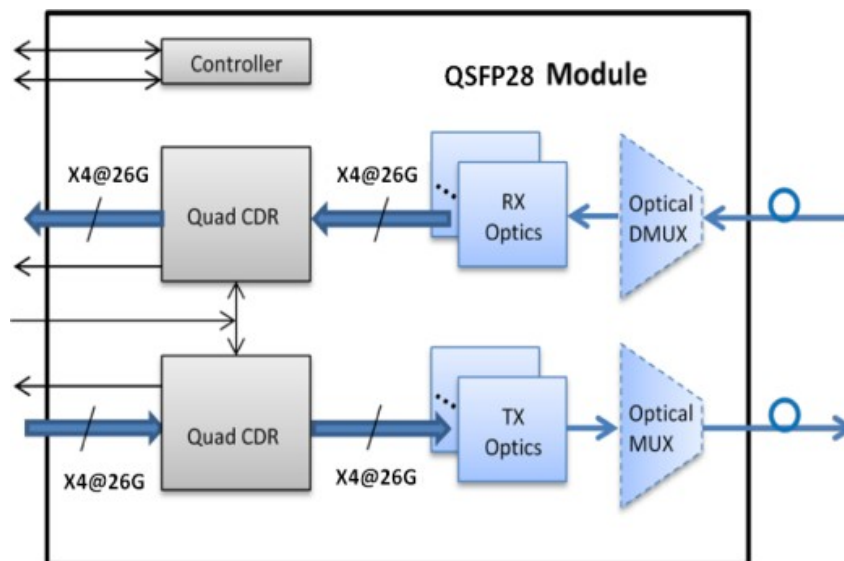

Absolute Maximum Ratings

Parameter	Symbol	Min.	Max.	Unit	Note
Supply Voltage	V_{cc}	-0.5	3.6	V	
Storage Temperature	T_S	-40	85	°C	
Relative Humidity	R_H	0	85	%	
Rx Damage Threshold, per Lane	P_{Rdmg}	5.5		dBm	

Note: Stress in excess of the maximum absolute ratings can cause permanent damage to the transceiver.

Recommended Operating Conditions

Parameter	Symbol	Min.	Typ	Max.	Unit	Note
Data Rate	DR		103.1		Gb/s	
Supply Voltage	V _{cc}	3.14	3.3	3.47	V	
Supply Current	I _{cc}			1.2	A	
Operating Case Temp.	T _c	0		70	°C	

Electrical Characteristics

(Tested under recommended operating conditions, unless otherwise noted)

Parameter	Symbol	Min	Typ	Max	Unit	Notes
Supply Voltage	V _{cc}	3.13	3.3	3.47	V	
Transmitter						
Input differential impedance	R _{in}		100		Ω	1
Differential data input swing	V _{in,pp}	180		1000	mV	
Transmit Disable Voltage	VD	V _{cc} -1.3		V _{cc}	V	
Transmit Enable Voltage	VEN	V _{ee}		V _{ee} + 0.8	V	2
Receiver						
Differential data output swing	V _{out,pp}	300		850	mV	3
LOS Fault	VLOS fault	V _{cc} -1.3		V _{cc} HOST	V	4
LOS Normal	VLOS norm	V _{ee}		V _{ee} +0.8	V	4

Notes:

1. Connected directly to TX data input pins. AC coupled thereafter.
2. Optional for TX disable
3. Into 100 ohms differential termination
4. Loss Of Signal is LVTTTL. Logic 0 indicates normal operation; logic 1 indicates no signal detected.

Optical Characteristics

(Tested under recommended operating conditions, unless otherwise noted)

Parameter	Symbol	Unit	Min	Typ	Max	Notes
Transmitter						

Parameter	Symbol	Unit	Min	Typ	Max	Notes
Signaling rate, each lane	DR _{PL}	Gb/s	25.78125 ±100 ppm			1
Four Lane Wavelength Range	λ1	nm	1294.53	1295.56	1296.59	
	λ2		1299.02	1300.05	1301.09	
	λ3		1303.54	1304.58	1305.63	
	λ4		1308.09	1309.14	1310.19	
Total launch power	P _{out}	dBm	-	-	10.5	
Average launch power, each lane	P _{avg}	dBm	-4.3	-	4.5	
Optical modulation amplitude, each lane (OMA)	OMA	dBm	-1.3	-	4.5	
Extinction ratio	ER	dB	4	-	-	
Side-mode suppression ratio	SMSR	dB	30	-	-	
Average launch power of OFF transmitter, per lane	P _{OFF}	dBm	-	-	-30	
Relative Intensity Noise	RIN	dB/Hz			-130	
Optical return loss tolerance	ORLT	dB	-	-	20	
Transmitter reflectance	TR	dB	-	-	-12	
Transmitter eye mask {X1, X2, X3, Y1, Y2, Y3}	M _t		{0.25, 0.4, 0.45, 0.25, 0.28, 0.4}			1
Receiver						
Receive Rate for Each Lane	DR _{PL}	Gb/s	25.78125 ±100 ppm			
Four Lane Wavelength Range	λ1	nm	1294.53	1295.56	1296.59	
	λ2		1299.02	1300.05	1301.09	
	λ3		1303.54	1304.58	1305.63	
	λ4		1308.09	1309.14	1310.19	
Overload Input Optical Power	P _{max}	dBm	5.5	-	-	
Average Receive Power for Each Lane	P _{in}	dBm	-10.6	-	4.5	2
Receiver sensitivity (OMA), each lane	P _{sens1}	dBm	-	-	-8.6	
Return Loss	RL	dB	-26	-	-	
Los De-Assert	P _d	dBm	-	-	-11.6	
Los Assert	P _a	dBm	-23.6	-	-	
Loss Hysteresis	P _d -P _a	dBm	0.5		6	

Notes:

1. Hit ratio 5×10^{-5} .
2. Measured with a PRBS $2^{31}-1$ test pattern, @25.78Gb/s, BER < 10^{-12} .

Pin Description

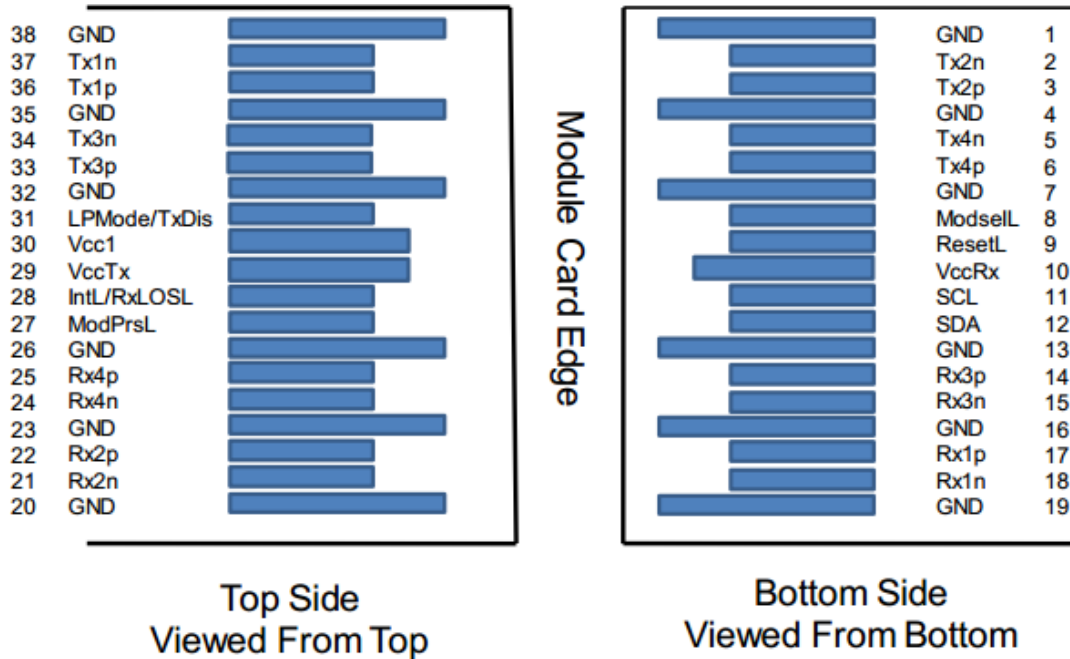

Pin	Name	Logic	Description	Notes
1	GND		Ground	1
2	Tx2n	CML-I	Transmitter Inverted Data Input	
3	Tx2p	CML-I	Transmitter Non-Inverted Data Input	
4	GND		Ground	1
5	Tx4n	CML-I	Transmitter Inverted Data Input	
6	Tx4p	CML-I	Transmitter Non-Inverted Data Input	
7	GND		Ground	1
8	ModSelL	LVTTL-I	Module Select	
9	ResetL	LVTTL-I	Module Reset	
10	Vcc Rx		+3.3V Power Supply Receiver	2
11	SCL	LVC MOS-I/O	2-wire serial interface clock	
12	SDA	LVC MOS-I/O	2-wire serial interface data	
13	GND		Ground	1
14	Rx3p	CML-O	Receiver Non-Inverted Data Output	
15	Rx3n	CML-O	Receiver Inverted Data Output	
16	GND		Ground	1
17	Rx1p	CML-O	Receiver Non-Inverted Data Output	
18	Rx1n	CML-O	Receiver Inverted Data Output	

Pin	Name	Logic	Description	Notes
19	GND		Ground	1
20	GND		Ground	1
21	Rx2n	CML-O	Receiver Inverted Data Output	
22	Rx2p	CML-O	Receiver Non-Inverted Data Output	
23	GND		Ground	1
24	Rx4n	CML-O	Receiver Inverted Data Output	
25	Rx4p	CML-O	Receiver Non-Inverted Data Output	
26	GND		Ground	1
27	ModPrsL	LVTTL-O	Module Present	
28	IntL/RxLOS L	LVTTL-O	Interrupt. Optionally configurable as RxLOSL via the management interface (SFF-8636)	
29	Vcc Tx		+3.3V Power supply transmitter	2
30	Vcc1		+3.3V Power supply	2
31	LPMoDe/TxD is	LVTTL-I	Low Power Mode. Optionally configurable as TxDis via the management interface (SFF-8636).	
32	GND		Ground	1
33	Tx3p	CML-I	Transmitter Non-Inverted Data Input	
34	Tx3n	CML-I	Transmitter Inverted Data Input	
35	GND		Ground	1
36	Tx1p	CML-I	Transmitter Non-Inverted Data	
37	Tx1n	CML-I	Transmitter Inverted Data Input	
38	GND		Ground	1

Notes:

1: GND is the symbol for signal and supply (power) common for the module. All are common within the module and all module voltages are referenced to this potential unless otherwise noted. Connect these directly to the host board signal-common ground plane.

2: VccRx, Vcc1 and VccTx are applied concurrently and may be internally connected within the module in any combination. Vcc contacts in SFF-8662 and SFF-8672 each have a steady state current rating of 1 A.

Recommended Power Supply Filter

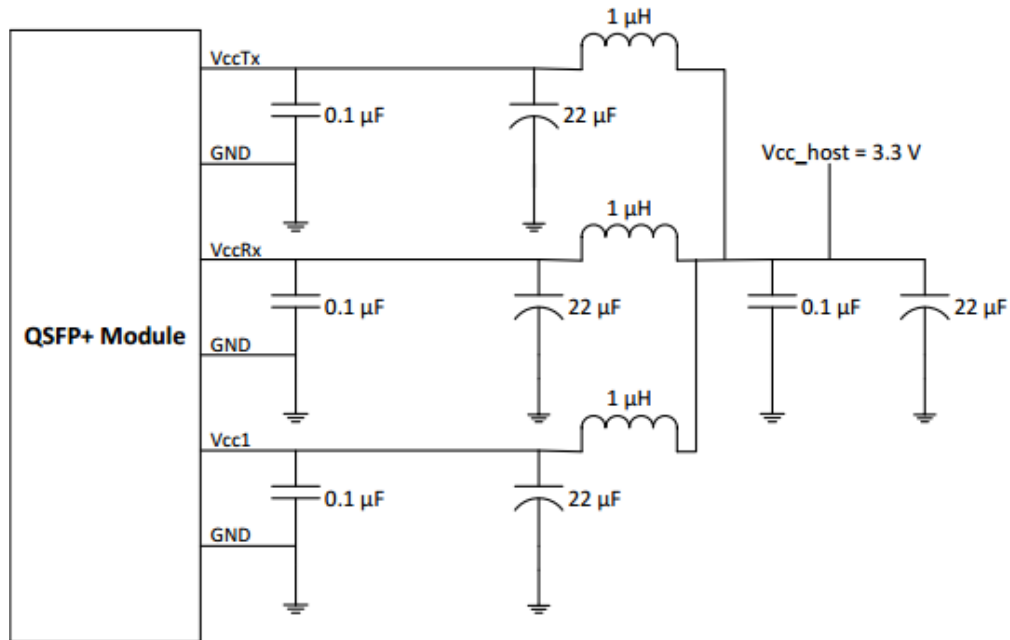

Package Dimensions

