

DATA SHEET
**UNIVISO – UMS10E4C-XX
10 Gigabit CWDM 40km SFP+ Transceiver**
UMS10E4C-XX Overview

UNIVISO's UMS10E4C-XX SFP+ optical transceivers are based on 10G Ethernet and SFF-8431 standard, and provide a quick and reliable interface for the 10G Ethernet application. They are available in 8 different CWDM wavelengths, from 1470nm to 1610nm. The digital diagnostics functions are available via the 2-wire serial bus, as specified in SFF-8472.

Product Features

- Up to 11.3 Gb/s bi-directional data links
- Compliant with IEEE 802.3ae 10GBASE-ER/EW
- Compliant with 10GFC
- Compliant with SFF-8431
- Hot-pluggable SFP+ footprint
- Temperature-stabilized EML laser in CWDM wavelength
- Duplex LC connector
- Built-in digital diagnostic functions
- Up to 40km on SMF
- Single power supply 3.3V
- RoHS Compliant
- Operating temperature range: 0°C to 70°C

Applications

- 10GBASE-ER/EW Ethernet
- 10GFC

Ordering Information

Part Number	Description
UMS10E4C-47	10 Gigabit CWDM SFP+ Transceiver, LC Connectors, 1470nm, Single Mode Fiber 40km
UMS10E4C-49	10 Gigabit CWDM SFP+ Transceiver, LC Connectors, 1490nm, Single Mode Fiber 40km
UMS10E4C-51	10 Gigabit CWDM SFP+ Transceiver, LC Connectors, 1510nm, Single Mode Fiber 40km
UMS10E4C-53	10 Gigabit CWDM SFP+ Transceiver, LC Connectors, 1530nm, Single Mode Fiber 40km
UMS10E4C-55	10 Gigabit CWDM SFP+ Transceiver, LC Connectors, 1550nm, Single Mode Fiber 40km
UMS10E4C-57	10 Gigabit CWDM SFP+ Transceiver, LC Connectors, 1570nm, Single Mode Fiber 40km
UMS10E4C-59	10 Gigabit CWDM SFP+ Transceiver, LC Connectors, 1590nm, Single Mode Fiber 40km
UMS10E4C-61	10 Gigabit CWDM SFP+ Transceiver, LC Connectors, 1610nm, Single Mode Fiber 40km

General Specifications

Parameter	Symbol	Min	Typ	Max	Unit	Remarks
Data Rate	DR	1.2		11.3	Gb/s	1
Bit Error Rate	BER			10 ⁻¹²		
Operating Temperature	T _{OP}	0		70	°C	2
Storage Temperature	T _{STO}	- 40		85	°C	3
Supply Current	I _S		400	450	mA	4
Input Voltage	V _{CC}	3.14	3.3	3.46	V	
Maximum Voltage	V _{MAX}	- 0.5		4	V	4

Notes:

1. IEEE 802.3ae
2. Case temperature
3. Ambient temperature
4. For electrical power interface

Link Distances

Parameter	Fiber Type	Distance Range (km)
1.2 – 11.3 Gb/s	9/125um SMF	40

Optical Characteristics – Transmitter
V_{CC}=3.14V to 3.46V, T_C=0°C to 70°C

Parameter	Symbol	Min	Typ	Max	Unit	Remarks
Optical Power	P _{OUT}	- 4		4	dBm	1
Optical Center Wavelength – 1470nm	λ _C	1465	1471	1477	nm	
Optical Center Wavelength – 1490nm		1485	1491	1497	nm	
Optical Center Wavelength – 1510nm		1505	1511	1517	nm	
Optical Center Wavelength – 1530nm		1525	1531	1537	nm	
Optical Center Wavelength – 1550nm		1545	1551	1557	nm	
Optical Center Wavelength – 1570nm		1565	1571	1577	nm	
Optical Center Wavelength – 1590nm		1585	1591	1597	nm	
Optical Center Wavelength – 1610nm		1605	1611	1617	nm	
Optical Modulation Amplitude	OMA	- 5.2				2
Extinction Ratio	ER	8.2			dB	
Spectral Width (- 20 dB)	Δλ			0.6	nm	
Side Mode Suppression Ratio	SMSR	30			dB	
Relative Intensity Noise	RIN			- 128	dB/Hz	
Transmitter Dispersion Penalty	TDP			2	dB	
Launch Power of OFF Transmitter	P _{OUT_OFF}			- 30	dBm	1

Transmitter Jitter

According to IEEE 802.3ae requirement

Notes:

1. Average
2. Per IEEE 802.3ae

Optical Characteristics – Receiver
V_{CC}=3.14V to 3.46V, T_C=0°C to 70°C

Parameter	Symbol	Min	Typ	Max	Unit	Remarks
Optical Center Wavelength	λ_C	1260		1620	nm	
Optical Input Power	P _{IN}	- 16		0.5	dBm	1
Receiver Sensitivity (OMA)@ 10.3Gb/s	R _{X_SEN1}			- 14.1	dBm	2
Stressed Receiver Sensitivity in OMA@ 10.3Gb/s	P _{SENS2}			- 11.3	dBm	3
Receiver Reflectance	T _{R_RX}			- 27	dB	
LOS Assert	LOS _A	- 25			dBm	
LOS De-Assert	LOS _D			- 18	dBm	
LOS Hysteresis		0.5			dB	

Notes:

1. Average, Informative
2. Measured with worst ER: BER<10⁻¹² 2³¹-1 PRBS
3. IEEE 802.3ae

Electrical Characteristics – Transmitter
V_{CC}=3.14V to 3.46V, T_C=0°C to 70°C

Parameter	Symbol	Min	Typ	Max	Unit	Remarks
Input differential impedance	R _{IN}		100		Ω	
Differential data input swing	V _{IN_PP}	120		850	mV	
Transmit disable voltage	V _D	2		V _{CC}	V	
Transmit enable voltage	V _{EN}	V _{EE}		V _{EE} +0.8	V	

Electrical Characteristics – Receiver
V_{CC}=3.14V to 3.46V, T_C=0°C to 70°C

Parameter	Symbol	Min	Typ	Max	Unit	Remarks
Differential data output swing	V _{OUT_PP}	300		850	mV	
Data output rise time (20%-80%)	T _R		30		ps	
Data output fall time (20%-80%)	T _F		30		ps	
LOS Fault	V _{LOS_Fault}	2		V _{CC_HOST}	V	
LOS Normal	V _{LOS_Normal}	V _{EE}		V _{EE} +0.5	V	

Digital Diagnostic Functions

SFP10-CWDM-ER-xxxx-D10 support the 2-wire serial communication protocol as defined in the SFF-8472. Digital diagnostic

information is accessible over the 2-wire interface at the address 0xA2. Digital diagnostics for SFP10-CWDM-ER-xxxx-D10 are internally calibrated by default. A micro controller unit inside the transceiver gathers the monitoring information and reports the status of transceiver.

Transceiver Temperature, internally measured, represented as a 16 bit signed twos complement value in increments of 1/256 degrees Celsius, Temperature accuracy is better than ±3 degrees Celsius over specified operating temperature and voltage.

Transceiver Supply Power, internally measured, represented as a 16 bit unsigned integer with the voltage defined as the full 16 bit value (0 – 65535) with LSB equal to 100 µVolt, yielding a total range of 0 to +6.55 Volts.

Transceiver TX bias current, internally measured, represented as a 16 bit unsigned integer with the current defined as the full 16 bit value (0 – 65535) with LSB equal to 2 µA, yielding a total range of 0 to 131mA. Accuracy is better than ±10% over specified operating temperature and voltage.

Transceiver TX output power, internally measured, represented as a 16 bit unsigned integer with the power defined as the full 16 bit value (0 – 65535) with LSB equal to 0.1 µW. Data is assumed to be based on measurement of laser monitor photodiode current. Accuracy is better than ±3dB over specified temperature and voltage. Data is not valid when the transmitter is disabled.

Transceiver RX received optical power, internally measured, represented as a 16 bit unsigned integer with the power defined as the full 16 bit 35 value (0 – 65535) with LSB equal to 0.1 µW. Accuracy is better than ±3dB over specified temperature and voltage.

Block Diagram of Transceiver

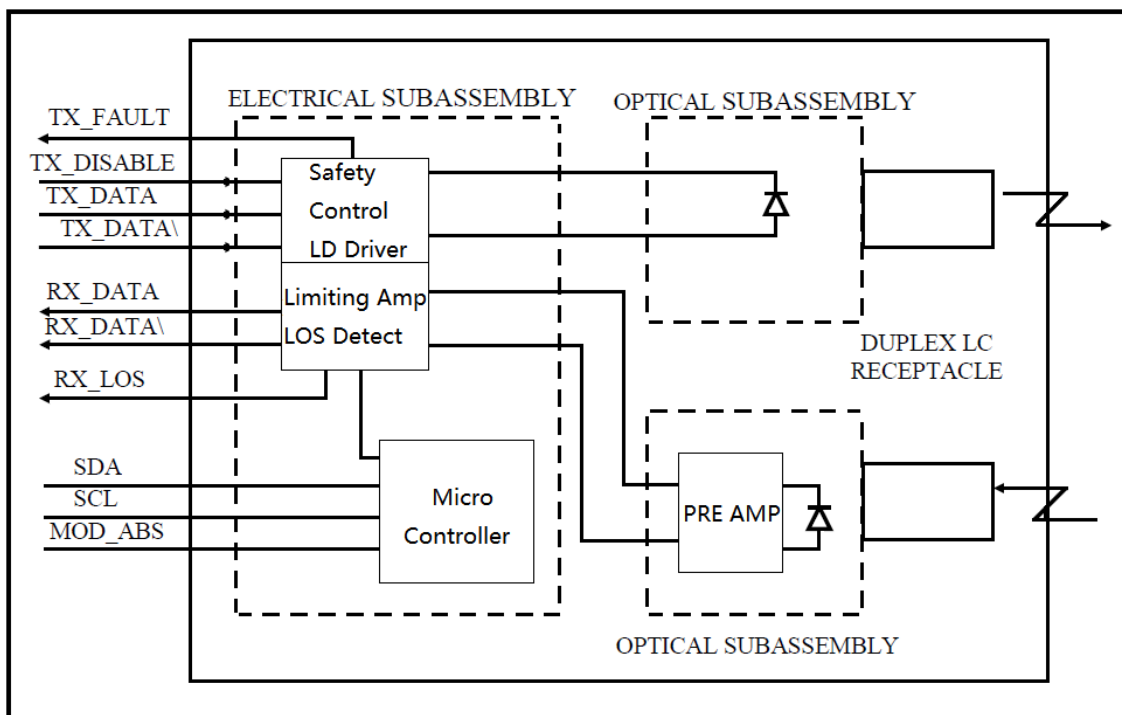

Transmitter Section

The Laser driver accepts differential input data and provide bias and modulation currents for driving a laser. An automatic power-control (APC) feedback loop is incorporated to maintain a constant average optical power. CWDM DFB in an eye safe optical subassembly (OSA) mates to the fiber cable.

TX_DISABLE

The TX_DISABLE signal is high (TTL logic "1") to turn off the laser output. The laser will turn on within 1ms when TX_DISABLE is low (TTL logic "0").

TX_FAULT

When the TX_FAULT signal is high, output indicates a laser fault of some kind. Low indicates normal operation.

Receiver Section

The receiver utilizes a PIN detector integrated with a trans-impedance preamplifier in an OSA. This OSA is connected to a Limiting Amplifier which providing post-amplification quantization, and optical signal detection. The limiting Amplifier is AC-coupled to the transimpedance amplifier, with internal 100Ω differential termination.

Receive Loss (RX_LOS)

The RX_LOS is high (logic "1") when there is no incoming light from the companion transceiver. This signal is normally used by the system for the diagnostic purpose. The signal is operated in TTL level.

Controller Section

The micro controller unit monitors the operation information of LD driver and Limiting Amplifier. And report these status to the customer.

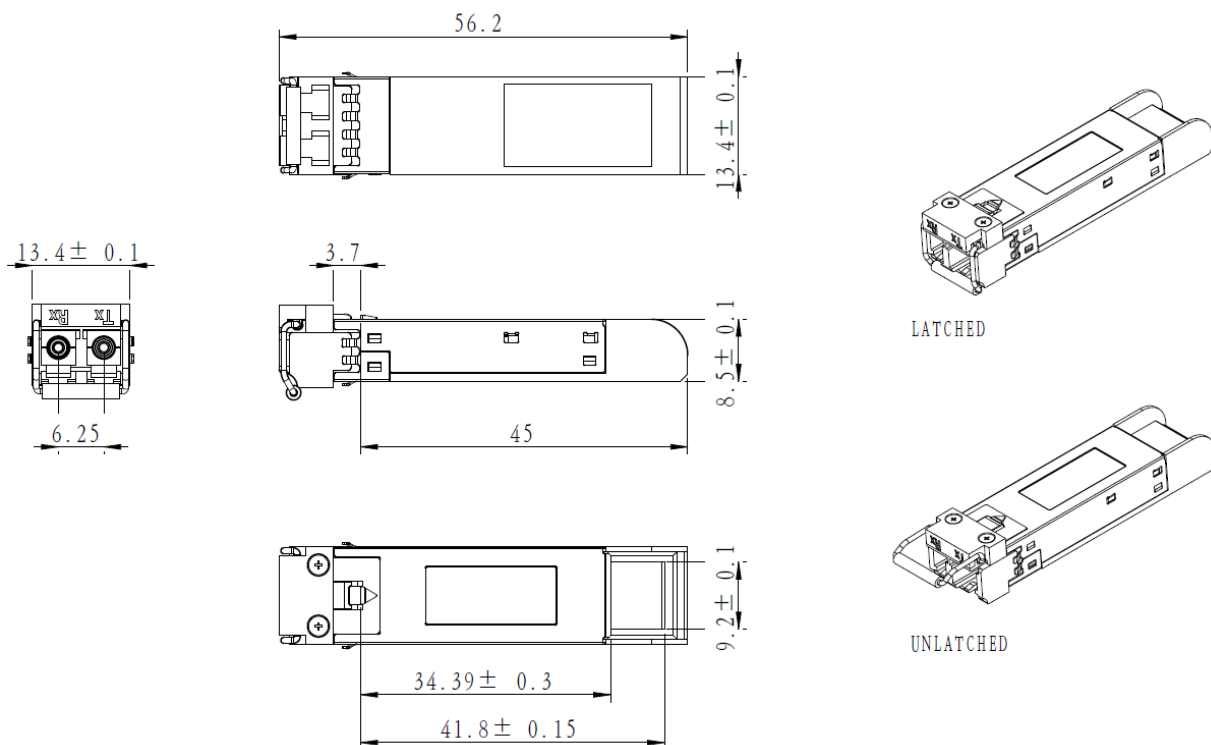
Dimensions

ALL DIMENSIONS ARE ±0.2mm UNLESS OTHERWISE SPECIFIED

UNIT: mm

Electrical Pad Layout

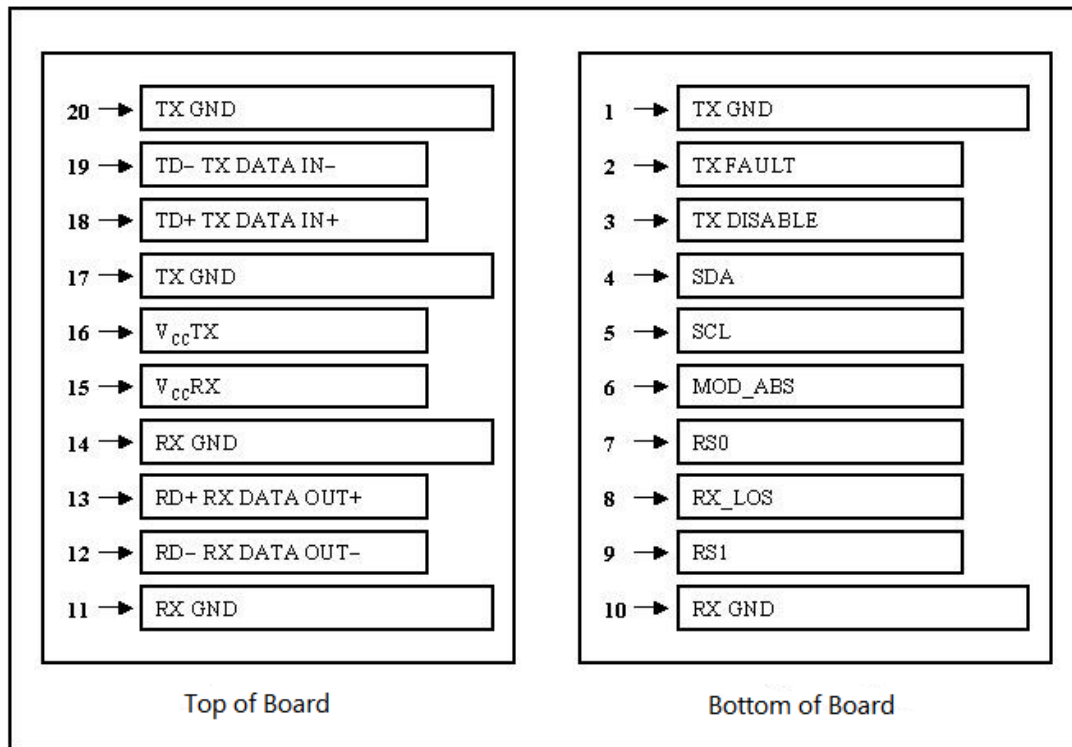
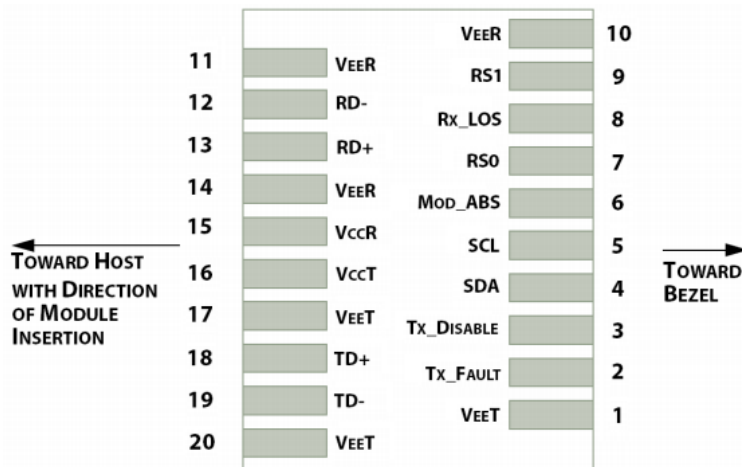

Pin Assignment

PIN #	Symbol	Description	Remarks
1	V _{EET}	Transmitter ground (common with receiver ground)	1
2	T _{FAULT}	Transmitter Fault.	
3	T _{DIS}	Transmitter Disable. Laser output disabled on high or open	2
4	SDA	Data line for serial ID	3
5	SCL	Clock line for serial ID	3

6	MOD_ABS	Module Absent. Grounded within the module	3
7	RS0	No connection required	
8	LOS	Loss of Signal indication. Logic 0 indicates normal operation	4
9	RS1	No connection required	1
10	V _{EER}	Receiver ground (common with transmitter ground)	1
11	V _{EER}	Receiver ground (common with transmitter ground)	1
12	RD-	Receiver Inverted DATA out. AC coupled	
13	RD+	Receiver Non-inverted DATA out. AC coupled	
14	V _{EER}	Receiver ground (common with transmitter ground)	1
15	V _{CCR}	Receiver power supply	
16	V _{CCT}	Transmitter power supply	
17	V _{EET}	Transmitter ground (common with receiver ground)	1
18	TD+	Transmitter Non-Inverted DATA in. AC coupled	
19	TD-	Transmitter Inverted DATA in. AC coupled	
20	V _{EET}	Transmitter ground (common with receiver ground)	1

Notes:

1. Circuit ground is isolated from chassis ground
2. Disabled: T_{DIS}>2V or open, Enabled: T_{DIS}<0.8V
3. Should Be pulled up with 4.7k – 10k ohm on host board to a voltage between 2V and 3.6V
4. LOS is open collector output

References

1. IEEE standard 802.3ae. IEEE Standard Department, 2005.
2. Enhanced 8.5 and 10 Gigabit Small Form Factor Pluggable Module "SFP+" – SFF-8431
3. Digital Diagnostics Monitoring Interface for Optical Transceivers – SFF-8472.