

DATA SHEET
**UNIVISO –UGS10E4D-xx
10G SFP+ (Small Form Pluggable) 40km Single Mode Transceiver**
SFP+ 10G-ER-DWDM-40KM Overview

UNIVISO's SFP+ 10G-ER-DWDM-40KM SFP+ transceivers are Enhanced Small Form Factor Pluggable SFP+ transceivers designed for use in 10-Gigabit multi-rate links up to 40km of G.652 single mode fiber. They are compliant with SFF-8431, SFF-8432 and 10GBASE ER/EW; support 4x, 8x and 10x Fibre Channel. Digital diagnostics functions are available via a 2-wire serial interface, as specified in SFF-8472.

The transceivers are RoHS compliant per Directive 2011/65/EU. The high performance cooled C band DWDM EML transmitter and high sensitivity PIN receiver provide superior performance for Ethernet applications at up to 40km links.

Product Features

- Up to 10Gb/s data links
- Duplex LC connector
- Hot-pluggable SFP footprint
- 100GHz ITU Grid, C Band DWDM EML laser transmitter
- Compliant with SFF-8431 SFF-8432 and IEE802.3ae
- Single power supply 3.3V
- RoHS-6 compliant (lead-free)
- 40km link length
- Operating temperature range (Case Temperature) : C Grade 0°C to 70°C
I Grade –40°C to 85°C

Applications

- 10GBASE-ER/EW Ethernet
- 10G Fibre Channel
- SONET OC-192/SDH STM-64
- DWDM Networks

Ordering Information

Part Number	Description
UGS10E4D-xx	10 Gigabit DWDM SFP+ Transceiver, Single Mode Fiber 40km (ITU 100GHz Grid); 0°C to 70°C
UGS10E4DI-xx	10 Gigabit DWDM SFP+ Transceiver, Single Mode Fiber 40km (ITU 100GHz Grid); –40°C to 85°C

For More Information:

UNIVISO TECHNOLOGIES& DEVELOP LIMITED

Room 608, Yuanzheng Building B, Nanshan District, Shenzhen, China, 518052

General Specifications

Parameter	Symbol	Min	Typ	Max	Unit	Remarks
Data Rate	DR	8		10.31	Gb/s	
Bit Error Rate	BER			10 ⁻¹²		
Operating Temperature	T _{OP}	0		70	°C	1
Storage Temperature	T _{STO}	- 40		85	°C	2
Supply Current	I _S		195	450	mA	3
Input Voltage	V _{CC}	3.14	3.3	3.46	V	
Maximum Voltage	V _{MAX}	- 0.5		4	V	3

Notes:

1. Case temperature
2. Ambient temperature
3. For electrical power interface

Optical Characteristics – Transmitter
V_{CC}=3.14V to 3.46V, T_C=0°C to 70°C

Parameter	Symbol	Min	Typ	Max	Unit	Remarks
Output Optical Power	P _{TX}	-1		5	dBm	1
Optical Center Wavelength	λ _c		As per ITU-T 694.1		nm	2
Extinction Ratio	ER	7			dB	
Side Mode Suppression Ratio	SMSR	30			dB	
Laser Off Power	P _{off}			-30	dBm	
Relative Intensity Noise	RIN			- 128	dB/Hz	3
Output Eye	Compliant with IEEE802.3 z (class 1 laser safety)					

Notes:

1. Average power figures are informative only, per IEEE802.3ae.
2. Refer to ITU-T 694.1 table.
3. 12dB reflection.

ITU-T 694.1 Table

ITU Number	Central Wavelength(nm) C band	Frequency (THZ)
61	1528.77	196.1
60	1529.55	196
59	1530.33	195.9
58	1531.12	195.8
57	1531.90	195.7
56	1532.68	195.6
55	1533.47	195.5
54	1534.25	195.4

53	1535.04	195.3
52	1535.82	195.2
51	1536.61	195.1
50	1537.40	195
49	1538.19	194.9
48	1538.98	194.8
47	1539.77	194.7
46	1540.56	194.6
45	1541.35	194.5
44	1542.14	194.4
43	1542.94	194.3
42	1543.73	194.2
41	1544.53	194.1
40	1545.32	194
39	1546.12	193.9
38	1546.92	193.8
37	1547.72	193.7
36	1548.51	193.6
35	1549.32	193.5
34	1550.12	193.4
33	1550.92	193.3
32	1551.72	193.2
31	1552.52	193.1
30	1553.33	193
29	1554.13	192.9
28	1554.94	192.8
27	1555.75	192.7
26	1556.55	192.6
25	1557.36	192.5
24	1558.17	192.4
23	1558.98	192.3
22	1559.79	192.2
21	1560.61	192.1
20	1561.42	192
19	1562.23	191.9
18	1563.05	191.8
17	1563.86	191.7

Optical Characteristics – Receiver
V_{CC}=3.14V to 3.46V, T_C=0°C to 70°C

Parameter	Symbol	Min	Typ	Max	Unit	Remarks
Optical Center Wavelength	λ_C	1260		1620	nm	
Receiver Sensitivity	R _{X_SEN}			- 15	dBm	1,2
Receiver Overload	Pol	0.5			dBm	
LOS Assert	P _{LOS_A}	- 28			dBm	
LOS De-Assert	P _{LOS_D}			- 16	dBm	
LOS Hysteresis	LOS H	0.5			dB	

Notes:

1. Conditions of stressed receiver tests per IEEE802.3ae. CSRS testing requires the host board to be SFF-8431 compliant.
2. The receiver sensitivity over fiber may vary depending on the host's clock and data recovery model.

Electrical Characteristics – Transmitter
 $V_{CC}=3.14V$ to $3.46V$, $T_C=0^{\circ}C$ to $70^{\circ}C$

Parameter	Symbol	Min	Typ	Max	Unit	Remarks
Input differential impedance	R_{IN}		100		Ω	1
Single ended data input swing	V_{IN_PP}	180		700	mV	2
Transmit disable voltage	V_D	2		V_{CC}	V	3
Transmit enable voltage	V_{EN}	V_{EE}		$V_{EE}+0.8$	V	
Transmit disable assert time				10	us	

Electrical Characteristics – Receiver
 $V_{CC}=3.14V$ to $3.46V$, $T_C=0^{\circ}C$ to $70^{\circ}C$

Parameter	Symbol	Min	Typ	Max	Unit	Remarks
Rx Output Diff Voltage	V_{OUT_PP}	300		850	mV	3
Data output rise time	t_r	30			ps	4
Data output fall time	t_f	30			ps	4
LOS Fault	V_{LOS_Fault}	$V_{CC} - 0.5$		V_{CC_HOST}	V	5
LOS Normal	V_{LOS_Normal}	V_{EE}		$V_{EE} + 0.8$	V	5

Note:

1. Connected directly to TX data input pins. AC coupling from pins into laser driver IC.
2. Per SFF-8431 Rev 3.0
3. Into 100 ohms differential termination.
4. 20% ~ 80%
5. LOS is an open collector output. Should be pulled up with 4.7k – 10k Ω on the host board. Normal operation is logic 0; loss of signal is logic 1. Maximum pull-up voltage is 5.5V.

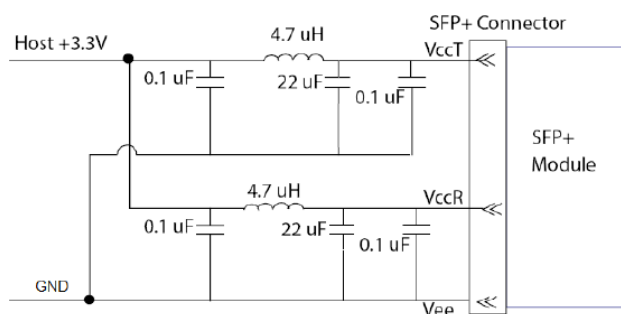
Recommended Circuit

Block Diagram of Transceiver

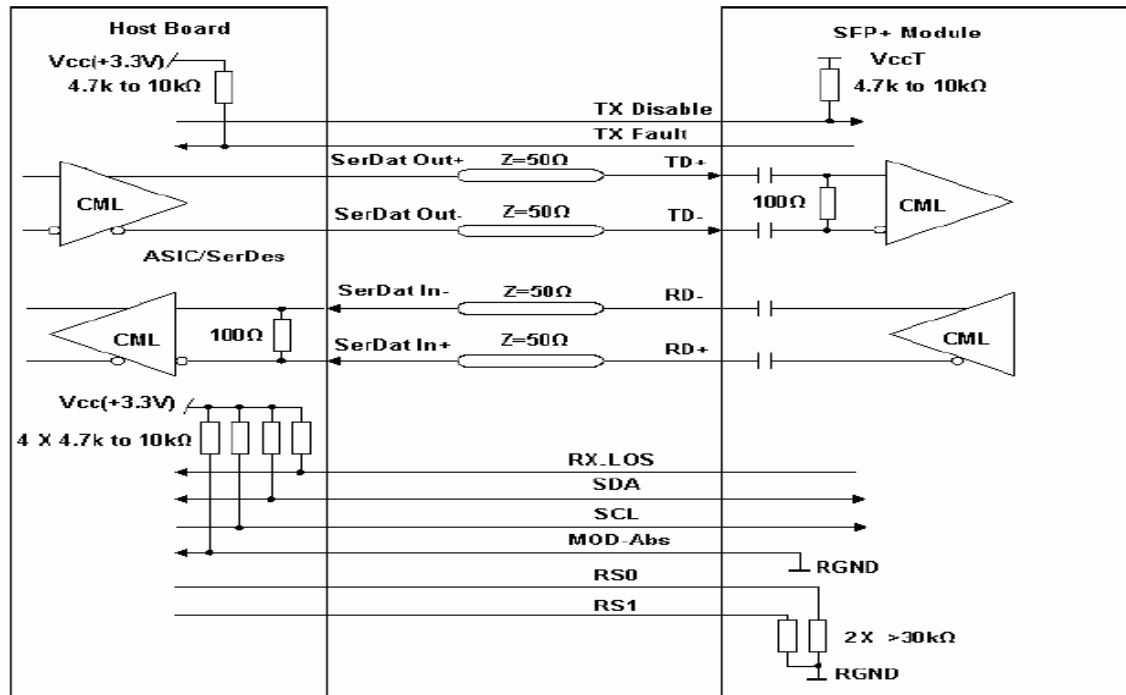

Transmitter Section

The EML driver accepts differential input data and provide bias and modulation currents for driving a laser. An automatic power-control (APC) feedback loop is incorporated to maintain a constant average optical power. 1550nm EML in an eye safe optical subassembly (OSA) mates to the fiber cable.

TX_DISABLE

The TX_DISABLE signal is high (TTL logic "1") to turn off the laser output. The laser will turn on within 1ms when TX_DISABLE is low (TTL logic "0").

TX_FAULT

When the TX_FAULT signal is high, output indicates a laser fault of some kind. Low indicates normal operation.

Receiver Section

The receiver utilizes a PIN detector integrated with a trans-impedance preamplifier in an OSA. This OSA is connected to a Limiting Amplifier which providing post-amplification quantization, and optical signal detection. The limiting Amplifier is AC-coupled to the transimpedance amplifier, with internal 100Ω differential termination.

Timing Parameters

Parameter	Symbol	Min	Typ	Max	Units	Ref.
Time to initialization stabilization	t_start_up			30	S	

General Specifications

Parameter	Symbol	Min	Typ	Max	Units	Ref.
Bit Rate	BR	8		10.31	Gb/s	
Max. Supported Link Length	L _{MAX}			40	KM	1

Notes: 1. Over G.652 single mode fiber.

Electrical Pad Layout

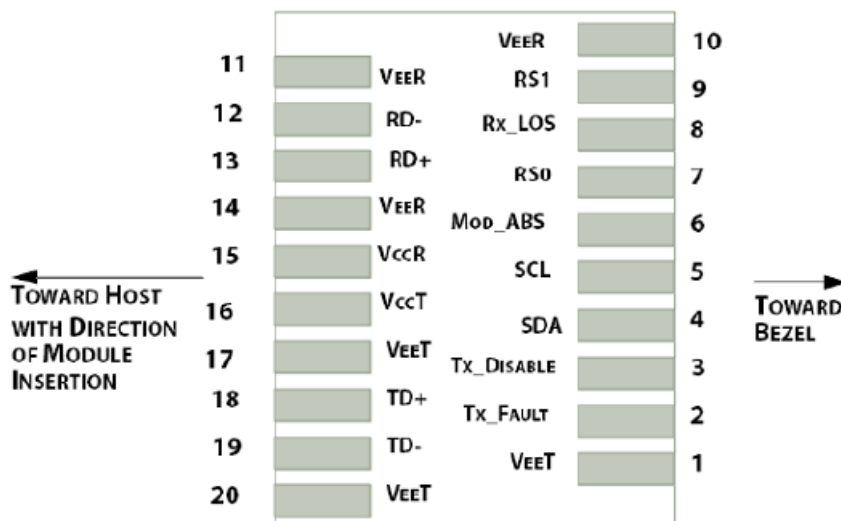

Pin Assignment

PIN #	Symbol	Description	Remarks
1	VeeT	Transmitter Ground	1
2	TX Fault	Transmitter Fault Indication	2
3	TX Disable	Transmitter Disable	3
4	SDL	2 wire serial interface data input/output (SDA)	
5	SCL	2 wire serial interface clock input (SCL)	
6	MOD-ABS	Module Absent, connect to VeeR or VeeT in the module	2
7	RS0	Rate select0, optionally control SFP+ receiver. When high, input data rate >4.5Gb/s; when low, input data rate <=4.5Gb/s	
8	LOS	Loss of Signal	4
9	RS1	Rate select0, optionally control SFP+ transmitter. When high, input data rate >4.5Gb/s; when low, input data rate <=4.5Gb/s	
10	VeeR	Receiver Ground	1
11	VeeR	Receiver Ground	1
12	RD-	Inv. Received Data Out	
13	RD+	Received Data Out	
14	VeeR	Receiver Ground	1
15	VccR	Receiver Power	
16	VccT	Transmitter Power	
17	VeeT	Transmitter Ground	1
18	TD+	Transmit Data In	
19	TD-	Inv. Transmit In	

Notes:

1. The module ground pins shall be isolated from the module case.
2. This pin is an open collector/drain output pin and shall be pulled up with 4.7K-10Kohms to Host_Vcc on the host board.
3. This pin shall be pulled up with 4.7K-10Kohms to VccT in the module.
4. This pin is an open collector/drain output pin and shall be pulled up with 4.7K-10Kohms to Host_Vcc on the host board.

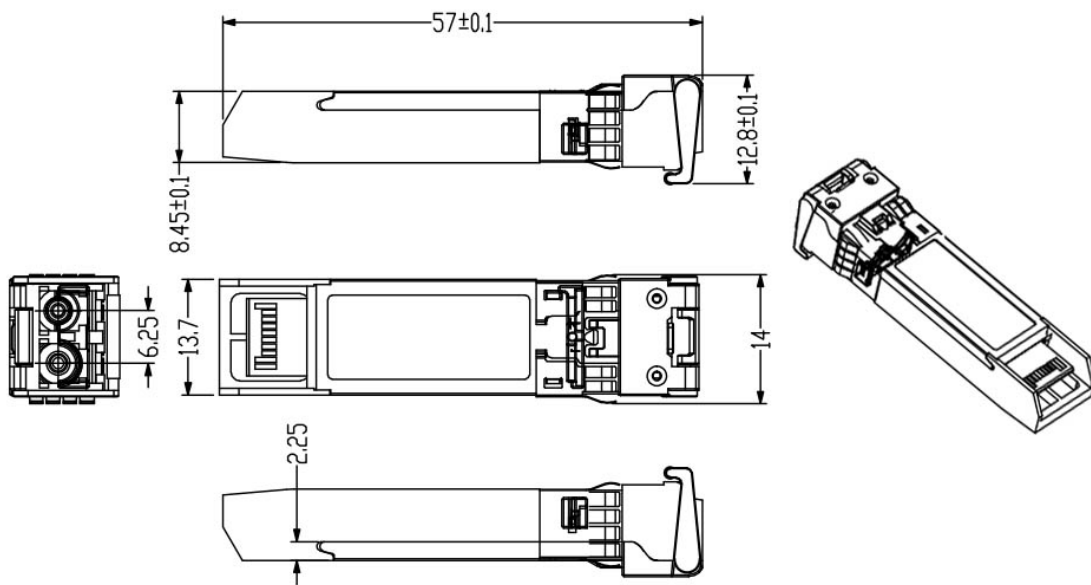
Dimensions

**ALL DIMENSIONS ARE ±0.2mm UNLESS OTHERWISE SPECIFIED
UNIT: mm**

References

1. IEEE standard 802.3. IEEE Standard Department, 2005.
2. Small Form Factor Pluggable (SFP) Transceiver Multi-Source Agreement (MSA), September 2000.