

DATA SHEET

Product Specification

1.25GBase-DWDM SFP Transceiver(SMF,C-Band ,80KM,LC)

Features

- Up to 1.25Gbps Data Links
- Transceiver unit with independent DWDM DFB Laser diode transmitter PIN photodiode receiver
- Metal enclosure, for lower EMI
- Single +3.3V power supply
- 100GHz ITU Grid, C Band
- Duplex LC/UPC type pluggable optical interface
- Operating temperature range:
Commercial: -5°C~+70°C
- RoHS Compliant
- Wavelength controlled within $\pm 0.1\text{nm}$ over life and temperature
- Digital diagnostic monitoring
- 80 km with 9/125 μm single mode fiber (SMF) of maximum interconnect distances
- Low power dissipation

Application

- C Band DWDM networks
- SONET/SDH networks
- Fiber channel
- Gigabit Ethernet

Standard

- Compliant with SFF-8472
- Compliant with DWDM SFP MSA

Product Description

UNIVISO UTS01ZRD-XX Small Form Factor Pluggable (SFP) transceivers are compatible with the Small Form Factor Pluggable Multi-Sourcing Agreement (MSA) and SFF-8472. The transceiver consists of five sections: the LD driver, the limiting amplifier, the digital diagnostic monitor, the DFB laser and the PIN .The module data link up to 80KM in 9/125um single mode fiber. It offers a simple and convenient way to interface PCBs to single mode fiber optic cables in Dense Wavelength Division Multiplexing (DWDM) applications. It is a high performance, cost effective module for serial optical data communication applications.

The optical output can be disabled by a TTL logic high-level input of Tx Disable, and the system also can disable the module via I2C. Tx Fault is provided to indicate that degradation of the laser. Loss of signal (LOS) output is provided to indicate the loss of an input optical signal of receiver or the link status with partner. The system can also get the LOS (or Link)/Disable/Fault information via I2C register access.

Wavelength Selection

Channel	Wavelength (nm)	Frequency (THZ)	Channel	Wavelength (nm)	Frequency (THZ)
C17	1563.86	191.70	C39	1546.12	193.90
C18	1563.05	191.80	C40	1545.32	194.00
C19	1562.23	191.90	C41	1544.53	194.10
C20	1561.42	192.00	C42	1543.73	194.20
C21	1560.61	192.10	C43	1542.94	194.30
C22	1559.79	192.20	C44	1542.14	194.40
C23	1558.98	192.30	C45	1541.35	194.50
C24	1558.17	192.40	C46	1540.56	194.60
C25	1557.36	192.50	C47	1539.77	194.70
C26	1556.55	192.60	C48	1538.98	194.80
C27	1555.75	192.70	C49	1538.19	194.90
C28	1554.94	192.80	C50	1537.40	195.00
C29	1554.13	192.90	C51	1536.61	195.10
C30	1553.33	193.00	C52	1535.82	195.20
C31	1552.52	193.10	C53	1535.04	195.30
C32	1551.72	193.20	C54	1534.25	195.40
C33	1550.92	193.30	C55	1533.47	195.50
C34	1550.12	193.40	C56	1532.68	195.60
C35	1549.32	193.50	C57	1531.90	195.70
C36	1548.51	193.60	C58	1531.12	195.80
C37	1547.72	193.70	C59	1530.33	195.90
C38	1546.92	193.80	C60	1529.55	196.00

Non-ITU	Peak wavelength between 1528.77nm-1563.86	C61	1528.77	196.10
---------	--	-----	---------	--------

Specification

Absolute Maximum Ratings				
Parameter	Symbol	Min	Max	Unit
Storage temperature	TS	-40	85	°C
Power Supply Voltage	Vcc3	-0.5	+4	V
Relative Humidity	RH	5	95	%
Signal Input Voltage		-0.3	Vcc+0.3	V
Receiver Damage Threshold			+5	dBm

Recommended Operating Conditions					
Parameter	Symbol	Min	Typical	Max	Unit
Operating Case Temperature (Commercial)	Tc	-5		70	°C
Power Supply Voltage	Vcc3	3.13	3.3	3.47	V
Supply Current	Icc3			500	mA
Power Supply Noise Rejection				100	mVp-p
Data Rate			1.25		Gbps
Fiber Length 9/125µm core SMF		-	80	-	km

Electrical Characteristics						
Parameter	Symbol	Min	Typical	Max	Unit	Notes
Transmit Total Supply Current	Icc			A	mA	1
Transmit disable voltage	VIH	2		Vcc+0.3	V	
Transmit enable voltage	VIL	0		0.8	V	
Transmitter Fault Input-High	VDISL	2		Vcc+0.3	V	
Transmitter Fault Input-Low	VTxFH	0		0.8	V	
Receiver Total Supply Current	Icc			B	mA	1
LOS output high level	VLOS-H	2		Vcc+0.3	V	2
LOS output low level	VLOS-L	0		0.8	V	2

Notes:

- 1) A (TX) + B (RX) =500mA (Not include termination circuit).
- 2) Loss Of Signal is LVTTTL. Logic 0 indicates normal operation; logic 1 indicates no signal detected.

Optical transmitter Characteristics						
Parameter	Symbol	Min	Typical	Max	Unit	Notes
Launched Power (avg.)	P _{out}	0		4	dBm	3
Center Wavelength Spacing			100		GHz	
Operating Wavelength Range	λ_c	$\lambda-100$	λ	$\lambda+100$	nm	4
Spectral Width(-20dB)	$\Delta\lambda$			0.3	nm	
Side Mode Suppression Ratio	SMSR	30			dB	
Extinction Ratio	ER	9			dB	
Transmitter OFF Output Power	P _{off}			-45	dBm	
Differential Line Input Impedance	R _{IN}	90	100	110	Ohm	
Output Eye Diagram	Compliant with IEEE802.3ae eye mask					
Optical receiver Characteristics						
Parameter	Symbol	Min	Typical	Max	Unit	Notes
Receiver Sensitivity	S			-26	dBm	5
Wavelength Range	λ_c	1270		1610	nm	
Optical Power Input Overload	P _{in-max}	-3			dBm	
Receiver Damage Threshold				5	dBm	
LOS	Optical De-assert	P _d		-26	dBm	
	Optical Assert	P _a	-38			
LOS hysteresis		0.5	2	6	dB	

Notes:

- 3) Class 1 Laser Safety per FDA/CDRH and IEC-825-1 regulations.
- 4) “ λ ” specified ITU center wavelength, please the “Wavelength selection” .
- 5) Receiver Reflectance Measured with a PRBS 2²³-1 test pattern, @1250Mbps, ER=9dB, BER<10⁻¹².

Digital Diagnostic Monitoring Information

UNIVISO UTS01ZRD-XX transceivers support the 2-wire serial communication protocol as defined in the SFP MSA. It is very closely related to the EEPROM defined in the GBIC standard, with the same electrical specifications. The standard SFP serial ID provides access to identification information that describes the transceiver’s capabilities, standard interfaces, manufacturer, and other information.

Additionally, UNIVISO SFP transceivers provide a unique enhanced digital diagnostic monitoring interface, which allows real-time access to device operating parameters such as transceiver temperature, laser bias current, transmitted optical power, received optical power and transceiver supply voltage. It also defines a sophisticated system of alarm and warning flags, which alerts end-users when particular operating parameters are outside of a factory set normal range.

The SFP MSA defines a 256-byte memory map in EEPROM that is accessible over a 2-wire

serial interface at the 8 bit address 1010000X (A0h). The digital diagnostic monitoring interface makes use of the 8 bit address 1010001X (A2h), so the originally defined serial ID memory map remains unchanged. The interface is identical to, and is thus fully backward compatible with both the GBIC Specification and the SFP Multi Source Agreement.

The operating and diagnostics information is monitored and reported by a Digital Diagnostics Transceiver Controller (DDTC) inside the transceiver, which is accessed through a 2-wire serial interface. When the serial protocol is activated, the serial clock signal (SCL, Mod Def 1) is generated by the host. The positive edge clocks data into the SFP transceiver into those segments of the EEPROM that are not write-protected. The negative edge clocks data from the SFP transceiver. The serial data signal (SDA, Mod Def 2) is bi-directional for serial data transfer. The host uses SDA in conjunction with SCL to mark the start and end of serial protocol activation. The memories are organized as a series of 8-bit data words that can be addressed individually or sequentially.

Pin Descriptions

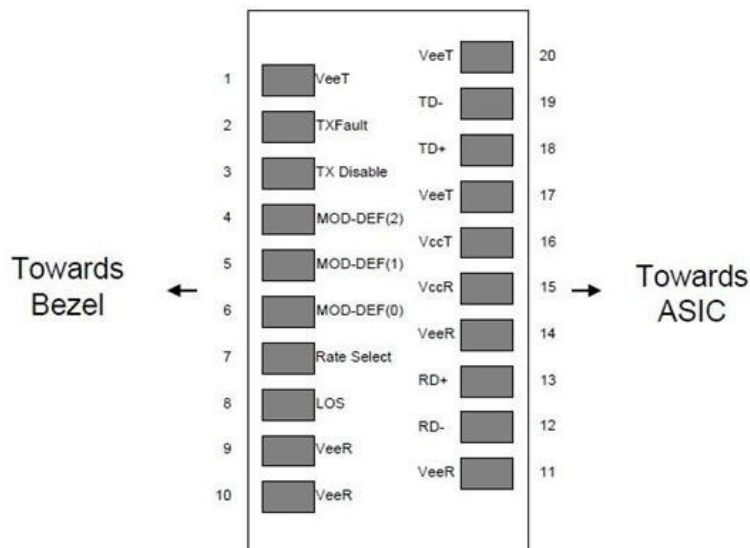

Diagram of Host Board Connector Block Pin Numbers and Name

Pin Assignment

Pin	Symbol	Description	Notes
1	VeeT	Transmitter Ground (Common with Receiver Ground)	1
2	TX_Fault	Transmitter Fault, Low: normal; High: abnormal	2
3	TX_Disable	Transmitter Disable High: Transmitter off Low: Transmitter on	3

4	MOD_DEF(2)	Module Definition 2. Data line for Serial ID.	3
5	MOD_DEF(1)	Module Definition 1. Clock line for Serial ID.	3
6	MOD_DEF(0)	Module Definition 0. Grounded within the module.	3
7	Rate Select	No connection required	4
8	LOS	Loss of Signal indication. Logic 0 indicates normal operation.	5
9	VEER	Receiver Ground(Common with Transmitter Ground)	1
10	VEER	Receiver Ground(Common with Transmitter Ground)	1
11	VEER	Receiver Ground(Common with Transmitter Ground)	1
12	RD-	Receiver Inverted DATA out. AC Coupled. CML-O	
13	RD+	Receiver Non-inverted DATA out. AC Coupled. CML-O	
14	VeeR	Receiver Ground	1
15	VccR	Receiver Power Supply	
16	VccT	Transmitter Power Supply	
17	VeeT	Transmitter Ground	1
18	TD+	Transmitter Non-Inverted DATA in. AC Coupled. CML-I	
19	TD-	Transmitter Inverted DATA in. AC Coupled. CML-I	
20	VeeT	Transmitter Ground (Common with Receiver Ground)	1

Notes:

- 1) Circuit ground is internally isolated from chassis ground.
- 2) TFAULT is an open collector/drain output, which should be pulled up with a 4.7k – 10k Ohms resistor on the host board if intended for use. Pull up voltage should be between 2.0V to Vcc + 0.3V. A high output indicates a transmitter fault caused by either the TX bias current or the TX output power exceeding the preset alarm thresholds. A low output indicates normal operation. In the low state, the output is pulled to <0.8V.
- 3) Laser output disabled on TDIS >2.0V or open, enabled on TDIS <0.8V.
- 4) This is an optional input used to control the receiver bandwidth for compatibility with multiple data rates (most likely Fiber Channel 1x and 2x Rates). If implemented, the input will be internally pulled down with > 30kΩ resistor. The input states are:
 - Low (0 – 0.8V): Reduced Bandwidth
 - (>0.8, < 2.0V): Undefined
 - High (2.0 – 3.465V): Full Bandwidth
- 5) LOS is open collector output. It should be pulled up with 4.7kΩ – 10kΩ on host board to a typical 3.3V voltage. Logic 0 indicates normal operation; logic 1 indicates loss of signal.

Package Outline

Dimensions are in millimeters. All dimensions are $\pm 0.2\text{mm}$ unless otherwise specified. (Unit: mm)

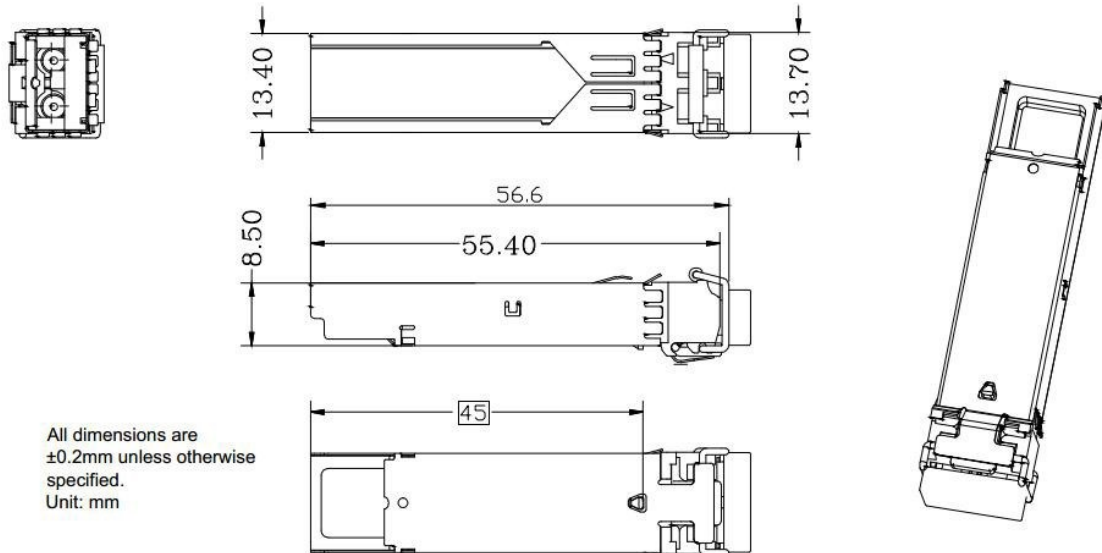

Regulatory Compliance

Feature	Test	Method
Electrostatic Discharge (ESD) to the Electrical Pins	MIL-STD-883E Method 3015.7	Class 1(>1000V for SFI pins, >2000Vfor other pins.)
Electrostatic Discharge (ESD) Immunity	IEC61000-4-2	Class 2(>4.0kV)
Electromagnetic Interference (EMI)	CISPR22 ITE Class B FCC Class B CENELEC EN55022 VCCI Class 1	Comply with standard
Immunity	IEC61000-4-3	Comply with standard
Eye Safety	FDA 21CFR 1040.10 and 1040.11 EN (IEC) 60825-1,2	Compatible with Class I laser Product

Ordering information

Part. No	Specifications								
	Pack	Rate (Gbps)	Tx (nm)	Po (dBm)	RX	Sen (dBm)	Temp (°C)	Reach (km)	DDM
UTS01ZRD-XX	SFP	1.25	DWDM DFB	0~4	PIN	<-26	-5~70	80	Y