

DATA SHEET

UMQ40L2L

40Gb/s QSFP+ LR4 Optical Transceiver

QSFP10-LR4-D12 Overview

UNIVISO's QSFP+ LR4 optical transceivers are based on Ethernet IEEE 802.3ba standard and SFF 8436 standard. The QSFP+ transceiver transmitter converts 4 input 10Gb/s electrical data paths to 4 CWDM optical paths and multiplexes them into a single 40Gb/s optical transmission. To the receiver, the module optically de-multiplexes a 40Gb/s input optical signal into 4 CWDM optical signals, and converts them to 4 output electrical data paths. The central wavelengths of the 4 CWDM channels are 1271, 1291, 1311 and 1331 nm.

Product Features

- Uncooled 4x10Gb/s CWDM transmitter
- Up to 10.3125Gbps data rate per wavelength
- QSFP+ MSA compliant
- Duplex LC connector
- Built-in digital diagnostic functions
- Up to 10km on SMF
- Maximum 2.5W power consumption
- RoHS Compliant
- Operating temperature range:0°C to 70°C
- XLPP electrical interface
- Anti-sulphuration

Applications

- 40G Ethernet

Ordering Information

Part Number	Description	Color on Clasp
UMQ40L2L	40G QSFP+ LR4 LC Connectors, Up to 10km on SMF, with DOM function, Anti-sulphuration	Blue

General Specifications

Parameter	Symbol	Min	Typ	Max	Unit	Remarks
Bit Error Rate	BER			10^{-12}		
Operating Temperature	T_C	0		70	°C	1
Storage Temperature	T_{STO}	-40		85	°C	2
Input Voltage	V_{CC}	3.14	3.3	3.46	V	
Maximum Supply Voltage	V_{MAX}	-0.5		3.6	V	3

Notes:

1. Case temperature
2. Environment temperature
3. Electrical interface

Link Distances

Data Rate	Fiber Type	Link length supported (km)
40 Gb/s	50/125um OM3 MMF	0.15
40 Gb/s	50/125um OM4 MMF	0.15
40 Gb/s	9/125um SMF	10

Optical – Characteristics – Transmitter

Parameter	Symbol	Min	Typ	Max	Unit	Remarks
Total Average Launch Power	P_{OUT}			8.3	dBm	
Average Launch Power per Lane	TXP_x	-7		2.3	dBm	
Optical Center Wavelength(L0 Lane)	λ_c	1264.5	1271	1277.5	nm	
Optical Center Wavelength(L1 Lane)	λ_c	1284.5	1291	1297.5	nm	
Optical Center Wavelength(L2 Lane)	λ_c	1304.5	1311	1317.5	nm	
Optical Center Wavelength(L3 Lane)	λ_c	1324.5	1331	1337.5	nm	
Optical Modulation Amplitude	OMA	-4		3.5	dBm	
Extinction Ratio	ER	3.5	5.0		dB	
Side Mode Suppression Ratio	SMSR	30			dB	
Relative Intensity Noise	RIN			-128	dB/Hz	
Transmitter Dispersion Penalty	TDP			2.6	dB	
Optical Return Loss Tolerance	TOL			20	dB	
Transmitter eye mask definition	Compliant with IEEE 802.3ba standard					
Average launch power of OFF transmitter, per lane				-30	dBm	

Optical – Characteristics – Receiver

Parameter	Symbol	Min	Typ	Max	Unit	Remarks
Optical Center Wavelength (L0 Lane)	λ_c	1264.5	1271	1277.5	nm	
Optical Center Wavelength (L1 Lane)	λ_c	1284.5	1291	1297.5	nm	
Optical Center Wavelength (L2 Lane)	λ_c	1304.5	1311	1317.5	nm	
Optical Center Wavelength (L3 Lane)	λ_c	1324.5	1331	1337.5	nm	
Average Receive Power per Lane	RXP_x	-13.7		2.3	dBm	
Damage Threshold per Lane	P_{MAX}	3.4			dBm	
Receiver Sensitivity (OMA) per Lane	RX_{sens}		-14.0	-11.5	dBm	
Return Loss	RL			-26	dB	
LOS Assert	LOS_A	-28			dBm	1
LOS De-Assert	LOS_D			-15	dBm	1
LOS Hysteresis	LOS_H	1	3		dB	

Notes:

1. Average receive power.

Electrical – Characteristics – Transmitter

Parameter	Symbol	Min	Typ	Max	Unit	Remarks
Input differential impedance	R_{IN}		100		Ω	
Differential data input swing	V_{IN_PP}	120		1200	mV	
Transmitter Disable Voltage	V_{DIS}	$V_{CC}-1.3$		V_{CC}	V	
Transmitter Enable Voltage	V_{EN}	V_{EE}		$V_{EE}+0.8$	V	

Electrical – Characteristics – Receiver

Parameter	Symbol	Min	Typ	Max	Unit	Remarks
Differential data output swing	V_{OUT_PP}	200		400	mV	1, 2
		300		600	mV	
		400	550	800	mV	
		600		1200	mV	
Data output rise/fall time (20%-80%)	t_r/t_f	28			ps	
LOS Fault Voltage	V_{LOS_A}	$V_{CC}-1.3$		V_{CC_HOST}	V	
LOS Normal	V_{LOS_D}	V_{EE}		$V_{EE}+0.5$	V	

Notes:

1. AC coupled with 100 Ω differential output impedance.
2. Output voltage is settable in 4 discrete steps via I2C. Default is 400 - 800 mV.

TX1-TX4 Typical Eye Pattern

Test Condition: 30°C, BIAS=32-38mA

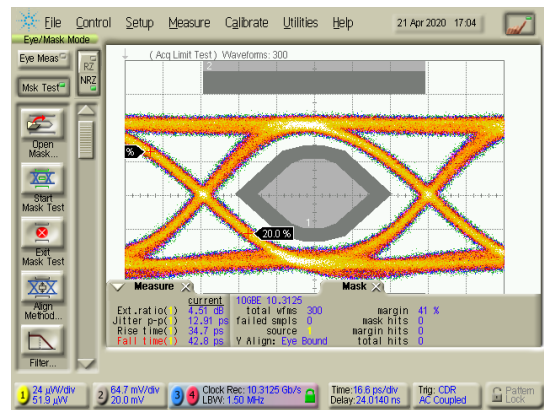
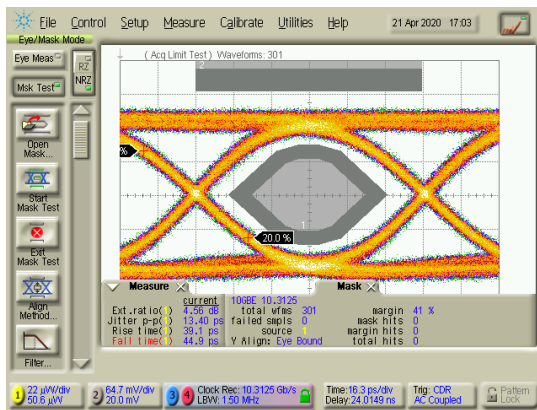
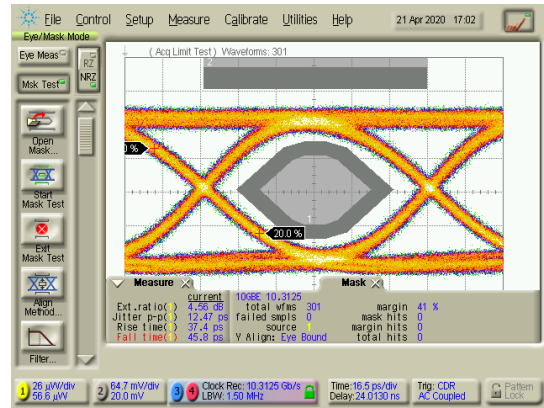
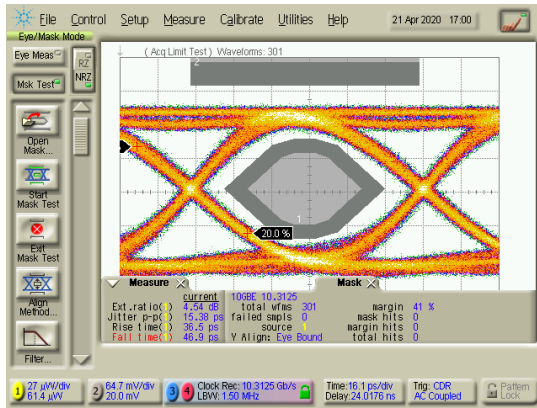

A0H Lower Page 00h Register Map

Memory Map(2-Wire Serial Address 1010000xb, Lower Page 00h)					
IIC Addr	Size	Name	Description	Type	Value (HEX)
0	1	Identifier	QSFP+	R	0D
1	1	Revision Compliance	SFF-8636 Rev2.10	R	08
2	1	status	Bit 2 = 0b: Paging (at least upper page 03h implemented) Bit 1 = 1b: IntL not asserted Bit 0 = 0b: valid data can be read	R	02
3	1	Interrupt Flags (Clear on read)	Bit 7-4: Latched Tx4 - Tx1 LOS indicator Bit 3-0: Latched Rx4 - Rx1 LOS indicator	R	00
4	1	Interrupt Flags (Clear on read)	Bit 7-4: Latched Tx4 - Tx1 input Adaptive EQ fault indicator, not implement Bit 3-0: Latched Tx4 - Tx1 Transmitter/Laser fault indicator	R	00
5	1	Interrupt Flags (Clear on read)	Bit 7-4: Latched Tx4 - Tx1 CDR LOL indicator, not implement Bit 3-0: Latched Rx4 - Rx1 CDR LOL indicator, not implement	R	00
6	1	Interrupt Flags (Clear on read)	Bit 7-4: Latched abnormal temperature indicator, include alarm and/or warning Bit 1: TC readiness flag, not implement Bit 0: Initialization complete flag, value is 0b means nitialization and/or reset has completed.	R	00
7	1	Interrupt Flags	Bit 7-4: Latched abnormal supply voltage indicator, include alarm and/or warning	R	00
8	1	Vendor Specific	Initialize to 00(hex)	R	
9-10	2	Interrupt Flags (Clear on read)	Latched abnormal Rx Power voltage indicator, include alarm and/or warning	R	0000
11-12	2	Interrupt Flags (Clear on read)	Latched abnormal Tx Bias current indicator, include alarm and/or warning	R	0000
13-14	2	Interrupt Flags (Clear on read)	Latched abnormal Tx Power voltage indicator, include alarm and/or warning	R	0000
15-18	4	Reserved	Initialize to 00(hex)	R	
19-21	3	Vendor Specific	Initialize to 00(hex)	R	

22-23	2	Temperature	Temperature diagnosis, LSB is 1/256 °C	R	
24-25	2	Reserved	Initialize to 00(hex)	R	
26-27	2	Supply Voltage	Supply Voltage diagnosis, LSB is 100 uV	R	
28-29	2	Reserved	Initialize to 00(hex)	R	
30-33	4	Vendor Specific	Initialize to 00(hex)	R	
34-35	2	Rx1 Power	Rx1 average receive power diagnosis, LSB is 0.1 uW	R	
36-37	2	Rx2 Power	Rx2 average receive power diagnosis, LSB is 0.1 uW	R	
38-39	2	Rx3 Power	Rx3 average receive power diagnosis, LSB is 0.1 uW	R	
40-41	2	Rx4 Power	Rx4 average receive power diagnosis, LSB is 0.1 uW	R	
42-43	2	Tx1 Bias	Tx1 bias current diagnosis, LSB is 2 uA	R	
44-45	2	Tx2 Bias	Tx2 bias current diagnosis, LSB is 2 uA	R	
46-47	2	Tx3 Bias	Tx3 bias current diagnosis, LSB is 2 uA	R	
48-49	2	Tx4 Bias	Tx4 bias current diagnosis, LSB is 2 uA	R	
50-51	2	Tx1 Power	Tx1 average launch power diagnosis, LSB is 0.1 uW	R	
52-53	2	Tx2 Power	Tx2 average launch power diagnosis, LSB is 0.1 uW	R	
54-55	2	Tx3 Power	Tx3 average launch power diagnosis, LSB is 0.1 uW	R	
56-57	2	Tx4 Power	Tx4 average launch power diagnosis, LSB is 0.1 uW	R	
58-73	16	Reserved	Initialize to 00(hex)	R	
74-81	8	Vendor Specific	Initialize to 00(hex)	R	
82-85	4	Reserved	Initialize to 00(hex)	R	
86	1	Tx Disable	Bit 3-0: Tx4 - Tx1 Disable, write 1b to close corresponding channel laser	R/W	00
87	1	Rx Rate select	Rx software rate select, not implement, fixed 10G mode	R/W	00
88	1	Tx Rate select	Tx software rate select, not implement, fixed 10G mode	R/W	00
89-92	4	Reserved	Initialize to 00(hex)	R/W	

93	1	Control	<p>Bit 7: Software reset is a self-clearing bit, write 1b to trigger a module reset</p> <p>Bit 1: Power set, write 1b to enable Low Power Mode, the module power consumption is lower than 1.5W</p>	R/W	00
94-97	4	Reserved	Initialize to 00(hex)	R/W	
98	1	TX/RX CDR Control	module doesn't have CDR circuit, not implement. Initialize to 00(hex)	R/W	00
99	1	Control	<p>Bit 1: LPMode/TxDis input signal control, not implement</p> <p>Bit 0: IntL/LOSL output signal control, not implement</p>	R/W	00
100	1	Mask	<p>Bit 7-4: Masking bit for Tx4 - Tx1 LOS indicator</p> <p>Bit 3-0: Masking bit for Rx4 - Rx1 LOS indicator</p>	R/W	00
101	1	Mask	<p>Bit 7-4: Masking bit for Tx4 - Tx1 Adaptive EQ fault, not implement</p> <p>Bit 3-0: Masking bit for Tx4 - Tx1 Transmitter fault</p>	R/W	00
102	1	Mask	<p>Bit 7-4: Masking bit for Tx4 - Tx1 CDR Loss of Lock, not implement</p> <p>Bit 3-0: Masking bit for Rx4 - RX1 CDR Loss of Lock, not implement</p>	R/W	00
103	1	Mask	<p>Bit 7-4: Masking bit for temperature abnormal indicator, include alarm and/or warning</p> <p>Bit 1: Masking bit for TC readiness flag, not implement</p>	R/W	00
104	1	Mask	Bit 7-4: Masking bit for Vcc abnormal indicator, include alarm and/or warning	R/W	00
105-106	2	Vendor Specific	Initialize to 0001(hex)	R/W	0001
107	1	Max Power Consumption	Maximum power consumption of module, LSB is 0.1 W	R	19
108-109	2	Propagation Delay	propagation delay, not implement	R	00
110	1	Free Side Device Properties	not implement	R	00
111-112	2	use by PCI Express	PCI Express relevant Specification, not implement	R/W	0000

113	1	Far-End and Near-End Implementation	Bit 6-4: Far-End Implementation, not implement Bit 3-0: Near-End Implementation, not implement	R	00
114	1	use by microQSFP	microQSFP MSA function, not implement	R	00
115-116	2	Reserved	not implement	R	0000
117-118	2	Reserved	not implement	R/W	0000
119-122	4	Password Change Entry	Rewrite the fixed side manufacturer passwords entry, set to 00000000(hex) on power-up. The 4 bytes are write-only, read result always be 00(hex)	W	00000000
123-126	4	Password Entry	Write password to enter fixed or free side device mode. Set to 00000000(hex) on power-up. The 4 bytes are write-only, read result always be 00(hex)	W	00000000
127	2	Page Select	Select the upper page, for example write 02(hex) indicates upper memory Page 02h is mapped	R/W	00

A0 Write Protection

The module implement write protection of upper Page 00h and 02h of 2-Wire Serial Address 1010000x (A0 Device). User must enter the fixed side mode, if you want to rewrite the upper Page 00h and 02h area register data. The way to enter the fixed side mode is enter the default fixed mode password, 00001011(hex), to registers 123-126 of A0 device.

In this Version, fixed side system manufacturer passwords can be changed by writing a new password in Bytes 119-122 when the correct current fixed side manufacture password has been entered in 123-126, with the high order bit being ignored and forced to a value of 0 in the new password.

A0H Upper Page 00h Register Map

Memory Map(2-Wire Serial Address 1010000xb, Upper Page 00h)					
IIC Addr	Size	Name	Description	Type	Value (HEX)
128	1	Identifier	QSFP+	R	0D
129	1	Ext. Identifier	Power Class 3 (2.5 W max.), No CLEI code present in Page 02h, No CDR in Tx and Rx	R	80
130	1	Connector Type	Dual-LC (Lucent Connector)	R	07
131-138	8	Specification Compliance	40GBASE-LR4, Long distance (L), Longwave laser (LC), Single Mode (SM)	R	02000000 10100100
139	1	Encoding	64B/66B	R	05
140	1	Singaling rate,nominal	Unit is 100 Megabaud	R	67
141	1	Extended Rate Select Compliance	Rate select is not implement	R	00
142	1	Length (SMF)	Unit is kilometers	R	0A
143	1	Length (OM3 50um)	Unit is 2 meters	R	4B
144	1	Length (OM2 50um)	Unit is 2 meters	R	00
145	1	Length (OM1 62.5um)	Unit is 1 meter	R	00
146	1	Length (OM4 50um)	Unit is 2 meters	R	4B
147	1	Device technology	1310nm DFB, No wavelength control, Uncooled transmitter device, Pin detector, Transmitter not tunable	R	40
148-163	16	Vendor name	UNIVISO	R	ASCII Format
164	1	Extended Module	Do not support Infiniband application	R	00
165-167	3	Vendor OUI	IEEE Company Identifier for the vendor	R	000000
168-183	16	Vendor PN	Vendor Part Number	R	ASCII Format
184-185	2	Vendor rev	Vendor Part Revision Number	R	ASCII Format
186-187	2	Wavelength	Unit is 0.05nm	R	666C
188-189	2	Wavelength tolerance	Unit is 0.005nm	R	0514
190	1	Max case temp.	Unit is °C	R	46

191	1	CC_BASE	The check code of bytes from 128 to 190	R	
192	1	Link codes	Reserved	R	00
193-195	3	Options	Tx input equalizers, Rx output emphasis, or Rx output amplitude fixed-programmable settings is implemented. Tx/Rx Squelch Disable is implemented. Tx Squelch is implemented. Memory Page 02 provided. Tx_Disable is implemented.	R	070B90
196-211	16	Vendor SN	Vendor part Serial Number	R	ASCII Format
212-219	8	Date Code	Vendor's date code of production	R	ASCII Format
220	1	Diagnostic Monitoring Type	Temperature, supply voltage, received average power and transmitter average power monitoring are implemented.	R	3C
221	1	Enhanced Options	Initialization Complete Flag and software reset are implemented	R	11
222	1	Baud Rate,nominal	Unit is 250 MBd.	R	00
223	1	CC_EXT	The check code of bytes from 192 to 222	R	
224-255	32	Vendor Specific	Vendor Specific information	R	

A0H Upper Page 02h Register Map

Memory Map(2-Wire Serial Address 1010000xb, Upper Page 02h)					
IIC Addr	Size	Name	Description	Type	Value (HEX)
128-255	128	user-writable EEPROM	The fixed side can read or write this memory for any purpose.	R	

Notes:

1.The value of A0H Upper Page 00h and 02h Register Map is general version. The actual data written may be changed due to user compatibility without prior notice.

A0H Upper Page 03h Register Map

Memory Map(2-Wire Serial Address 1010000xb, Upper Page 03h)					
IIC Addr	Size	Name	Description	Type	Value (HEX)
128-129	2	Temp High Alarm	Value is 80°C	R	5000
130-131	2	Temp Low Alarm	Value is -10°C	R	F600
132-133	2	Temp High Warning	Value is 75°C	R	4B00
134-135	2	Temp Low Warning	Value is -5°C	R	FB00
144-145	2	Vcc High Alarm	Value is 3.7V	R	9088
146-147	2	Vcc Low Alarm	Value is 2.9V	R	7170
148-149	2	Vcc High Warning	Value is 3.6V	R	8C70
150-151	2	Vcc Low Warning	Value is 3.0V	R	7548
176-177	2	Rx Power High Alarm	Value is 4.5dBm	R	6E18
178-179	2	Rx Power Low Alarm	Value is -16.4dBm	R	00E5
180-181	2	Rx Power High Warning	Value is 2.5dBm	R	4577
182-183	2	Rx Power Low Warning	Value is -14.4dBm	R	016B
184-185	2	Tx Bias High Alarm	Value is 75mA	R	927C
186-187	2	Tx Bias Low Alarm	Value is 10mA	R	1388
188-189	2	Tx Bias High Warning	Value is 70mA	R	88B8
190-191	2	Tx Bias Low Warning	Value is 15mA	R	1D4C
184-185	2	Tx Power High Alarm	Value is 4.3dBm	R	6930
186-187	2	Tx Power Low Alarm	Value is -8.2dBm	R	05E9
188-189	2	Tx Power High Warning	Value is 3.3dBm	R	5383
190-191	2	Tx Power Low Warning	Value is -7dBm	R	07CB

Notes:

1. Register Type property : 'R' means Read-only; 'R/W' means read or write operations are supported; 'W' means Write-only, the read result is fixed at 00(hex) .
2. Alarm and Warning threshold information can be defined according to customer requirements. Please connect us if you need.
3. When the digital diagnosis results of Temperature, Vcc, Bias Current, Tx Power and Rx Power, are exceed the limits defined at upper page 03h of A0 device, the related Interrupt Flags will be set to 1b to alert to users.

Block-Diagram-of-Transceiver

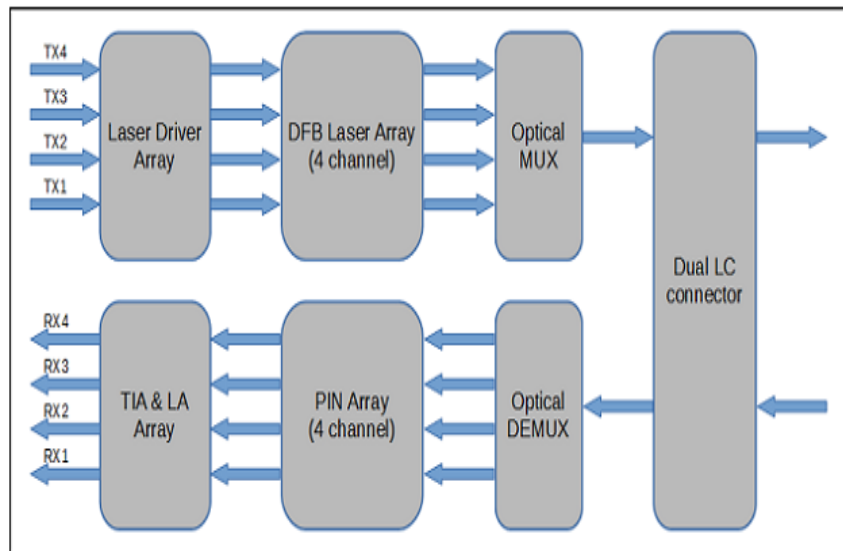

Channel Map

Channel (QSFP+ MSA Specification)	LAN (IEEE802.3 Specification)	Center Wavelength
TX1/RX1	L0	1271nm
TX2/RX2	L1	1291nm
TX3/RX3	L2	1311nm
TX4/RX4	L3	1331nm

Functions Description

The transmitter uses 2 laser driver chips to drive a 1×4 DFB array of lasers to complete the electro-optical conversion, convert 4 10Gbps-electrical-signals to 4 CWDM-optical-signals. Optical multiplexer multiplexes the 4 CWDM-optical-signals to a 40Gbps data, which output to outside of the module through Lucent Connector.

The receiver uses a demultiplexer to demultiplex the received 40Gbps optical-signal into 4 CWDM-optical-signals. 4 CWDM-optical-signals here refers to optical signals whose center wavelengths of 1271, 1291, 1311, 1333 nm. Each wavelength of optical signals is collected by a separate photodiode and converted into a weak electrical signal. The weak electrical signal is amplified and processed by the trans-impedance amplifier (TIA) and Limiting amplifier (LA), then sent to the host.

There is no CDR function inside the transceiver.

Dimensions

Modele weight: 33.4g

Dust cap weight: 0.95g

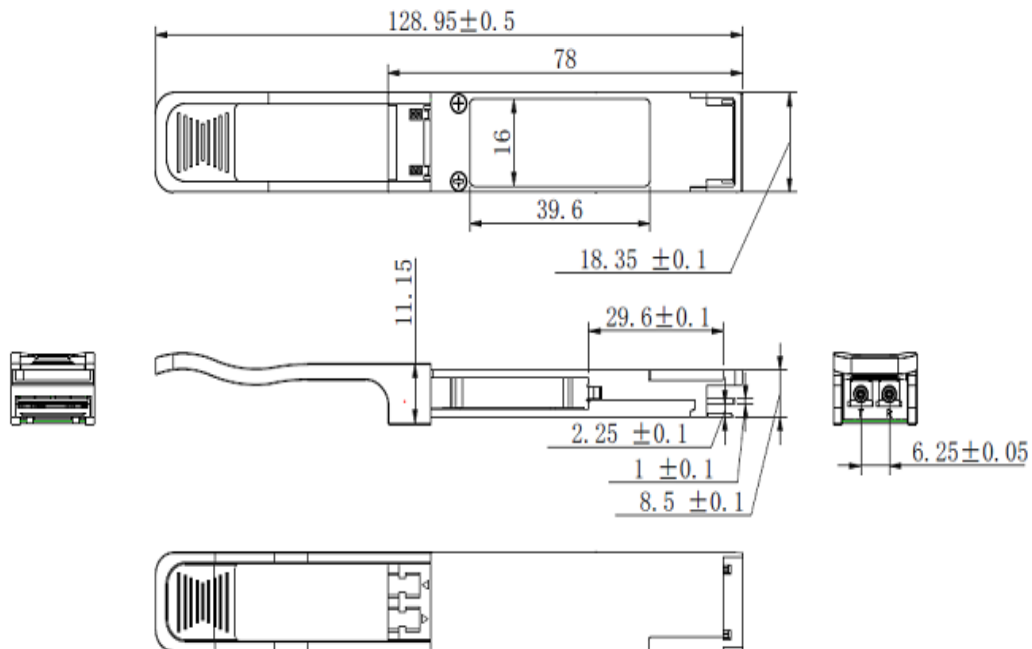

ALL DIMENSIONS ARE $\pm 0.2\text{mm}$ UNLESS OTHERWISE SPECIFIED
UNIT: mm

Electrical Pad Layout

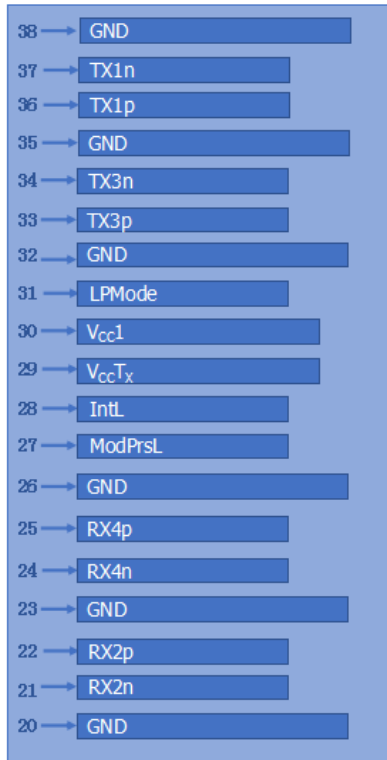

Top of Board

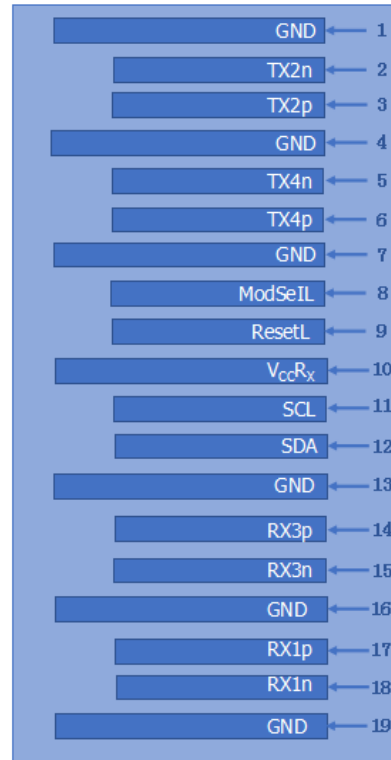

Bottom of Board

Pin Assignment

PIN #	Symbol	Description	Remarks
1	GND	Ground	5
2	Tx2n	TX2 Transmitter Inverted Data Input	
3	Tx2p	TX2 Transmitter Non-Inverted Data Input	
4	GND	Ground	5
5	Tx4n	TX4 Transmitter Inverted Data Input	
6	Tx4p	TX4 Transmitter Non-Inverted Data Input	
7	GND	Ground	5
8	ModSelL	Module select pin, the module responds to two-wire serial communication when low level	1
9	ResetL	Module Reset	2
10	V _{cc} R _X	+3.3V Power Supply Receiver	
11	SCL	2-wire serial interface clock	
12	SDA	2-wire serial interface data	
13	GND	Ground	5
14	Rx3p	Rx3 Receiver Non-Inverted Data Output	
15	Rx3n	Rx3 Receiver Inverted Data Output	
16	GND	Ground	5
17	Rx1p	Rx1 Receiver Non-Inverted Data Output	
18	Rx1n	Rx1 Receiver Inverted Data Output	
19	GND	Ground	5
20	GND	Ground	5
21	Rx2n	Rx2 Receiver Inverted Data Output	
22	Rx2p	Rx2 Receiver Non-Inverted Data Output	
23	GND	Ground	5
24	Rx4n	Rx4 Receiver Inverted Data Output	
25	Rx4p	Rx4 Receiver Non-Inverted Data Output	
26	GND	Ground	5
27	ModPrsL	The pin grounded in the module indicates the status of the module inserted into the host. When voltage level is high, the module status is inserted.	
28	IntL	Interrupt	3
29	V _{cc} T _X	+3.3V Power Supply transmitter	
30	V _{cc} 1	+3.3V Power Supply	
31	LPMMode	Low Power Mode	4

32	GND	Ground	5
33	Tx3p	Tx3 Transmitter Non-Inverted Data Input	
34	Tx3n	Tx3 Transmitter Inverted Data Input	
35	GND	Ground	5
36	Tx1p	Tx1 Transmitter Non-Inverted Data Input	
37	Tx1n	Tx1 Transmitter Inverted Data Input	
38	GND	Ground	5

Notes:

1. ModSelL is the input pin. The module responds to 2-wire serial communication commands when it is held low by the host. ModSelL allows multiple QSFP modules to be used on a single 2-wire interface bus. If ModSelL is High, the module will not respond to any 2-wire interface communication from the host. ModSelL has internal pull-up resistors in the module
2. The module reset pin. A low level on the ResetL pin for longer than the minimum pulse length (t_{Reset_init}), 2 us, initiates a complete module reset, returning all user module settings to their default state. See MSA standards for related timing specifications.
3. This pin is the open-collector output pin. It shall be pulled up towards Vcc on the host board use 4.7-10 K Ω resistor. When “Low”, it indicates a possible module operational fault or a status critical to the host system. The host identifies the source of the interrupt using the 2-wire serial interface.
4. When this pin is asserted high level, it indicates the module operate in low power mode and the module power consumption is lower than 1.5 Watts.
5. Circuit ground is internally isolated from chassis ground.

References

1. IEEE standard 802.3ba. IEEE Standard Department, 2010.
2. QSFP+ 10Gbps 4X PLUGGABLE TRANSCEIVER –SFF-8436 V4.9, 2018.
3. Management Interface for 4-lane Modules and Cables –SFF-8636 Rev 2.10a, 2019.