

DATA SHEET

UDQ1HE3B

100GBase-ER QSFP28 PSM4, BIDI 1270&1330nm,30km, LC Transceiver

Features

- Supports 100GBASE-ER BIDI
- Lane signaling rate 106.25Gb/s with PAM4
- Up to 30km transmission on SMF
- EML laser and APD receiver
- 4x25.78Gb/s with NRZ electrical interface (CAUI-4)
- High speed I/O electrical interface
- I2C interface with integrated Digital Diagnostic monitoring
- QSFP28 MSA package with simplex LC connector
- Single +3.3V power supply
- Maximum power consumption 4.5 W
- Operating case temperature: 0 to +70 °C
- Compliant to 802.3cu, SFF-8636&SFF-8679 standard
- Complies with EU Directive 2015/863/EU

Application

- 100GBASE-ER1-30 BIDI;

Order Information

Table 1- order information

Part No.	Data Rate	Laser	Fiber Type	Distance	Optical Interface	Temp	DDMI	Latch Color
UDQ1HE3B-G	106.25Gbps	Tx13xx/Rx13xx	SMF	30km	LC	0~70C	Y	Green
UDQ1HE3B-B	106.25Gbps	Tx13xx/Rx13xx	SMF	30km	LC	0~70C	Y	Blue

Absolute Maximum Ratings

Table 2-Absolute Maximum Ratings

Parameter	Symbol	Min.	Typical	Max.	Unit	Notes
Storage Temperature	T _s	-40	-	+85	°C	
Supply Voltage	V _{cc}	-0.5	-	+4.0	V	
Operating Relative Humidity	RH	-	-	+85	%	

Recommended Operating Conditions

Table 3-Recommended Operating Conditions

Parameter	Symbol	Min.	Typical	Max.	Unit	Notes
Operating Case Temperature	T _c	0	-	+70	°C	
Power Supply Voltage	V _{cc}	3.13	3.3	3.47	V	

Power Supply Current	I _{cc}	-	-	1.3	A	
Maximum Power Dissipation	P _D	-	-	4.5	W	
Data Rate(optical)	DR _o	-	106.25	-	Gb/s	
Transmission Distance	TD	-	-	30	km	Over SMF

Optical Characteristics

Table 4-Optical Characteristics

Transmitter						
Parameter	Symbol	Min.	Typical	Max.	Unit	Notes
Center Wavelength	CW	1303.54	1304.58	1305.63	nm	
		1308.09	1309.14	1310.19	nm	
Average Launch Power	P _{TX}	0	-	5.6	dBm	1
Outer Optical Modulation Amplitude	OMA	3.0	-	6.4	dBm	TDECQ < 1.4
		1.6+TDECQ	-			TDECQ > 1.4
Transmitter and dispersion eye closure for PAM4 (TDECQ) (max)	TDECQ	-	-	3.9	dBm	
TDECQ-TECQ		-	-	2.7	dB	
Average Output Power (Laser Turn off)	P _{OUT-OFF}	-	-	-15	dBm	
Side Mode Suppression Ratio	SMSR	30	-	-	dB	
Extinction Ratio	ER	5	-	-	dB	
Receiver						
Center Wavelength	CW	1308.09	1309.14	1310.19	nm	
		1303.54	1304.58	1305.63	nm	
Damage threshold	P _{damage}	-2.4	-	-	dBm	2
Average Rx Power	P _{RX}	-14.7	-	-3.4	dBm	3
Receive power_OMAouter	P _{OMA}	-	-	-2.6	dBm	
Receiver sensitivity_OMAouter	SEN _{OMA}	-	-	-12.5	dBm	4
Los Assert	LosA	-26	-	-	dBm	
Los De-Assert	LosDA	-	-	-15	dBm	
Los Hysteresis	LosH	0.5	-	-	dB	

Notes:

1. The optical power is launched into SMF.
2. The receiver shall be able to tolerate, without damage, continuous exposure to an optical input signal having this average power level. The receiver does not have to operate correctly at this input power.
3. Average receive power, each lane (min) is informative and not the principal indicator of signal strength.
4. Measured with conformance test signal at TP3 using the test pattern PRBS31Q or scrambled idle for stressed receiver sensitivity for the BER= 2.4x10⁻⁴.

Electrical Characteristics

High-Speed Signal: Compliant to CAUI-4 (IEEE 802.3cu)

Low-Speed Signal: Compliant to SFF-8679.

Table 5-Electrical Characteristics

Transmitter (Module Input)						
Parameter	Symbol	Min.	Typical	Max.	Unit	Notes
Input Differential Impedance	R _{in}	-	100	-	Ohm	
Differential Data Input Amplitude	V _{IN,P-P}	80	-	900	mVpp	
Differential termination mismatch (max)	D-mismatch	-	-	10	%	

DC common-mode input voltage		-0.3	-	2.8	V	
Transition time(20%~80%)	Tr Tf	10	-	-	ps	
LPMode, Reset and ModSeIL / Tx dis	V _{IL}	-0.3	-	0.8	V	
LPMode, Reset and ModSeIL / Tx dis	V _{IH}	2.0	-	V _{CC} +0.3	V	
Receiver (Module Output)						
Output Differential Impedance	R _{out}	-	100	-	Ohm	
Differential Data Output Amplitude	V _{OUT,P-P}	-	-	900	mVpp	
Differential termination mismatch (max)	D-mismatch	-	-	10	%	
Transition time, 20% to 80%	Tr Tf	12	-		ps	
ModPrsL and IntL/ Rx los	V _{OL}	0	-	0.4	V	
ModPrsL and IntL/ Rx los	V _{OH}	V _{CC} -0.5	-	V _{CC} +0.3	V	

Digital Diagnostics

Table 6-Digital Diagnostics

Parameter	Range	Accuracy	Unit	Calibration
Temperature	0 to 70	±3	°C	Internal
Voltage	0 to V _{CC}	0.1	V	Internal
Tx Bias Current	0 to 100	10%	mA	Internal
Tx Output Power	0 to 5.6	±3	dBm	Internal
Rx Power	-14.7 to -3.4	±3	dBm	Internal

Pin Definitions

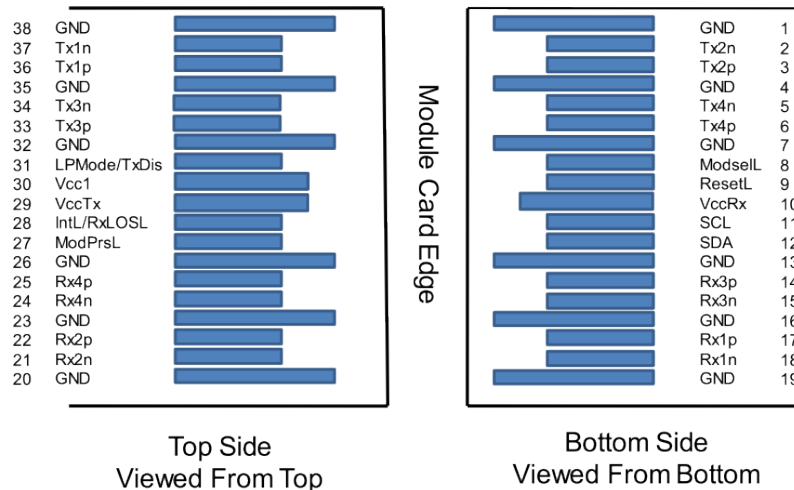

PIN	Logic	Symbol	Description	Plug Seq.	Notes
1		GND	Ground	1	1
2	CML-I	Tx2n	Transmitter Inverted Data Input	3	
3	CML-I	Tx2p	Transmitter Non-Inverted Data output	3	
4		GND	Ground	1	1
5		NC		3	
6		NC		3	

7		GND	Ground	1	1
---	--	-----	--------	---	---

8	LVTLL-I	ModSelL	Module Select	3	
9	LVTLL-I	ResetL	Module Reset	3	
10		VccRx	+ 3.3V Power Supply Receiver	2	2
11	LVC MOS-I/O	SCL	2-Wire Serial Interface Clock	3	
12	LVC MOS-I/O	SDA	2-Wire Serial Interface Data	3	
13		GND	Ground	1	
14		NC		3	
15		NC		3	
16		GND	Ground	1	1
17	CML-O	Rx1p	Receiver Non-Inverted Data Output	3	
18	CML-O	Rx1n	Receiver Inverted Data Output	3	
19		GND	Ground	1	1
20		GND	Ground	1	1
21	CML-O	Rx2n	Receiver Inverted Data Output	3	
22	CML-O	Rx2p	Receiver Non-Inverted Data Output	3	
23		GND	Ground	1	1
24		NC		3	
25		NC		3	
26		GND	Ground	1	1
27	LVTTL-O	ModPrsL	Module Present	3	
28	LVTTL-O	IntL	Interrupt	3	
29		VccTx	+3.3 V Power Supply transmitter	2	2
30		Vcc1	+3.3 V Power Supply	2	2
31	LVTTL-I	LPMODE	Low Power Mode	3	
32		GND	Ground	1	1
33		NC		3	
34		NC		3	
35		GND	Ground	1	1
36	CML-I	Tx1p	Transmitter Non-Inverted Data Input	3	
37	CML-I	Tx1n	Transmitter Inverted Data Output	3	
38		GND	Ground	1	1

Note 1: GND is the symbol for signal and supply (power) common for the QSFP28 module. All are common within the QSFP28 module and all module voltages are referenced to this potential unless otherwise noted. Connect these directly to the host board signal-common ground plane.

Note 2: Vcc Rx, Vcc1 and Vcc Tx are the receiver and transmitter power supplies and shall be applied concurrently. Requirements defined for the host side of the Host Edge Card Connector are listed in MSA. The connector pins are each rated for a maximum current of 1000 mA.

Mechanical Dimension

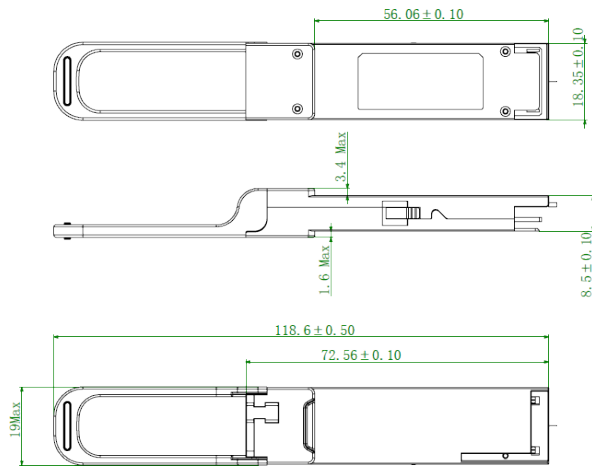

Warnings

Handling Precautions: This device is susceptible to damage as a result of electrostatic discharge (ESD). A static free environment is highly recommended. Follow guidelines according to proper ESD procedures.

Laser Safety: Radiation emitted by laser devices can be dangerous to human eyes. Avoid eye exposure to direct or indirect radiation.