

DATA SHEET

Product Specification

10Gbps SFP+ SR Transceiver, 300m MMF Reach 850nm

Features

- Electrical interface compliant to SFF-8431
- Lane bit rate 10.3 Gb/s
- 850nm VCSEL laser and PIN photo-detector
- I2C interface with integrated Digital Diagnostic monitoring
- Single +3.3V power supply
- Hot Pluggable
- Maximum link length of 300m on OM3 MMF
- Operating case temperature
Commercial: 0°C to +70 °C
Industrial: -40°C to +85 °C
- RoHS compliant

Application

- 10 Gigabit Ethernet
- 1 x InfiniBand QDR, DDR, SDR
- High-performance computing clusters
- 4G and 8G Fiber Channel Applications
- Servers, switches, storage and host card adapters;

Order Information

Table 1- order information

Part No.	Data Rate	Laser	Fiber Type	Distance	Optical Interface	Temp	DDMI
UYS10SRD	10Gbps	850nm	MMF	300m	LC	0°C ~70°C	Y
UYS10SRDI	10Gbps	850nm	MMF	300m	LC	-40°C ~85°C	Y

Absolute Maximum Ratings

Table 2-Absolute Maximum Ratings

Parameter	Symbol	Min.	Typical	Max.	Unit	Notes
Storage Temperature	T _s	-40	-	+85	°C	
Supply Voltage	V _{cc}	-0.3	-	+3.6	V	
Operating Relative Humidity	RH	0	-	+85	%	no condensation

Recommended Operating Conditions

Table 3-Recommended Operating Conditions

Parameter	Symbol	Min.	Typical	Max.	Unit	Notes
Operating Case Temperature	T _c	0	-	+70	°C	TLP850M10G

		-40	-	+85	°C	TLP850M10GI
Power Supply Voltage	V _{CC}	3.13	3.3	3.47	V	
Power Supply Current	I _{CC}	-	-	250	MA	
Maximum Power Dissipation	P _D	-	-	0.87	W	
Data Rate	DR _{AVE}	-	10.312	-	Gb/s	
Transmission Distance	TD		-	300	m	Over MMF

Optical Characteristics

Table 4-Optical Characteristics

Transmitter						
Parameter	Symbol	Min.	Typical	Max.	Unit	Notes
Center Wavelength	λ	840	850	860	nm	
RMS spectral width				0.65	nm	
Average Optical Power	P _{avg}	-6.5	-	-1	dBm	1
Extinction Ratio	ER	3	-	-	dB	2
Transmitter and Dispersion Penalty	TDP	-	-	3.9	dB	
Optical Return Loss Tolerance	ORLT	-	-	20	dB	
Relative Intensity Noise	R _{in}			-128	dB/Hz	
Receiver						
Center Wavelength	λ_r	840	850	860	nm	
Receiver Sensitivity	P _{sens}			-9.9	dBm	3
Stressed Sensitivity in OMA				-7.5	dBm	3
Receiver Overload	P _{IN-OL}		-	2.4	dBm	3
Reflectance	Ref	-	-	-12	dB	
LOS Assert	LOS _A	-30	-	-	dBm	
LOS De-assert	LOS _D	-	-	-12	dBm	
LOS Hysteresis	LOS _H	0.5	-	6	dB	

Notes:

1. The optical power is launched into MMF
2. Measured with a PRBS 2³¹-1 test pattern @10.3125Gbps
3. Measured with a PRBS 2³¹-1 test pattern @10.3125Gbps, BER≤10⁻¹².

Electrical Characteristics

Table 5-Electrical Characteristics

Transmitter (Module Input)						
Parameter	Symbol	Min.	Typical	Max.	Unit	Notes
Differential Data Input Amplitude	V _{IN,P-P}	200	-	1600	mVpp	
Differential Termination Mismatch		-	-	10	%	
Tx_Disable	Normal Operation	V _{IL}	-0.3	-	0.8	V
	Laser Disable	V _{IH}	2.0	-	V _{CC} +0.3	V
Receiver (Module Output)						
Differential Data Output Amplitude	V _{OUT,P-P}	370	-	1600	mVpp	
Differential Termination Mismatch (1MHZ)		-	-	10	%	
Output Rise/Fall Time, 20%~80%	T _R	12	-	-	ps	
Rx_LOS	Normal Operation	V _{OL}	-	-	0.4	V

	Lose Signal	V _{OH}	V _{CC} -0.5	-	-	V	
--	-------------	-----------------	----------------------	---	---	---	--

Digital Diagnostics

Table 6-Digital Diagnostics

Parameter	Range	Accuracy	Unit	Calibration
Temperature	0 to 70 or -40 to 85	±3	°C	Internal
Voltage	0 to V _{CC}	0.1	V	Internal
Tx Bias Current	0 to 10	10%	mA	Internal
Tx Output Power	-1 to -6.5	±3	dBm	Internal
Rx Power	-1 to -9.9	±3	dBm	Internal

Pin Definitions

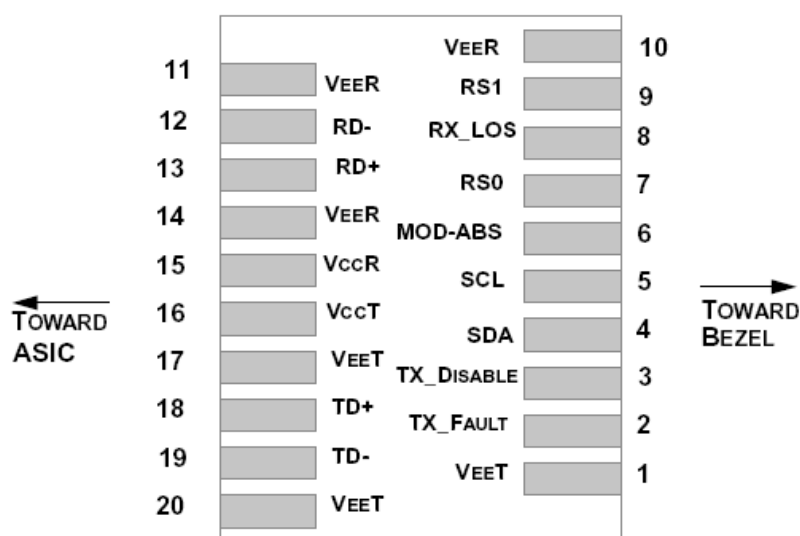

Pin	Name	FUNCTION	Plug Seq.	Notes
1	VeeT	Transmitter Ground	1	Note 5
2	TX Fault	Transmitter Fault Indication	3	Note 1
3	TX Disable	Transmitter Disable	3	Note 2, Module disables on high or open
4	SDA	Module Definition 2	3	2-wire Serial Interface Data Line.
5	SCL	Module Definition 1	3	2-wire Serial Interface Clock.
6	MOD_ABS	Module Definition 0	3	Note 3
7	RS0	RX Rate Select (LVTTTL).	3	Rate Select 0, optionally controls SFP+ module receiver. This pin is pulled low to VeeT with a >30K resistor..
8	LOS	Loss of Signal	3	Note 4
9	RS1	TX Rate Select (LVTTTL).	1	Rate Select 1, optionally controls SFP+ module transmitter. This pin is pulled low to VeeT with a >30K resistor.
10	VeeR	Receiver Ground	1	Note 5
11	VeeR	Receiver Ground	1	Note 5
12	RD-	Inv. Received Data Out	3	Note 6
13	RD+	Received Data Out	3	Note 6

14	VeeR	Receiver Ground	1	Note 5
15	VccR	Receiver Power	2	3.3 ± 5%, Note 7
16	VccT	Transmitter Power	2	3.3 ± 5%, Note 7
17	VeeT	Transmitter Ground	1	Note 5
18	TD+	Transmit Data In	3	Note 8
19	TD-	Inv. Transmit Data In	3	Note 8
20	VeeT	Transmitter Ground	1	Note 5

Note:

1. TX Fault is an open collector/drain output, which should be pulled up with a 4.7K – 10KΩ resistor on the host board. Pull up voltage between 2.0V and VccT/R+0.3V. When high, output indicates a laser fault of some kind. Low indicates normal operation. In the low state, the output will be pulled to < 0.8V.
2. TX disable is an input that is used to shut down the transmitter optical output. It is pulled up within the module with a 4.7K – 10 KΩ resistor. Its states are: Low (0 – 0.8V): Transmitter on (>0.8, < 2.0V): Undefined High (2.0 – 3.465V): Transmitter Disabled Open: Transmitter Disabled
3. Module Absent, connected to VeeT or VeeR in the module.
4. LOS (Loss of Signal) is an open collector/drain output, which should be pulled up with a 4.7K – 10KΩ resistor. Pull up voltage between 2.0V and VccT/ R+0.3V. When high, this output indicates the received optical power is below the worst-case receiver sensitivity (as defined by the standard in use). Low indicates normal operation. In the low state, the output will be pulled to < 0.8V.
5. The module signal ground contacts, VeeR and VeeT, should be isolated from the module case.
6. RD-/+ : These are the differential receiver outputs. They are AC coupled 100Ω differential lines which should be terminated with 100Ω (differential) at the user SERDES. The AC coupling is done inside the module and is thus not required on the host board. The voltage swing on these lines will be between 350 and 700 mV differential (175 –350 mV single ended) when properly terminated.
7. VccR and VccT are the receiver and transmitter power supplies. They are defined as 3.3V ±5% at the SFP+ connector pin. Maximum supply current is 725mA. Recommended host board power supply filtering is shown below. Inductors with DC resistance of less than 1 ohm should be used in order to maintain the required voltage at the SFP+ input pin with 3.3V supply voltage. When the recommended supply-filtering network is used, hot plugging of the SFP+ transceiver module will result in an inrush current of no more than 30mA greater than the steady state value. VccR and VccT may be internally connected within the SFP+ transceiver module.
8. TD-/+ : These are the differential transmitter inputs. They are AC-coupled, differential lines with 100Ω differential termination inside the module. The AC coupling is done inside the module and is thus not required on the host board. The inputs will accept differential swings of 150 – 1200 mV (75 – 600mV single-ended).

Recommended Host Board Power Supply Circuit

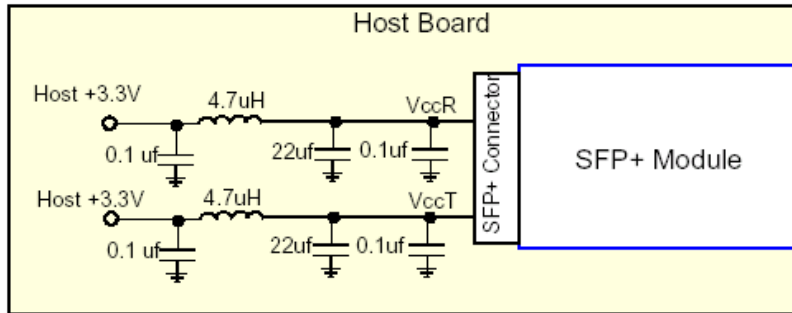

Recommended interface Circuit

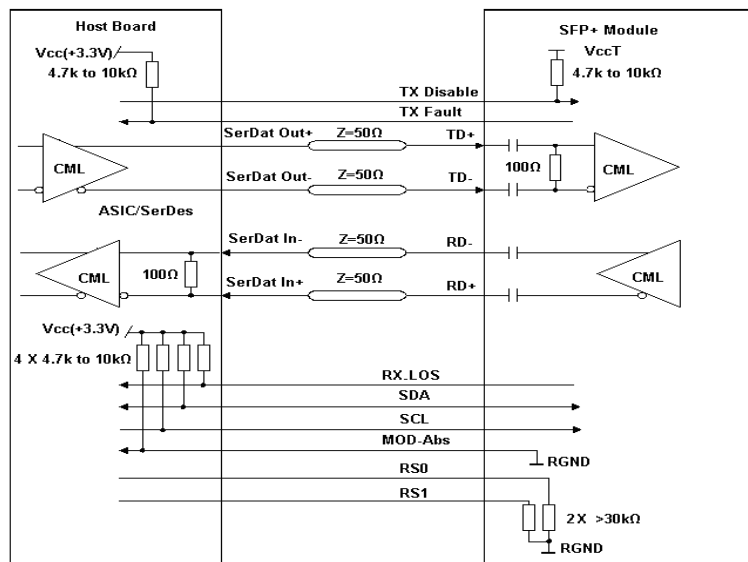

Mechanical Dimension

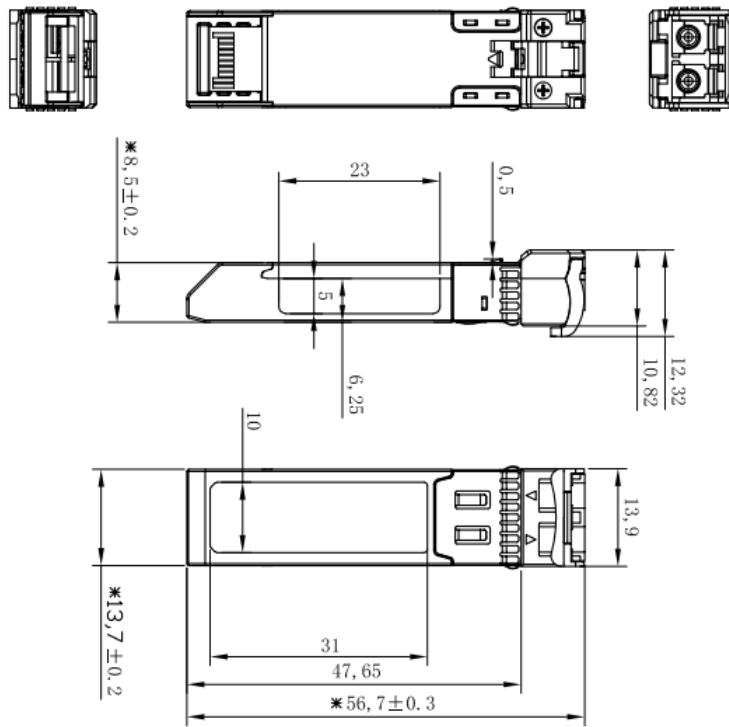

Company: mm

Warnings

Handling Precautions: This device is susceptible to damage as a result of electrostatic discharge (ESD). A static free environment is highly recommended. Follow guidelines according to proper ESD procedures.

Laser Safety: Radiation emitted by laser devices can be dangerous to human eyes. Avoid eye exposure to direct or indirect radiation.