

**DATA SHEET****UNIVISO – UMQ1HL1L  
100G QSFP28 LR4 Optical Transceiver****QSFP28-LR4 Overview**

UNIVISO's QSFP28-LR4 optical transceivers are based on 100G Ethernet IEEE 802.3ba standard. The QSFP28 transceiver converts 4 inputs channels of 25Gb/s electrical data to 4 LAN-WDM optical signals, and multiplexes them into a single channel for 100Gb/s optical transmission. Reversely, on the receiver side, the module optically de-multiplexes a 100Gb/s input into 4 LAN-WDM channels signals, and converts them to 4 channel output electrical data.

**Product Features**

- 4x25G LAN-WDM optical architecture up to 103.1Gbps
- QSFP28 MSA compliant
- Up to 10km transmission
- Duplex LC connector
- Power dissipation < 3.5W
- Built-in digital diagnostic functions
- RoHS compliant
- Operating temperature range: 0°C to 70°C.

**Applications**

- 100GBASE-LR4 100G Ethernet

**Ordering Information**

Part Number	Description
UMQ1HL1L	100G QSFP28 LC Connectors, Up to 10km on SMF, with DOM function.

**For More Information:**

UNIVISO TECHNOLOGIES&amp; DEVELOP LIMITED

Room 608, Yuanzheng Building B, Nanshan District, Shenzhen, China, 518052

Email: bruce.ke@szuniviso.com

**General Specifications**

Parameter	Symbol	Min	Typ	Max	Unit	Remarks
Bit Error Rate	BER			10 <sup>-12</sup>		
Operating Temperature	T <sub>OP</sub>	0		70	°C	1
Storage Temperature	T <sub>STO</sub>	- 40		85	°C	2
Input Voltage	V <sub>CC</sub>	3.14	3.3	3.46	V	
Maximum Voltage	V <sub>MAX</sub>	- 0.5		3.6	V	3
Module total power	P			3.5	W	

**Notes:**

1. Case temperature
2. Ambient temperature
3. For electrical power interface

**Optical Characteristics – Transmitter**

Parameter	Symbol	Min	Typ	Max	Unit	Remarks
Signaling Speed per lane			25.78125±100ppm		Gb/s	
Total Output Optical Power	P <sub>T</sub>			8.3	dBm	1
Average Launch Power (Each Lane)	P	- 4.3		4.5	dBm	
Optical Center Wavelength	λ <sub>c</sub>	1294.53	1295.56	1296.59	nm	2
		1299.02	1300.06	1301.09	nm	3
		1303.54	1304.59	1305.63	nm	4
		1308.09	1309.14	1310.19	nm	5
Optical Modulation Amplitude, Each Lane	OMA	- 1.3		4.5	dB	
Extinction Ratio	ER	4			dB	
Side Mode Suppression Ratio	SMSR	30			dB	
Relative Intensity Noise	RIN			- 130	dB/Hz	
Transmitter Dispersion Penalty	TDP			1.8	dB	
Optical Return Loss Tolerance				20	dB	
Transmitter Eye Mask				Compliant with IEEE 802.3ba		

**Notes:**

1. Average
2. L0 Lane
3. L1 Lane
4. L2 Lane
5. L3 Lane

**Optical Characteristics – Receiver**

Parameter	Symbol	Min	Typ	Max	Unit	Remarks
Signaling Speed per lane		25.78125±100ppm			Gb/s	
Optical Center Wavelength	$\lambda_c$	1294.53	1295.56	1296.59	nm	1
		1299.02	1300.06	1301.09	nm	2
		1303.54	1304.59	1305.63	nm	3
		1308.09	1309.14	1310.19	nm	4
Optical Input Power, each lane	$P_{IN}$	- 10.6		4.5	dBm	5
Receiver Sensitivity (OMA), each Lane	$R_{X\_SEN1}$			- 8.6	dBm	
LOS Assert	$LOS_A$	- 24		- 13.6	dBm	
LOS De-Assert	$LOS_D$			- 11.6	dBm	
LOS Hysteresis	$LOS_H$		1.5		dB	

**Notes:**

1. L0 Lane
2. L1 Lane
3. L2 Lane
4. L3 Lane
5. Average, Informative

**Electrical Characteristics – Transmitter**

Parameter	Symbol	Min	Typ	Max	Unit	Remarks
Signaling Rate per lane		25.78125±100ppm			Gb/s	
Differential data input swing	$V_{IN\_PP}$			900	mV	
Transmit disable voltage	$V_D$	$V_{CC}-1.3$		$V_{CC}$	V	
Transmit enable voltage	$V_{EN}$	$V_{EE}$		$V_{EE}+0.8$	V	

**Electrical Characteristics – Receiver**

Parameter	Symbol	Min	Typ	Max	Unit	Remarks
Signaling Rate per lane		25.78125±100ppm			Gb/s	
Differential data output swing	$V_{OUT\_PP}$	400		800	mV	
Data output rise time (20%-80%)	$T_R$		12		ps	
Data output fall time (20%-80%)	$T_F$		12		ps	
LOS Fault	$V_{LOS\_Fault}$	$V_{CC}-1.3$		$V_{CC\_HOST}$	V	
LOS Normal	$V_{LOS\_Normal}$	$V_{EE}$		$V_{EE}+0.5$	V	

**Block Diagram of Transceiver**

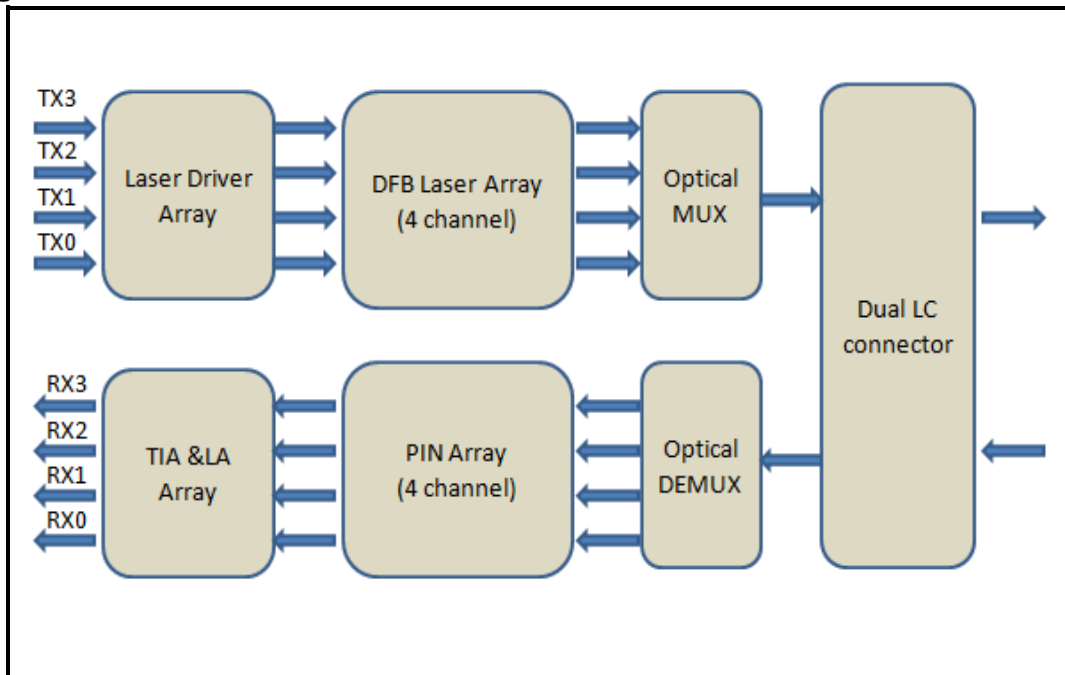

This product converts the 4-channel 25Gb/s electrical input data into LAN WDM optical signals (light), by a driven 4-wavelength Distributed Feedback Laser (DFB) array. The light is combined by the MUX parts as a 100Gb/s data, propagating out of the transmitter module from the SMF. The receiver module accepts the 100Gb/s LAN WDM optical signals input, and de-multiplexes it into 4 individual 25Gb/s channels with different wavelength. Each wavelength light is collected by a discrete photo diode, and then outputted as electric data after amplified by a TIA.

**Dimensions**

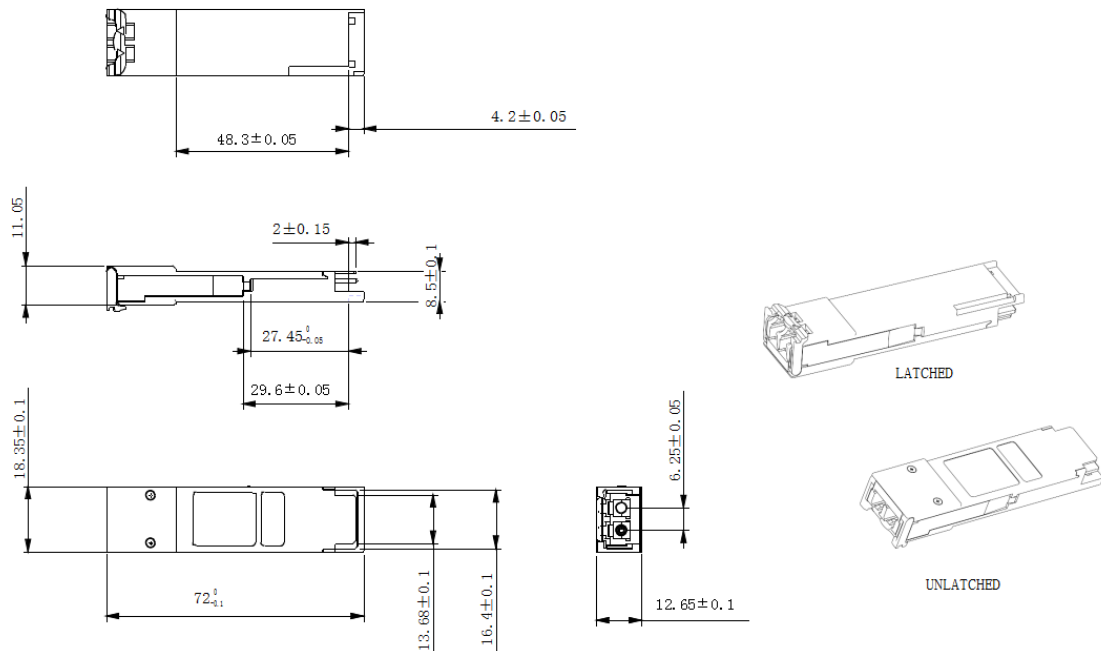

**ALL DIMENSIONS ARE  $\pm 0.2$ mm UNLESS OTHERWISE SPECIFIED**  
**UNIT: mm**

**Electrical Pad Layout**

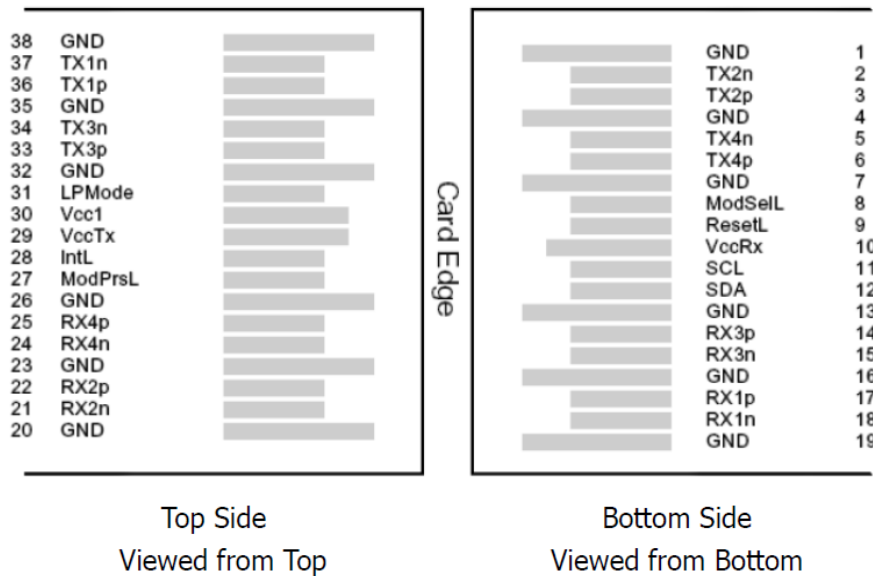

**Pin Assignment**

PIN #	Symbol	Description	Remarks
1	GND	Ground	
2	Tx2n	Transmitter Inverted Data Input	

3	Tx2p	Transmitter Non-Inverted Data Input
4	GND	Ground
5	Tx4n	Transmitter Inverted Data Input
6	Tx4p	Transmitter Non-Inverted Data Input
7	GND	Ground
8	ModSelL	Module Select
9	ResetL	Module Reset
10	V <sub>cc</sub> Rx	+3.3V Power Supply Receiver
11	SCL	2-wire serial interface clock
12	SDA	2-wire serial interface data
13	GND	Ground
14	Rx3p	Receiver Non-Inverted Data Output
15	Rx3n	Receiver Inverted Data Output
16	GND	Ground
17	Rx1p	Receiver Non-Inverted Data Output
18	Rx1n	Receiver Inverted Data Output
19	GND	Ground
20	GND	Ground
21	Rx2n	Receiver Inverted Data Output
22	Rx2p	Receiver Non-Inverted Data Output
23	GND	Ground
24	Rx4n	Receiver Inverted Data Output
25	Rx4p	Receiver Non-Inverted Data Output
26	GND	Ground
27	ModPrsL	Module Present
28	IntL	Interrupt
29	V <sub>cc</sub> Tx	+3.3V Power Supply transmitter
30	V <sub>cc1</sub>	+3.3V Power Supply
31	LPMode	Low Power Mode
32	GND	Ground
33	Tx3p	Transmitter Non-Inverted Data Input
34	Tx3n	Transmitter Inverted Data Input
35	GND	Ground
36	Tx1p	Transmitter Non-Inverted Data Input
37	Tx1n	Transmitter Inverted Data Input

38

GND

Ground

---

**References**

1. IEEE standard 802.3ba. IEEE Standard Department.
2. QSFP28 4X PLUGGABLE TRANSCEIVER – SFF-8665