

**DATA SHEET****UNIVISO – UMS10L2B23****10Gb/s SFP+ Tx1270nm/Rx1330nm Bi-directional Transceiver****SFP10-BIDI-T1270/R1330-20KM Overview**

UNIVISO's SFP10-BIDI-T1270/R1330-20KM SFP+ optical transceivers are based on 10G Ethernet IEEE 802.3ae standard and SFF-8431 standard, and provide a quick and reliable interface for the 10G Ethernet application. The digital diagnostics functions are available via the 2-wire serial bus, as specified in SFF-8472.

**Product Features**

- Supports from 9.83Gb/s to 11.3Gb/s bit rates
- Compliant with IEEE 802.3ae 10GBASE-LR/LW
- Compliant with 10GFC
- Compliant with SFF-8431
- Hot-pluggable SFP+ footprint
- 1270nm DFB laser transmitter and 1330 PIN Receiver
- Simplex LC connector
- Built-in digital diagnostic functions
- Up to 20km on SMF
- Single power supply 3.3V
- RoHS Compliant
- Operating temperature range: 0°C to 70°C.

**Applications**

- 10GBASE-LR/LW Ethernet
- 10GFC
- 10G CPRI

**Ordering Information**

Part Number	Description
UMS10L2B23	10G SFP+ BIDI, TX1270nm/RX1330nm, LC Connectors 20km on SMF, with DOM function.

**For More Information:**

UNIVISO TECHNOLOGIES& DEVELOP LIMITED

Room 608, Yuanzheng Building B, Nanshan District, Shenzhen, China, 518052

Email: bruce.ke@szuniviso.com

**General Specifications**

Parameter	Symbol	Min	Typ	Max	Unit	Remarks
Data Rate	DR	9.83		11.3	Gb/s	1
Bit Error Rate	BER			10 <sup>-12</sup>		
Operating Temperature	T <sub>OP</sub>	0		70	°C	2
Storage Temperature	T <sub>STO</sub>	- 40		85	°C	3
Supply Current	I <sub>S</sub>		230	260	mA	4
Input Voltage	V <sub>CC</sub>	3.14	3.3	3.46	V	
Maximum Voltage	V <sub>MAX</sub>	- 0.5		4	V	4

**Notes:**

1. IEEE 802.3ae
2. Case temperature
3. Ambient temperature
4. For electrical power interface

**Optical Characteristics – Transmitter**
**V<sub>CC</sub>=3.14V to 3.46V, T<sub>C</sub>=0°C to 70°C**

Parameter	Symbol	Min	Typ	Max	Unit	Remarks
Output Optical Power	P <sub>TX</sub>	- 8.2		0.5	dBm	1
Optical Center Wavelength	λ <sub>C</sub>	1260	1270	1280	nm	
Extinction Ratio	ER	3.5			dB	
Spectral Width (- 20 dB)	Δλ			0.6	nm	
Side Mode Suppression Ratio	SMSR	30			dB	
Relative Intensity Noise	RIN			- 128	dB/Hz	
Transmitter Dispersion Penalty	TDP			3.2	dB	
Transmitter Jitter		According to IEEE 802.3ae requirement				
Launch Power of OFF Transmitter	P <sub>OUT_OFF</sub>			- 30	dBm	1

**Notes:**

1. Average

**Optical Characteristics – Receiver**
**V<sub>CC</sub>=3.14V to 3.46V, T<sub>C</sub>=0°C to 70°C**

Parameter	Symbol	Min	Typ	Max	Unit	Remarks
Optical Input Power	P <sub>IN</sub>	- 14.4		0.5	dBm	1
Optical Center Wavelength	λ <sub>C</sub>	1320	1330	1340	nm	



## UMS10L2B23

Receiver Sensitivity (OMA)@ 10.3Gb/s	R <sub>X_SEN1</sub>		- 12.6	dBm	2
Stressed Receiver Sensitivity in OMA @ 10.3Gb/s	P <sub>SENS2</sub>		- 10.3	dBm	3
Receiver Reflectance	TR <sub>RX</sub>		- 12	dB	
LOS Assert	LOS <sub>A</sub>	- 30		dBm	
LOS De-Assert	LOS <sub>D</sub>		- 17	dBm	
LOS Hysteresis	LOS <sub>H</sub>	0.5		dB	

### Notes:

1. Average, Informative
2. Measured with worst ER: BER<10<sup>-12</sup> 2<sup>31</sup>-1 PRBS
3. IEEE 802.3ae

### Electrical Characteristics – Transmitter

VCC=3.14V to 3.46V, T<sub>C</sub>=0°C to 70°C

Parameter	Symbol	Min	Typ	Max	Unit	Remarks
Input differential impedance	R <sub>IN</sub>		100		Ω	
Differential data input swing	V <sub>IN_PP</sub>	180		700	mV	
Transmit disable voltage	V <sub>D</sub>	2		V <sub>CC</sub>	V	
Transmit enable voltage	V <sub>EN</sub>	V <sub>EE</sub>		V <sub>EE</sub> +0.8	V	

### Electrical Characteristics – Receiver

VCC=3.14V to 3.46V, T<sub>C</sub>=0°C to 70°C

Parameter	Symbol	Min	Typ	Max	Unit	Remarks
Differential data output swing	V <sub>OUT_PP</sub>	300		850	mV	
Data output rise time (20%-80%)	T <sub>R</sub>	30			ps	
Data output fall time (20%-80%)	T <sub>F</sub>	30			ps	
LOS Fault	V <sub>LOS_Fault</sub>	2		V <sub>CC_HOST</sub>	V	
LOS Normal	V <sub>LOS_Normal</sub>	V <sub>EE</sub>		V <sub>EE</sub> +0.5	V	

### Digital Diagnostic Functions

SFP10-BIDI-T1270/R1330-20KM supports the 2-wire serial communication protocol as defined in the SFF-8472. Digital diagnostic information is accessible over the 2-wire interface at the address 0xA2. Digital diagnostics for SFP10-BIDI-T1270/R1330-20KM are internally calibrated by default. A micro controller unit inside the transceiver gathers the monitoring information and reports the status of transceiver.

**Transceiver Temperature**, internally measured, represented as a 16 bit signed twos complement value in increments of 1/256 degrees Celsius, Temperature accuracy is better than ±3 degrees Celsius over specified operating temperature and voltage.

**Transceiver Supply Power**, internally measured, represented as a 16 bit unsigned integer with the voltage defined as the full 16 bit value (0 – 65535) with LSB equal to 100 μVolt, yielding a total range of 0 to +6.55 Volts.

**Transceiver TX bias current**, internally measured, represented as a 16 bit unsigned integer with the current defined as the full 16 bit value (0 – 65535) with LSB equal to 2  $\mu$ A, yielding a total range of 0 to 131mA. Accuracy is better than  $\pm 10\%$  over specified operating temperature and voltage.

**Transceiver TX output power**, internally measured, represented as a 16 bit unsigned integer with the power defined as the full 16 bit value (0 – 65535) with LSB equal to 0.1  $\mu$ W. Data is assumed to be based on measurement of laser monitor photodiode current. Accuracy is better than  $\pm 3$ dB over specified temperature and voltage. Data is not valid when the transmitter is disabled.

**Transceiver RX received optical power**, internally measured, represented as a 16 bit unsigned integer with the power defined as the full 16 bit 35 value (0 – 65535) with LSB equal to 0.1  $\mu$ W. Accuracy is better than  $\pm 3$ dB over specified temperature and voltage.

### Block Diagram of Transceiver

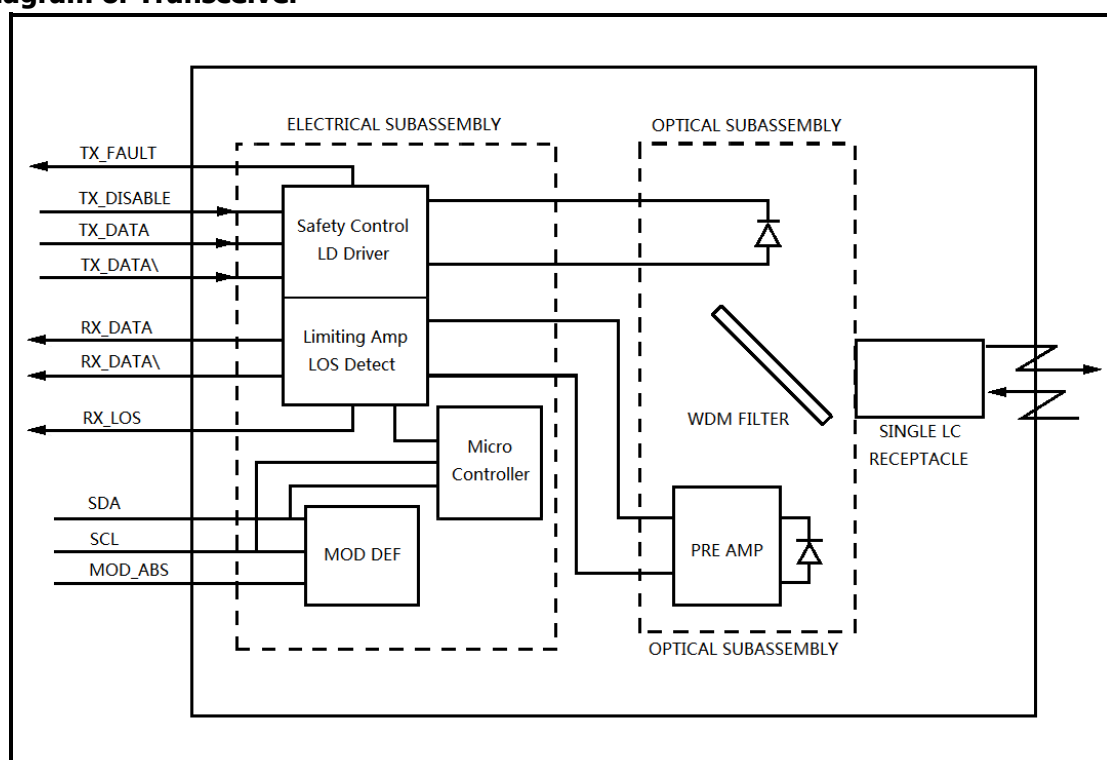

#### Transmitter Section

The Laser driver accepts differential input data and provide bias and modulation currents for driving a laser. An automatic power-control (APC) feedback loop is incorporated to maintain a constant average optical power. 1270 DFB in an eye safe optical subassembly (OSA) mates to the fiber cable.

#### TX\_DISABLE

The TX\_DISABLE signal is high (TTL logic "1") to turn off the laser output. The laser will turn on within 1ms when TX\_DISABLE is low (TTL logic "0").

#### TX\_FAULT

When the TX\_FAULT signal is high, output indicates a laser fault of some kind. Low indicates normal operation.

**Receiver Section**

The receiver utilizes a PIN detector integrated with a trans-impedance preamplifier in an OSA. This OSA is connected to a Limiting Amplifier which providing post-amplification quantization, and optical signal detection. The limiting Amplifier is AC-coupled to the trans-impedance amplifier, with internal 100Ω differential termination.

**Receive Loss (RX\_LOS)**

The RX\_LOS is high (logic "1") when there is no incoming light from the companion transceiver. This signal is normally used by the system for the diagnostic purpose. The signal is operated in TTL level.

**Controller Section**

The micro controller unit monitors the operation information of LD driver and Limiting Amplifier. And report these status to the customer.

**Dimensions**

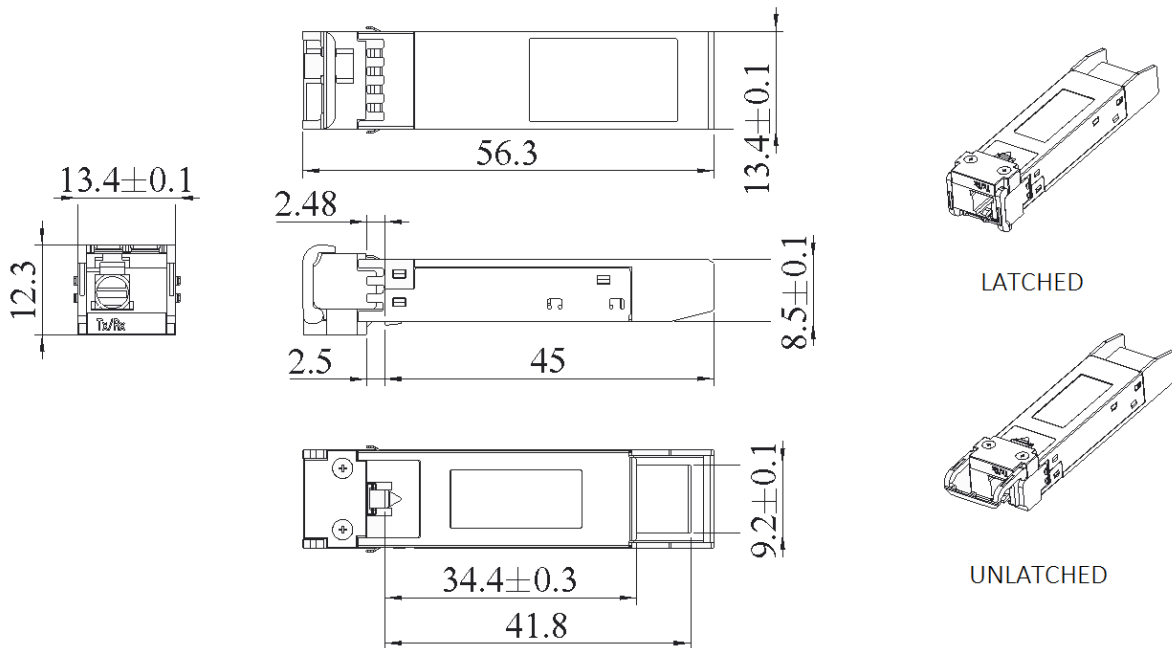

**ALL DIMENSIONS ARE ±0.2mm UNLESS OTHERWISE SPECIFIED  
UNIT: mm**

### Electrical Pad Layout

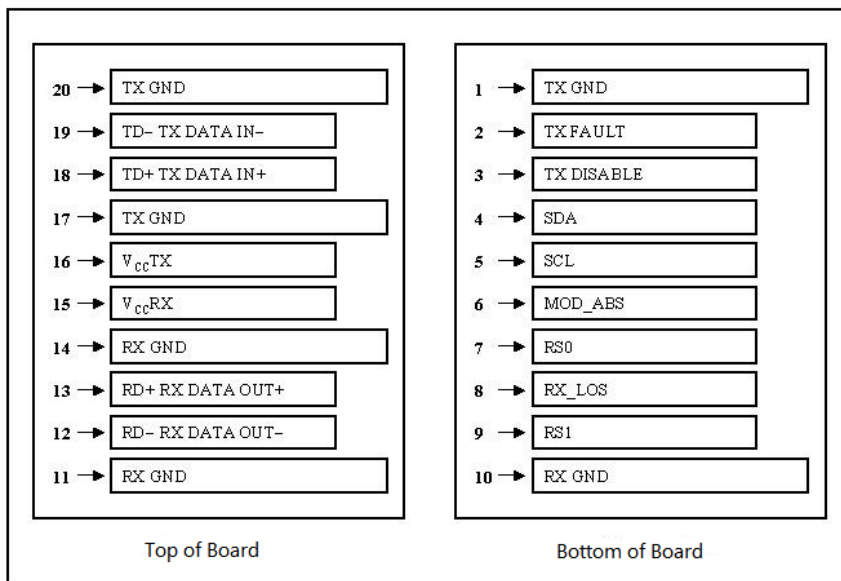
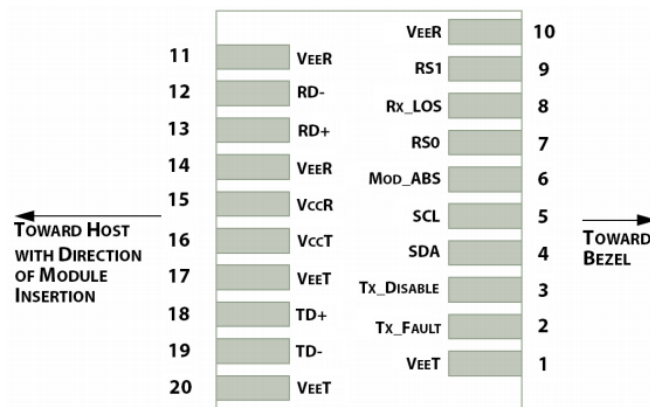

### Pin Assignment

PIN #	Symbol	Description	Remarks
1	V <sub>EET</sub>	Transmitter ground (common with receiver ground)	1
2	T <sub>FAULT</sub>	Transmitter Fault.	
3	T <sub>DIS</sub>	Transmitter Disable. Laser output disabled on high or open	2
4	SDA	2-wire Serial Interface Data Line	3

5	SCL	2-wire Serial Interface Clock Line	3
6	MOD_ABS	Module Absent. Grounded within the module	3
7	RS0	No connection required	
8	LOS	Loss of Signal indication. Logic 0 indicates normal operation	4
9	RS1	No connection required	1
10	V <sub>EER</sub>	Receiver ground (common with transmitter ground)	1
11	V <sub>EER</sub>	Receiver ground (common with transmitter ground)	1
12	RD-	Receiver Inverted DATA out. AC coupled	
13	RD+	Receiver Non-inverted DATA out. AC coupled	
14	V <sub>EER</sub>	Receiver ground (common with transmitter ground)	1
15	V <sub>CCR</sub>	Receiver power supply	
16	V <sub>CCT</sub>	Transmitter power supply	
17	V <sub>EET</sub>	Transmitter ground (common with receiver ground)	1
18	TD+	Transmitter Non-Inverted DATA in. AC coupled	
19	TD-	Transmitter Inverted DATA in. AC coupled	
20	V <sub>EET</sub>	Transmitter ground (common with receiver ground)	1

**Notes:**

1. Circuit ground is isolated from chassis ground
2. Disabled:  $T_{DIS} > 2V$  or open, Enabled:  $T_{DIS} < 0.8V$
3. Should Be pulled up with  $4.7k\Omega - 10k\Omega$  on host board to a voltage between 2V and 3.6V
4. LOS is open collector output

**References**

1. IEEE standard 802.3ae. IEEE Standard Department, 2005.
2. Enhanced 8.5 and 10 Gigabit Small Form Factor Pluggable Module "SFP+" – SFF-8431
3. Digital Diagnostics Monitoring Interface for Optical Transceivers – SFF-8472.